

TECHNICAL MANUAL

OPERATOR'S, UNIT, AND DIRECT SUPPORT  
MAINTENANCE MANUAL  
INCLUDING REPAIR PARTS AND SPECIAL TOOLS LISTS (RPSTL)  
FOR  
**CARGO BED COVER (CBC), TYPE III,  
2 1/2 T CARGO TRUCK, LMTV, AND  
LMTV TRAILER**  
NSN 5411-01-472-7852 (CAMOUFLAGE)  
NSN 5411-01-479-1932 (DESERT SAND)

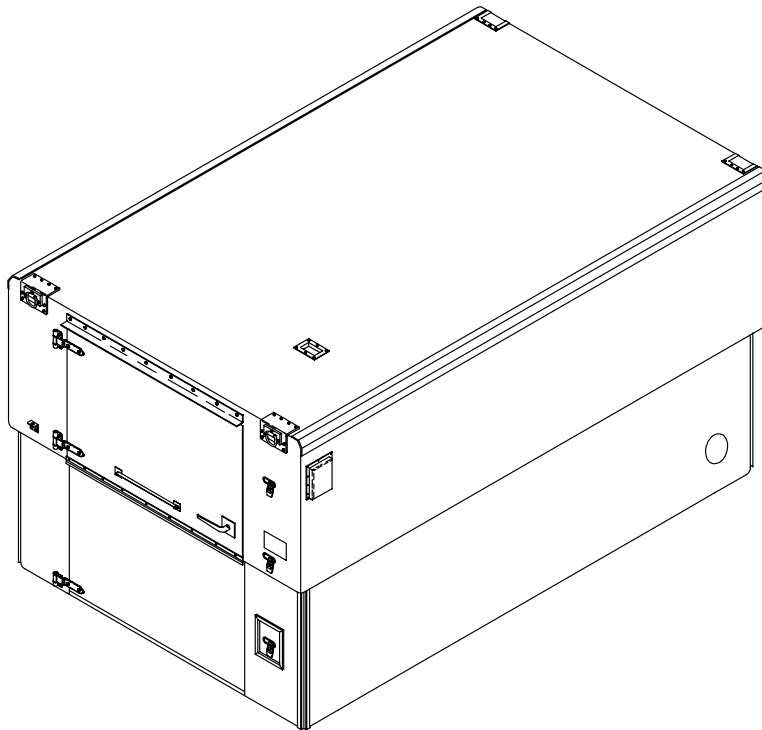

DISTRIBUTION STATEMENT A – Approved for public release; distribution is unlimited.

---

HEADQUARTERS, DEPARTMENT OF THE ARMY

30 SEPTEMBER 2002



## WARNING SUMMARY

This warning summary contains general safety warnings and hazardous materials warnings that must be understood and applied during operation and maintenance of this equipment. Failure to observe these precautions could result in serious injury or death to personnel. Also included are explanations of safety and hazardous materials icons used within the technical manual.

### EXPLANATION OF SAFETY WARNING ICONS



**HEAVY OBJECTS** - heavy object on human figure shows that heavy parts present a danger to life or limb.



**FALLING PARTS** - arrow bouncing off human shoulder and head shows that falling parts present a danger to life or limb.



**SUFFOCATION DANGER** – person with deflated lungs shows that there is a danger of an inability to breath and a potential for suffocation.



**EYE PROTECTION** - person with goggles shows that the material will injure the eyes.



**FIRE** - flame shows that a material may ignite and cause burns.

### GENERAL SAFETY WARNINGS DESCRIPTION

#### **WARNING**



Do not lift the Cargo Bed Cover (CBC) in its retracted (lowered) position.

Do not use the lift rings to lift a CBC with an installed payload greater than 1100 pounds (499 kg).

Make sure to use handling equipment rated for the equipment it will be lifting.

Do not raise the upper portion of the CBC past the warning mark on the side wall of the CBC.

#### **WARNING**



Be sure to support the lifting/locking assembly with a free hand before removing the clevis pin that secures the assembly to the roof mounted stowage block.

**WARNING**



The Personnel Door to the Cargo Bed Cover must remain open while occupied. Failure to do so may result in suffocation.

**WARNING**



Safety goggles must be worn during repair to protect eyes from flying metal chips.

**WARNING**



Methylethylketone is flammable and toxic and shall be used only in a well-ventilated area away from all sparks or open flame.

**EXPLANATION OF HAZARDOUS MATERIALS ICONS**



**CHEMICAL** - drops of liquid on hand shows that the material will cause burns or irritation to human skin or tissue.



**POISON** - skull and crossbones shows that a material is poisonous or is a danger to life.



**CHEMICAL** - drops of liquid on hand shows that the material will cause burns or irritation to human skin or tissue.

**HAZARDOUS MATERIALS DESCRIPTION**

**WARNING**



**METHYLETHYLKETONE**

Methylethylketone is flammable and toxic and shall be used only in a well-ventilated area away from all sparks or open flame. Gloves and safety goggles should be worn during use.

**WARNING**



**TWO PART EPOXY ADHESIVE**

Two part epoxy adhesive is flammable and toxic and shall be used only in a well-ventilated area away from all sparks or open flame. Gloves and safety goggles should be worn during use.

**WARNING**



**ALODINE**

Alodine is flammable and toxic and shall be used only in a well-ventilated area away from all sparks or open flame. Gloves and safety goggles should be worn during use.

**WARNING**



**TWO PART SEALANT, MIL-S-8802, TYPE II, CLASS 8**

Two part sealant is flammable and toxic and shall be used only in a well-ventilated area away from all sparks or open flame. Gloves and safety goggles should be worn during use.



TM 10-5411-233-13&P

CHANGE  
NO. 1

HEADQUARTERS, DEPARTMENT OF THE ARMY  
WASHINGTON, DC, 30 SEPTEMBER 2005

TECHNICAL MANUAL

OPERATOR'S, UNIT AND DIRECT SUPPORT MAINTENANCE MANUAL  
INCLUDING REPAIR PARTS AND SPECIAL TOOLS LIST (RPSTL)  
FOR

CARGO BED COVER (CBC), TYPE III, 2 ½ T CARGO TRUCK,  
LMTV AND LMTV TRAILER

NSN: 5411-01-472-7852 (CAMOUFLAGE)  
NSN: 5411-01-479-1932 (DESERT SAND)

**DISTRIBUTION STATEMENT A:** - Approved for public release; distribution is unlimited.

TM 10-5411-233-13&P, 30 September 2002, is updated as follows:

1. File this sheet in front of the manual for reference.
2. This change implements Army Maintenance Transformation and changes the Maintenance Allocation Chart (MAC) to support Field and Sustainment Maintenance.
3. New or updated change information is indicated by a vertical bar in the outer margin of the page.
4. Remove old pages and insert new pages as indicated below:

**Remove Pages**

A/(B blank)  
Sample 2028/Envelope  
DA 2028/Envelope  
DA 2028/Envelope

**Insert Pages**

A/(B blank)  
Sample 2028 Front/Back  
DA 2028 Front/Back  
DA 2028 Front/Back  
DA 2028 Front/Back

5. Replace the following work packages with their revised version:

<b><u>Work Package Number</u></b>	<b><u>Work Package Number</u></b>	<b><u>Work Package Number</u></b>	<b><u>Work Package Number</u></b>
WP 0041 00			

ARMY TM 10-5411-233-13&P  
C1

By Order of the Secretary of the Army:

PETER J. SCHOOMAKER  
General, United States Army  
*Chief of Staff*

Official:

  
SANDRA R. RILEY  
*Administrative Assistant to the  
Secretary of the Army*  
0523006

**Distribution:** To be distributed in accordance with initial distribution number (IDN) 256681 requirements for TM 10-5411-233-13&P.



**INSERT LATEST UPDATED PAGES/WORK PACKAGES. DESTROY SUPERSEDED DATA.**

**LIST OF EFFECTIVE PAGES/WORK PACKAGES**

**NOTE:** The portion of text affected by the update is indicated by a vertical line in the outer margins of the page. Updates to illustrations are indicated by miniature pointing hands or vertical lines in the outer margins of the page in the area of the illustration changes. Zero in the "Change No." column indicates an original page or work package.

Dates of issue for original and changed pages / work packages are:

Original      30 September 2002  
 Change 1     30 September 2005

**TOTAL NUMBER OF PAGES FOR FRONT AND REAR MATTER IS 28 AND TOTAL NUMBER OF WORK PACKAGES IS 55, CONSISTING OF THE FOLLOWING:**

<b>Page/WP No.</b>	<b>Change No.</b>	<b>Page/WP No.</b>	<b>Change No.</b>
Front Cover	0	WP 0025 00 (2 pgs)	0
a – c/(d Blank)	0	WP 0026 00 (8 pgs)	0
i – iii/(iv Blank)	0	WP 0027 00 (2 pgs)	0
v/(vi Blank)	0	WP 0028 00 (2 pgs)	0
WP 0001 00 (6 pgs)	0	WP 0029 00 (2 pgs)	0
Chp 1 title page	0	WP 0030 00 (2 pgs)	0
WP 0002 00 (4 pgs)	0	WP 0031 00 (2 pgs)	0
WP 0003 00 (4 pgs)	0	WP 0032 00 (4 pgs)	0
Chp 2 title page	0	WP 0033 00 (2 pgs)	0
WP 0004 00 (8 pgs)	0	WP 0034 00 (2 pgs)	0
WP 0005 00 (34 pgs)	0	WP 0035 00 (4 pgs)	0
WP 0006 00 (2 pgs)	0	WP 0036 00 (4 pgs)	0
WP 0007 00 (2 pgs)	0	WP 0037 00 (4 pgs)	0
Chp 3 title page	0	WP 0038 00 (22 pgs)	0
WP 0008 00 (2 pgs)	0	WP 0039 00 (2 pgs)	0
WP 0009 00 (4 pgs)	0	Chp 6 title page	0
Chp 4 title page	0	WP 0040 00 (2 pgs)	0
WP 0010 00 (2 pgs)	0	WP 0041 00 (8 pgs)	1
WP 0011 00 (2 pgs)	0	WP 0042 00 (8 pgs)	0
WP 0012 00 (8 pgs)	0	WP 0043 00 (6 pgs)	0
Chp 5 title page	0	WP 0044 00 (6 pgs)	0
WP 0013 00 (12 pgs)	0	WP 0045 00 (4 pgs)	0
WP 0014 00 (22 pgs)	0	WP 0046 00 (4 pgs)	0
WP 0015 00 (18 pgs)	0	WP 0047 00 (4 pgs)	0
WP 0016 00 (14 pgs)	0	WP 0048 00 (4 pgs)	0
WP 0017 00 (4 pgs)	0	WP 0049 00 (4 pgs)	0
WP 0018 00 (6 pgs)	0	WP 0050 00 (4 pgs)	0
WP 0019 00 (4 pgs)	0	WP 0051 00 (2 pgs)	0
WP 0020 00 (4 pgs)	0	WP 0052 00 (2 pgs)	0
WP 0021 00 (4 pgs)	0	WP 0053 00 (4 pgs)	0
WP 0022 00 (6 pgs)	0	WP 0054 00 (2 pgs)	0
WP 0023 00 (6 pgs)	0	WP 0055 00 (2 pgs)	0
WP 0024 00 (4 pgs)	0	Index -1 – Index -3/(4 Blank)	0
		Back Cover	0



HEADQUARTERS,  
DEPARTMENT OF THE ARMY  
WASHINGTON, D.C., 30 SEPTEMBER 2002

TECHNICAL MANUAL

OPERATOR’S, UNIT, AND DIRECT SUPPORT MAINTENANCE MANUAL  
INCLUDING REPAIR PARTS AND SPECIAL TOOLS LIST (RPSTL)

CARGO BED COVER (CBC), TYPE III,  
2 1/2 T CARGO TRUCK, LMTV, AND LMTV TRAILER  
NSN 5411-01-472-7852 (CAMOUFLAGE)  
NSN 5411-01-479-1932 (DESERT SAND)

REPORTING ERRORS AND RECOMMENDING IMPROVEMENTS

You can help improve this manual. If you find any mistakes or if you know of a way to improve the procedures, please let us know. Mail your letter together with DA Form 2028 (Recommended Changes to Publications and Blank Forms), located in the back of this manual, directly to: Commander, U.S. Army Soldier and Biological Chemical Command, ATTN: AMSSB-RIM-L(N), Kansas Street, Natick, MA 01760-5052. You may also send in your recommended changes via electronic mail directly to amssb riml@natick.army.mil. A reply will be furnished to you. Instructions for sending an electronic 2028 may be found at the back of this manual immediately preceding the hard copy 2028.

DISTRIBUTION STATEMENT A – Approved for public release. Distribution is unlimited.

TABLE OF CONTENTS

WP Sequence No.

WARNING SUMMARY

HOW TO USE THIS MANUAL

General Information ..... 0001 00

CHAPTER 1 - DESCRIPTION AND THEORY OF OPERATION

Location And Description Of Major Components ..... 0002 00

Theory Of Operation..... 0003 00

CHAPTER 2 - OPERATOR INSTRUCTIONS

Controls, Indicators, Labels And Instruction Plates..... 0004 00

Operation Under Usual Conditions..... 0005 00

Operation Under Unusual Conditions..... 0006 00

Operator Lubrication And Service Parts Information..... 0007 00

**TABLE OF CONTENTS - continued**

	<u>WP Sequence No.</u>
<b>CHAPTER 3 – TROUBLESHOOTING PROCEDURES</b>	
Operator Malfunction Symptom Index.....	0008 00
Troubleshooting Procedures .....	0009 00
<hr/>	
<b>CHAPTER 4 – OPERATOR MAINTENANCE INSTRUCTIONS</b>	
Service Upon Receipt .....	0010 00
Operator Maintenance Introduction.....	0011 00
Preventive Maintenance Checks And Services (PMCS).....	0012 00
<hr/>	
<b>CHAPTER 5 – UNIT MAINTENANCE INSTRUCTIONS</b>	
Installation Of Mounting Kit For M35A2, 2 1/2 T Cargo Truck .....	0013 00
Installation Of Mounting Kit For M1078, 2 1/2 T LMTV .....	0014 00
Installation Of Mounting Kit For M1082, 2 1/2 T LMTV Trailer.....	0015 00
Unit Maintenance – Ladder Installation .....	0016 00
Repair Of Small Dent Or Depression.....	0017 00
Repair Of Depression Or Small Puncture .....	0018 00
Repair Of Puncture With Minimal Damage .....	0019 00
Repair Of Puncture With Core Fracture.....	0020 00
Repair Of Damage With Extended Cracks .....	0021 00
Repair Of Puncture Through One Skin And Core.....	0022 00
Repair Of Puncture Through Both Skins And Core.....	0023 00
Blind Rivet Removal And Installation .....	0024 00
Caulking Repaired Sections.....	0025 00
Threaded Insert Repair .....	0026 00
Roof Access Handhold.....	0027 00
Upper Roof Access Step .....	0028 00
Lifting Rings .....	0029 00
Air Filter .....	0030 00
Lifting Locking Assembly .....	0031 00
Winch Assembly .....	0032 00
Lower Roof Access Step .....	0033 00
Carrier Mounting Angles .....	0034 00
Personnel Door Weatherseal .....	0035 00
Upper And Lower Personnel Door .....	0036 00
Mounting Plate Rivnut Repair .....	0037 00
Winch Cable Assembly .....	0038 00
Painting And Refinishing .....	0039 00
<hr/>	
<b>CHAPTER 6- SUPPORTING INFORMATION</b>	
References.....	0040 00
Maintenance Allocation Chart .....	0041 00
Introduction To Repair Parts And Special Tools List.....	0042 00
Repair Parts And Special Tools List – Upper Extendable Section .....	0043 00
Repair Parts And Special Tools List – Lower Stationary Section .....	0044 00

**TABLE OF CONTENTS - continued**

WP Sequence No.

Repair Parts And Special Tools List – Personnel Door.....	0045 00
Repair Parts And Special Tools List – Mounting Kit M35A2, 2 1/2 T Cargo Truck .....	0046 00
Repair Parts And Special Tools List – Mounting Kit M1078, 2 1/2 T LMTV .....	0047 00
Repair Parts And Special Tools List - Vehicle Mounting Kit M1082, 2 1/2 T LMTV Trailer...	0048 00
Repair Parts And Special Tools List – Entry Ladder Kit .....	0049 00
Repair Parts And Special Tools List - Bulk Materials List .....	0050 00
National Stock Number Index .....	0051 00
Part Number Index .....	0052 00
Components Of End Item (COEI) List & Basic Issue Items (BII) List .....	0053 00
Additional Authorization List .....	0054 00
Expendable And Durable Items List.....	0055 00
<hr/>	
ALPHABETICAL INDEX.....	INDEX 1
<hr/>	



## TM 10-5411-233-13&P

### HOW TO USE THIS MANUAL

This Manual contains General Information, Operating Instructions, Operator Preventive Maintenance Checks and Services (PCMS), Troubleshooting, and Maintenance/Repair instructions for the Cargo Bed Cover (CBC), Type III 2 1/2 T Cargo Truck, LMTV and LMTV Trailer.

Chapter 1 contains introductory information on the CBC and its associated equipment as well as a Theory of Operation. Chapter 2 includes operating instructions under usual and unusual conditions. Chapter 3 contents include operator troubleshooting. Chapter 4 contains Operator Maintenance instructions including PMCS procedures. Chapter 5 contains Unit Maintenance instructions. Chapter 6 contains Direct Support Maintenance instructions. Chapter 7 contains references and other supporting information. Chapter 7 also includes the Repair Parts and Special Tools List (RPSTL) which identifies those parts or tools which are unique to the operation and maintenance of this equipment.

**Manual Organization and Page Numbering System.** The Manual is divided into seven major chapters that detail the topics mentioned above. Within each chapter are work packages covering a wide range of topics. Each work package is numbered sequentially starting at page 1. The work package has its own page numbering scheme and is independent of the page numbering used by other work packages. Each page of a work package has a page number of the form XXXX YY-ZZ where XXXX is the work package number (e.g. 0010 is work package 10) and YY is the revision number for that work package and ZZ represents the number of the page within that work package. A page number such as 0010 00-1/(2 blank) means that page 1 contains information but page 2 of that work package has been intentionally left blank.

**Text and Illustrations.** Descriptive text and procedures are always accompanied by one or more illustrations. The text or procedure will be annotated with find numbers such as "(1)" that correspond to a specific callout on the illustration. In this technical manual, the descriptive text or procedure will always precede the illustration. Therefore, when reading a section in the manual, always look for the accompanying illustration to follow the section.

**Finding Information.** The Table of Contents permits the reader to find information in the manual quickly. The reader should start here first when looking for a specific topic. The Table of Contents lists the topics contained within each chapter and the Work Package Sequence Number where it can be found.

Example: If the reader were looking for instructions on "Preventive Maintenance Checks and Services", which is an Operator Maintenance topic, the Table of Contents indicates that Operator Maintenance information can be found in Chapter 4. Scanning down the listings for Chapter 4, "Preventive Maintenance Checks and Services" information can be found in WP 0012 00 (i.e. Work Package 12).

An Alphabetical Index can be found at the back of the manual, and lists specific topics with the corresponding work package.





**CARGO BED COVER (CBC), TYPE III, 2 1/2 T CARGO TRUCK, LMTV, AND LMTV TRAILER 0001 00  
GENERAL INFORMATION**

**SCOPE**

This Technical Manual contains instructions for the operation as well as installation, and preventive/ corrective maintenance for the Cargo Bed Cover (CBC), Type III, M35A2, 2 1/2 T Cargo Truck, M1078, LMTV, and M1082, LMTV Trailer (1) as well as its installation mounting plates (2,3) used when the CBC is installed on the M1078, 2 1/2 T Lightweight Medium Tactical Vehicle (LMTV) or M1082, 2 1/2 T LMTV Trailer.

**Type of Manual.** Operator's, Organizational, and Direct Support Maintenance Manual (including Repair Parts and Special Tools Lists).

**Equipment Nomenclature and National Stock Number.** Cargo Bed Cover, 2 1/2T Cargo Truck (CBC), NSN 5411-01-472-7852 (Camouflage), NSN 5411-01-479-1932 (Desert Sand).

**Purpose of Equipment.** The Cargo Bed Cover (CBC), Type III, 2 1/2 T Cargo Truck, LMTV, And LMTV Trailer is a hard shell enclosure designed to provide a secure and weather tight enclosure for equipment and personnel and is offered in either Camouflage or Desert Sand color configurations. The CBC features a built-in mechanism to raise or lower the upper section which can be accomplished by a team of two in 20 minutes.

**Points of Reference.** The CBC is mounted to the bed of the vehicle so that the rear door of the CBC is located at the tailgate of the vehicle. The front of the CBC is the end opposite the door and mounts on the vehicle bed so that it is directly behind the cab of the vehicle. In this technical manual, the term "driver side" will refer to the left side of the CBC as the operator faces the rear door. The term "passenger side" will refer to the right side of the CBC as the operator faces the rear door. It is assumed that the vehicle is equipped with a steering wheel on the left side as the driver is sitting in the vehicle.

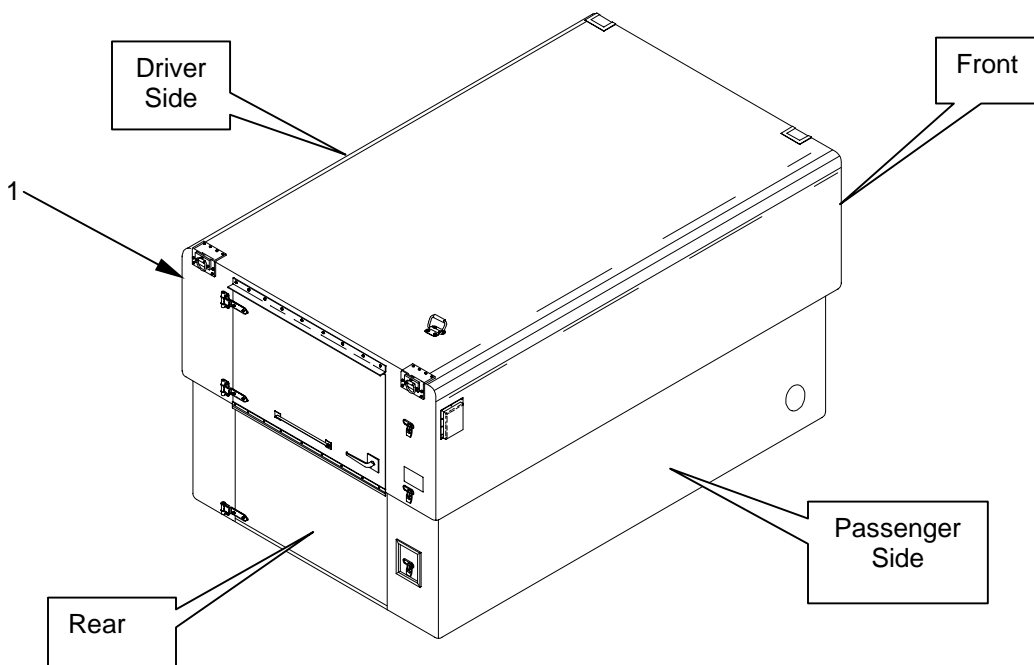

**CARGO BED COVER (CBC), TYPE III, 2 1/2 T CARGO TRUCK, LMTV, AND LMTV TRAILER 0001 00  
GENERAL INFORMATION**

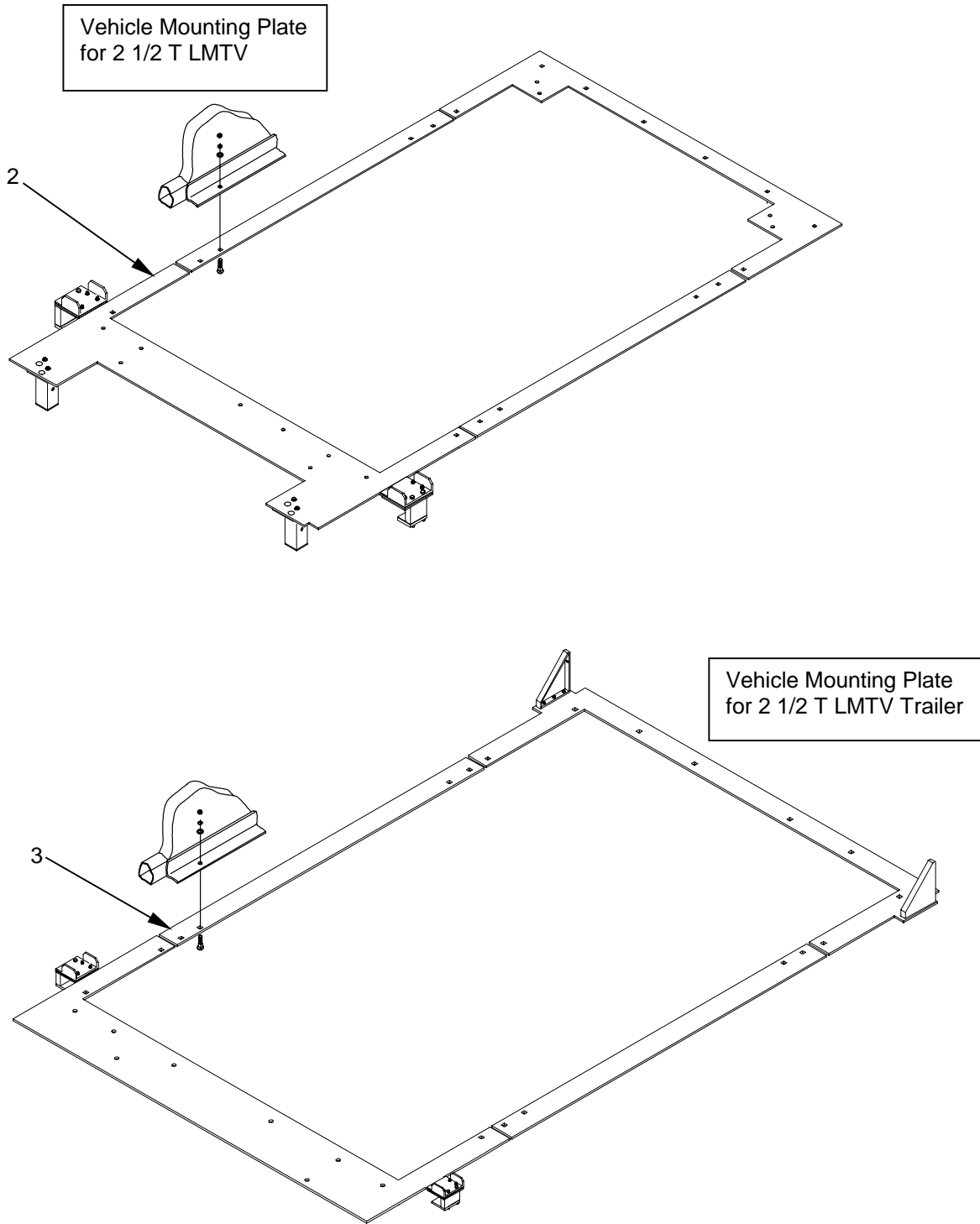

---

**CARGO BED COVER (CBC), TYPE III, 2 1/2 T CARGO TRUCK, LMTV, AND LMTV TRAILER 0001 00  
GENERAL INFORMATION**

---

**MAINTENANCE FORMS RECORDS AND REPORTS.**

Department of the Army forms and procedures used for equipment maintenance will be those prescribed by DA PAM 738-750, Functional Users Manual for The Army Maintenance Management System (TAMMS) (Maintenance Management Update).

**REPORTING EQUIPMENT IMPROVEMENT RECOMMENDATIONS (EIRs).**

If your CBC needs improvement, let us know. Send us an EIR. You, the user, are the only one who can tell us what you don't like about your equipment. Let us know why you don't like the design or performance. Put it on an SF368, Product Quality Deficiency Report . Mail it to: Commander U.S. Army Soldier and Biological Chemical Command; ATTN: AMSSB-RIM-E(N), Kansas St. Natick MA 01760-5052. We will send you a reply.

**CORROSION PREVENTION AND CONTROL (CPC).**

Corrosion Prevention and Control (CPC) of Army materiel is a continuing concern. It is important that any corrosion problems with this item be reported so that the problem can be corrected and improvements can be made to prevent the problem in future items.

While corrosion is typically associated with rusting of metals, it can also include deterioration of other materials, such as rubber or plastic. Unusual cracking, softening, swelling or breaking of these materials may be a corrosion problem.

If a corrosion problem is identified, it can be reported using SF 368, Product Quality Deficiency Report. Use of key words such as "corrosion", "rust", "deterioration" or "cracking" will ensure that the information is identified as a CPC problem. This form should be submitted to the address specified in DA Pam 738-750.

**DESTRUCTION OF ARMY MATERIEL TO PREVENT ENEMY USE.**

For procedures to destroy this equipment to prevent its use by the enemy, refer to TM 750-244-3, Procedures for Destruction of Army Equipment to Prevent Enemy Use (Mobility Equipment Command).

**WARRANTY INFORMATION**

The Cargo Bed Cover (CBC), Type III, 2 1/2 T Cargo Truck, LMTV, And LMTV Trailer is warranted by Marion Composites, a division of Advanced Technical Products, Inc. for 12 months. Warranty starts on the date found on DA Form 2410 or DA Form 2408-16 in the logbook. Report all defects in material or workmanship to your supervisor who will take appropriate action.

**NOMENCLATURE CROSS-REFERENCE LIST.**

<b>Common Name</b>	<b>Official Name</b>
CBC	Cargo Bed Cover (CBC), Type III, 2 1/2 T Cargo Truck, LMTV, And LMTV Trailer
Mounting Plate	Vehicle Mounting Plate
M1078, 2 1/2 T LMTV	2 1/2 T Lightweight Medium Tactical Vehicle

**TM 10-5411-233-13&P**

**CARGO BED COVER (CBC), TYPE III, 2 1/2 T CARGO TRUCK, LMTV, AND LMTV TRAILER 0001 00  
GENERAL INFORMATION**

<b>Common Name</b>	<b>Official Name</b>
M1082, 2 1/2 T LMTV Trailer	2 1/2 T Lightweight Medium Tactical Vehicle Trailer

<b>LIST OF ABBREVIATIONS/ACRONYMS</b>			
AAL	Additional Authorization List	LMTV	Lightweight Medium Tactical Vehicle
BII	Basic Issue Item	MSDS	Material Safety Data Sheet
CAGEC	Commercial and Government Entity Code	MTOE	Modified Table of Org and Equipment
CBC	Cargo Bed Cover	NBC	Nuclear, Biological, Chemical
COEI	Component of End Item	NSN	National Stock Number
CPC	Corrosion Prevention Control	PMCS	Preventive Maintenance Checks and Services
cm	Centimeter	POL	Petroleum, Oil and Lubricant
CTA	Common Table of Allowances	RPSTL	Repair Parts and Special Tools List
°C	Degrees Celsius	RTV	Room Temperature Vulcanizing
DECON	Decontamination	T	Ton
°F	Degrees Fahrenheit	TAMMS	The Army Maintenance Management System
EIR	Equipment Improvement Recommendation	TDA	Table of Distribution and Allowances
IAW	In Accordance With	TMDE	Test, Measurement, Diagnostic Equipment
in	Inches	TOE	Table of Organization and Equipment
JTA	Joint Table of Allowances	U/M	Unit of Measure
Kg	Kilogram	UOC	Usable On Code
lbs	Pounds	WP	Work Package

**SAFETY, CARE AND HANDLING, WARNINGS, CAUTIONS AND NOTES.**

Always pay attention to Warnings, Cautions and Notes appearing throughout the manual. They will appear prior to applicable procedures. Ensure you read and understand their content to prevent serious injury to yourself and others, or damage to equipment.

**CARGO BED COVER (CBC), TYPE III, 2 1/2 T CARGO TRUCK, LMTV, AND LMTV TRAILER 0001 00  
GENERAL INFORMATION**

**EQUIPMENT CHARACTERISTICS, CAPABILITIES AND FEATURES.**

CHARACTERISTICS	CAPABILITIES AND FEATURES
<p>Upper section lowers for travel/storage</p> <p>Personnel Door operates in height extended and retracted mode. Features secondary exit panel.</p> <p>Walls constructed of lightweight, high strength sandwich panels utilizing aluminum facing sheets bonded to aluminum honeycomb core</p> <p>Carrier mounting provisions (requires specific mounting kits)</p> <p>Simple installation and removal</p> <p>Hoist fittings</p> <p>Environmental protection of cargo space</p> <p>Chemical agent resistance</p> <p>Air-transportable (internal and external) while mounted to vehicle</p> <p>Two ventilation openings</p> <p>Security for installed contents</p> <p>Roof access steps and handhold</p> <p>Power and signal ports</p> <p>Complete Blackout Capable</p> <p>External Power and Signal Entry Ports</p>	<p>Capable of internal air transport on vehicle</p> <p>Door hardware permits opening from the inside of CBC even if outside is padlocked</p> <p>Helicopter sling Rub Strips extend entire length of CBC.</p> <p>Non-skid roof surface</p> <p>Complete Blackout Capable</p> <p>External Power and Signal Entry Ports</p> <p>Capable of External Air Transport</p>



TM 10-5411-233-13&P

**CHAPTER 1**

**DESCRIPTION AND  
THEORY OF OPERATION  
FOR  
CARGO BED COVER (CBC), TYPE III,  
2 1/2 T CARGO TRUCK, LMTV, AND LMTV TRAILER**





---

**CARGO BED COVER (CBC), TYPE III, 2 1/2 T CARGO TRUCK, LMTV, AND LMTV TRAILER 0002 00**  
**LOCATION AND DESCRIPTION OF MAJOR COMPONENTS**

---

**LOCATION AND DESCRIPTION OF MAJOR COMPONENTS**

**Expandable Upper Section (1).** The expandable upper section of the Cargo Bed Cover (CBC), Type III, 2 1/2 T Cargo Truck, LMTV, And LMTV Trailer can be extended while in operational mode or can be in a height-retracted mode for air transport.

**Lower Stationary Section (2).** The lower section of the CBC remains stationary and is mounted to the cargo truck bed (or vehicle mounting plate) by means of the carrier mounting angles **(3)**.

**Carrier Mounting Angles (3).** The carrier mounting angles are mounted to the lower side walls of the CBC and have a series of holes that interface with threaded inserts in the truck bed or holes in the vehicle mounting plate. A weatherseal is installed between the CBC and the truck bed or between the CBC and the mounting plate that prevents water from entering the CBC when mounted to a vehicle.

**Lift Rings (4).** The four lift rings permit the CBC to be hoisted for transport, movement, or installation on the vehicle bed.

**Personnel Access Door (5).** The personnel access door has an upper and lower portion that mate through a tongue and groove bracket and are secured with three threaded studs with hand knobs. When in height-retracted mode, the upper portion of the personnel door acts as a secondary exit.

**Personnel Access Door Lower Section (6).** The lower section of the personnel door is removed before the upper section of the CBC is lowered. This section is stowed in "Zee" brackets mounted on the underside of the CBC roof.

**Door Latch (7).** The personnel door latch locks in place by rotating the center handle to a horizontal position. The latch can be padlocked from the outside, protecting the internal contents of the CBC. Personnel that may be inside a locked CBC can exit using the interior door handle.

**Ventilation Openings (8).** Two ventilation ports mounted on the outside of the Cargo Bed Cover provide flow-through air circulation through the CBC. Air filters help to keep dust, dirt, and other debris from entering the CBC.

**Roof Handhold (9).** The roof handhold permits access to the roof of the CBC when using the roof access steps.

**Power and Signal Ports (10).** The two power and signal ports on the front sidewall surfaces of the Cargo Bed Cover permit power and signal cables to be routed into and out of the CBC. Cover plates can be installed over the power and signal ports when not in use.

**Winch/Cable System (11).** The winch and cable system is mounted on the inside of the Cargo Bed Cover and is accessed through the personnel door. The winch mechanism permits the upper extendable section of the CBC to be raised to its operating mode.

**Helicopter Cable Rub Strip (12).** Two helicopter sling cable rub strips are mounted along the full length of the CBC roof to protect the cable and the CBC during external air transport.

**Roof Access Steps (13).** Two upper and one lower roof access steps have hinged foot pads that swing down to permit personnel to climb the rear of the CBC and gain access to the roof.

**CARGO BED COVER (CBC), TYPE III, 2 1/2 T CARGO TRUCK, LMTV, AND LMTV TRAILER 0002 00**  
**LOCATION AND DESCRIPTION OF MAJOR COMPONENTS**

**Lifting/Locking Assemblies (14).** Four upper section lifting/locking assemblies are positioned in each of the four corners of the CBC. They are used to provide rigid support of the upper section in its raised and deployed mode. They are also used as jacks to raise the upper section to its final operational position.

**Door Stop/Hold Open Device (15).** Pivoting arm on the outside of the personnel door that permits the door to be locked in an open position.

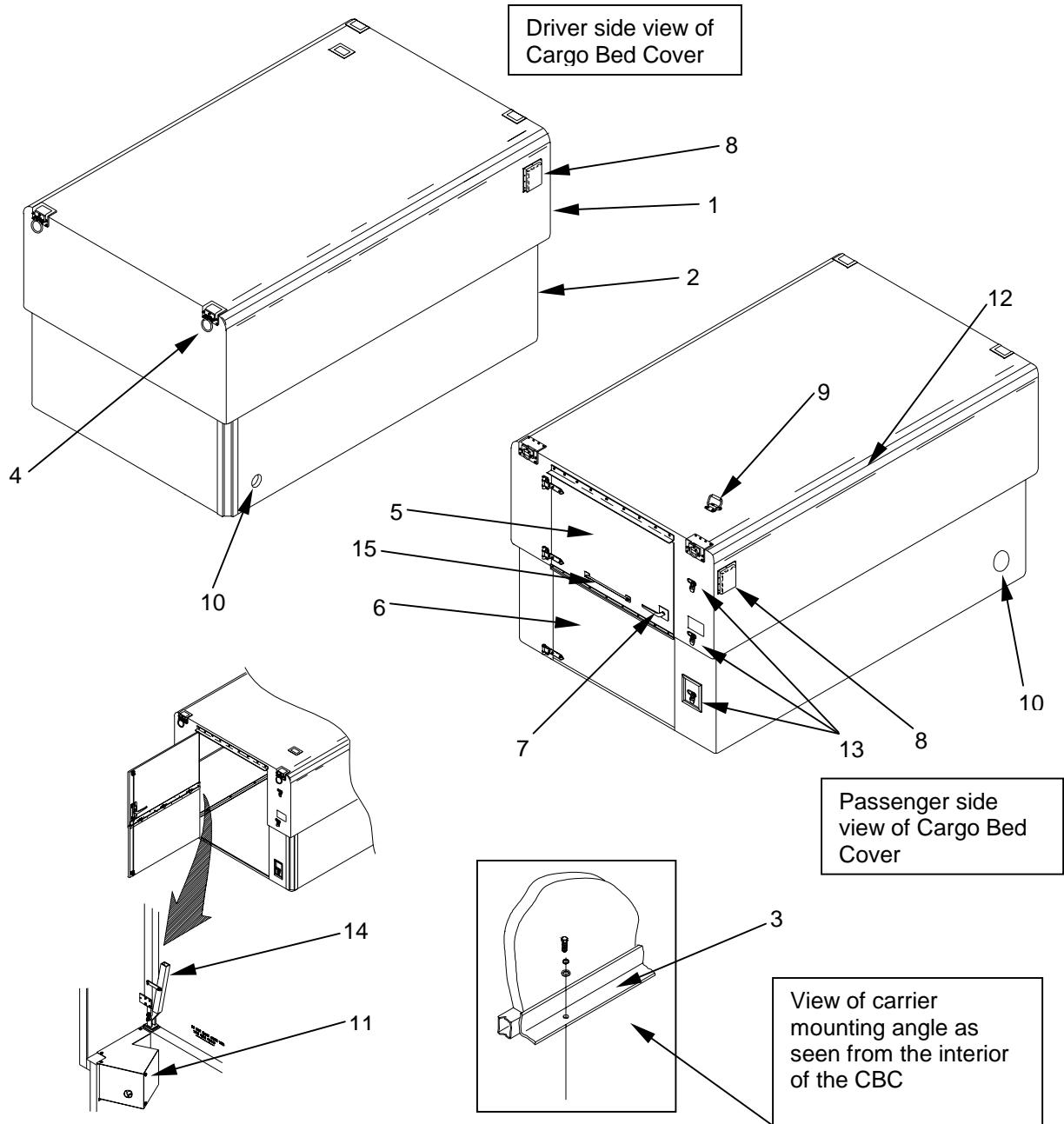

**CARGO BED COVER (CBC), TYPE III, 2 1/2 T CARGO TRUCK, LMTV, AND LMTV TRAILER 0002 00**  
**LOCATION AND DESCRIPTION OF MAJOR COMPONENTS**

**EQUIPMENT DATA**

The following technical and identification data pertains to the CBC and its installation hardware.

**Equipment Specification Data**

**Table 1-1 Equipment Data**

<b>CBC TARE WEIGHT:</b>	
M35A2, 2 1/2 T Cargo Truck Configuration (See Note 1).....	677 lbs (307 kg)
2 1/2 T LMTV and LMTV Trailer Configuration (See Note 1).....	742 lbs (336.6 kg)
<b>EXTERNAL DIMENSIONS (L X W X H):</b>	
Height-extended Mode.....	134.00 x 87.00 x 74.87 to 75.25 inches (See Note 2)
Height-retracted Mode.....	134.00 x 87.00 x 39.44 inches (See Note 2)
<b>INTERNAL DIMENSIONS (L X W X H):</b>	
Height-extended Mode.....	128.7 x 81.7 x 73.33 to 73.71 inches (See Note 2)
Height-retracted Mode.....	128.7 x 81.7 x 37.51 to 37.89 inches (See Note 2)
<b>USABLE INTERIOR VOLUME:</b>	
Height-extended Mode.....	446 cu ft (12.6 m <sup>3</sup> )
Height-retracted Mode.....	228 cu ft (6.4 m <sup>3</sup> )
Note 1: Weight of the production unit (including carrier mounting kit) is shown. The M35A2 mounting kit includes entry ladder.	
Note 2: Special mounting plates for LMTV configurations allow for use of existing mounting provisions on carrier and increase height by their thickness.	
<b>COLOR CONFIGURATIONS:</b>	
Camouflage.....	NSN 5411-01-472-7852
Desert Sand.....	NSN 5411-01-479-1932
<b>INTERNAL AIR TRANSPORT:</b>	
C-130, C-141, C-5.....	Drive-on/Back-off; Back-on/Drive-off
<b>EXTERNAL AIR TRANSPORT:</b>	
Dual point configurations of carrier-mounted CBC	
<b>STANDARD EQUIPMENT:</b>	
Carrier mounting provisions (Requires specific mounting plates)	Two ventilation openings
Hoist fittings	Personnel entry ladder
Environmental protection of cargo space	Roof access steps and handhold
Personnel access door	Power and signal entry ports
Secondary personnel exit	
<b>CONSTRUCTION:</b>	
Lightweight, high strength sandwich panels utilizing aluminum facing sheets bonded to aluminum honeycomb core	

---

**CARGO BED COVER (CBC), TYPE III, 2 1/2 T CARGO TRUCK, LMTV, AND LMTV TRAILER 0002 00**  
**LOCATION AND DESCRIPTION OF MAJOR COMPONENTS**

---

**COMMON TOOLS AND EQUIPMENT**

For authorized common tools and equipment, refer to the Modified Table of Organization and Equipment (MTOE), CTA 50-970, Expendable/Durable Items (Except: Medical, Class V, Repair Parts, and Heraldic Items), or CTA 8-100, Army Medical Department Expendable/Durable Items, as applicable to your unit.

Repair parts are listed and illustrated in the repair parts and special tools list located in work packages 0042 00 through 0052 00.

---

**CARGO BED COVER (CBC), TYPE III, 2 1/2 T CARGO TRUCK, LMTV, AND LMTV TRAILER 0003 00**  
**THEORY OF OPERATION**

---

**THEORY OF OPERATION**

**General.** The Cargo Bed Cover (CBC) is a lightweight rigid cover which can be mounted to the cargo bed area of the M35A2, 2 1/2 T Cargo Truck as well as the M1078, 2 1/2 T LMTV and M1082, 2 1/2 T LMTV Trailer and provides environmental protection and physical security for equipment carried by the vehicle.

**Operational Concept.** The Cargo Bed Cover **(1)** mounts to the bed of the M35A2, 2 1/2 T, Cargo Truck **(2)** by means of threaded inserts that are installed in the truck bed **(3)**. Carrier mounting angles and door threshold installed around the base of the lower stationary section of the CBC are used to bolt the CBC to the bed of the cargo truck.

When the CBC is to be installed on the M1078, 2 1/2 T LMTV **(4)** or M1082, 2 1/2 T LMTV Trailer **(5)**, a vehicle-specific mounting plate **(6)** must be installed on the bed of the LMTV or LMTV Trailer. The mounting plate is designed in such a way as to not require permanent modifications to the M1078, 2 1/2 T LMTV or M1082, 2 1/2 T LMTV Trailer. Once the mounting plate is installed on the bed of the M1078, 2 1/2 T LMTV or M1082, 2 1/2 T LMTV Trailer, the CBC is mounted to the vehicle mounting plate via the carrier mounting angles and door threshold.

The Cargo Bed Cover consists of an upper extendable section **(7)** and a lower stationary section **(8)**. It is the lower section that is mounted to the truck bed or vehicle mounting plate. The upper section can be lowered for air transport or extended for operational use.

The CBC is extended by means of a winch and cable system **(9)** installed inside the Cargo Bed Cover. It is locked in the extended position and supported by four lifting/locking assemblies **(15)** and cable tension.

**NOTE**

The Cargo Bed Cover should not be entered prior to raising the upper section. Access to the winch handle should be from the outside of the CBC only.

To extend the upper section of the CBC, access the winch handle through the upper portion **(10)** of the personnel door.

Once a person has accessed the winch handle through the upper portion **(10)** of the personnel door, the upper section **(7)** of the CBC is extended using the ratcheting handle **(12)** attached to the winch and cable assembly **(9)**. As the handle is turned, the upper section extends upward. The upper section is raised until the mark **(13)** stenciled on the inside wall of the upper section is visible.

When the upper section has been raised to the stenciled warning mark **(13)**, a second person removes the hairpin cotter **(14)** that secures the lifting/locking assemblies **(15)** in each corner of the CBC to the roof of the upper section. A hairpin cotter **(16)** that secures the handle **(17)** to the main body of the lifting/locking assembly **(15)** is also removed. The handle **(17)** is positioned so that it is 90° from the main body of the lifting/locking assembly.

Each lifting/locking assembly **(15)** is then swung down from its stowed position on the roof and rotated 180° counterclockwise into position over the lower section corner fitting pulley assembly **(18)** located in

---

**CARGO BED COVER (CBC), TYPE III, 2 1/2 T CARGO TRUCK, LMTV, AND LMTV TRAILER 0003 00**  
**THEORY OF OPERATION**

---

each corner of the CBC. The base **(19)** at the bottom of the lifting/locking assembly **(15)** is positioned over the corner fitting pulley assembly **(18)** on the lower section. Pins **(20)** protruding from the base **(19)** of the lifting/locking assembly **(15)** are aligned with slots located in the interlocking extrusion at the corner fitting pulley assembly **(18)**.

The handle **(17)** is then swung up and locked into position using the hairpin cotter **(16)** removed earlier.

The Cargo Bed Cover is now in its fully extended and locked position. The lower personnel door panel **(11)** is stored in an area on the inside roof surface when the CBC is in the retracted mode. The lower panel is installed when the CBC is fully extended.

Once the CBC is in its fully extended and operational position, the lower section **(11)** of the personnel door must have its hinge relocated from its stowed position before installing the lower door section **(11)** below the upper section **(10)** of the personnel door using three hand knob screws **(21)**, completing the personnel door assembly **(22)**. A door hold-open device **(23)** is provided on the outside of the personnel door to lock the door into an open position if desired.

Ventilation ports **(24)** are provided on the left and right side walls of the CBC permitting air to enter the interior.

Signal and power entry ports **(25)** are provided on the sidewalls of the CBC that permit power and signal cables to enter and/or exit from the CBC. Block out panels on the inside of the CBC are provided that allow the ports to be covered when not in use.

Three roof access steps **(26)** are located to the right of the personnel door at the rear of the CBC to provide a foothold for personnel climbing to the roof of the Cargo Bed Cover. A handhold **(27)** is installed on the top of the CBC to assist personnel in climbing onto the roof.

Lift rings **(28)** are provided on each corner of the roof to permit the CBC to be lifted into position or removed from the bed of the M35A2, 2 1/2 T Cargo Truck, M1078, 2 1/2 T LMTV, or M1082, 2 1/2 T LMTV Trailer.

**CARGO BED COVER (CBC), TYPE III, 2 1/2 T CARGO TRUCK, LMTV, AND LMTV TRAILER 0003 00**  
**THEORY OF OPERATION**

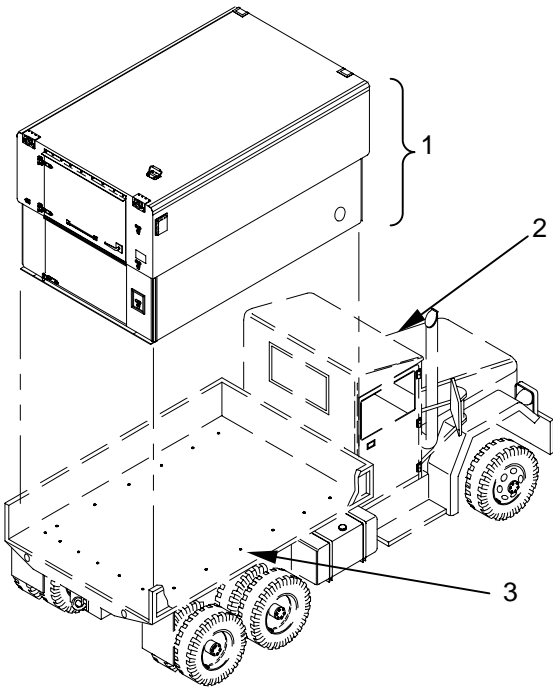

**CBC WITH M35A2, 2 1/2 T CARGO TRUCK**

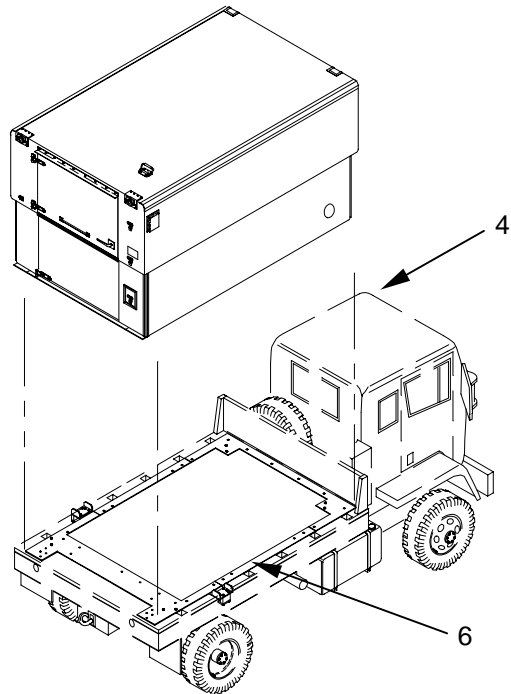

**CBC WITH M1078, 2 1/2 T LMTV**

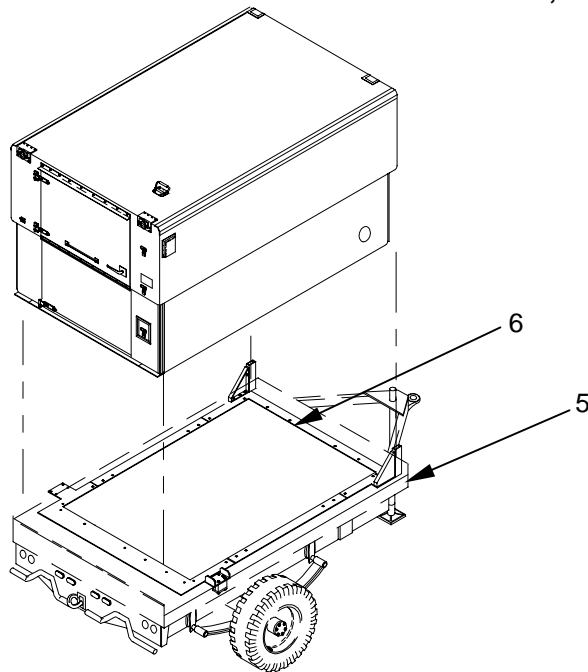

**CBC WITH M1082, 2 1/2 T LMTV Trailer**

**CARGO BED COVER (CBC), TYPE III, 2 1/2 T CARGO TRUCK, LMTV, AND LMTV TRAILER 0003 00**  
**THEORY OF OPERATION**

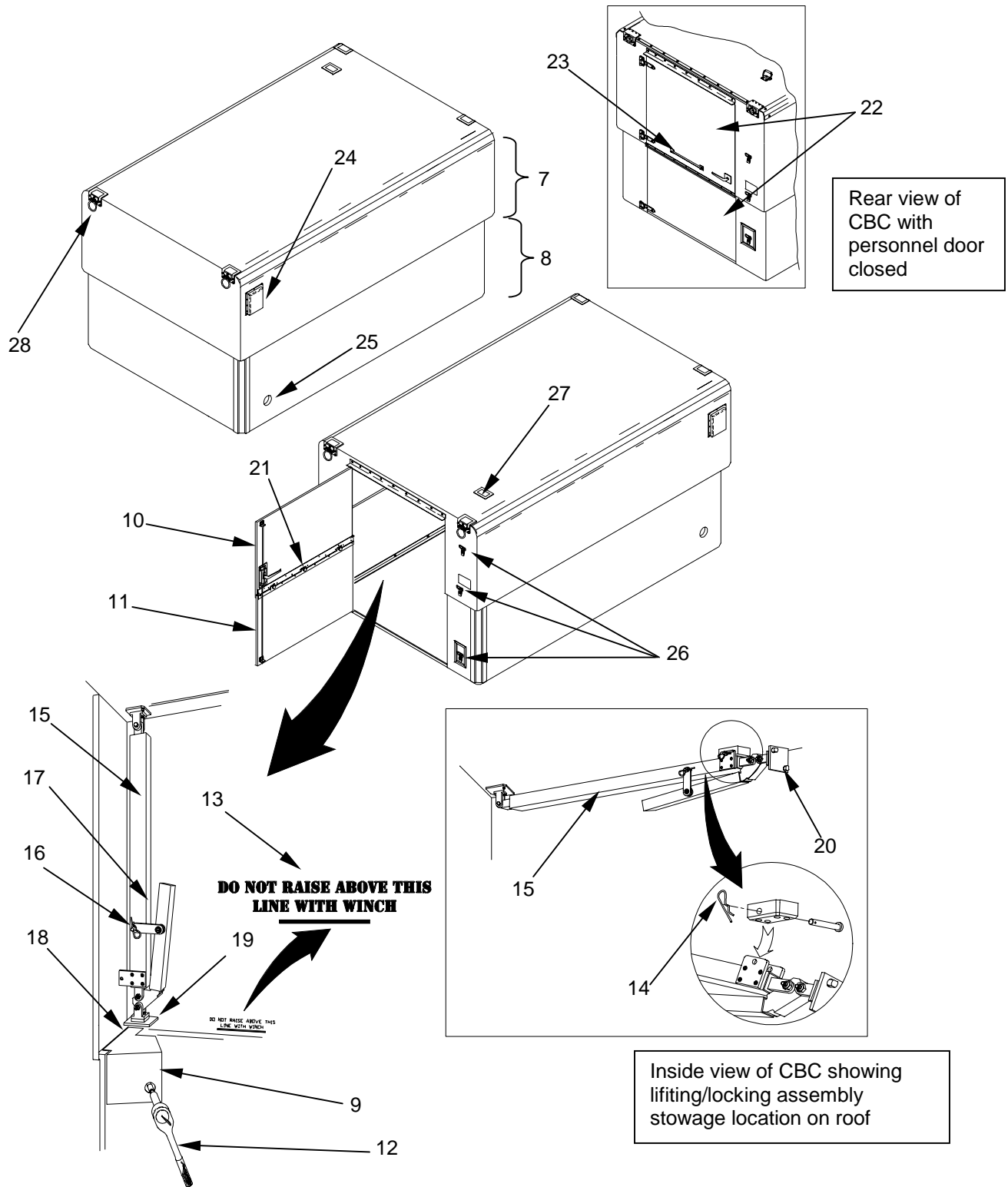



**TM 10-5411-233-13&P**

**CHAPTER 2**

**OPERATOR INSTRUCTIONS**  
**FOR**  
**CARGO BED COVER (CBC), TYPE III,**  
**2 1/2 T CARGO TRUCK, LMTV, AND LMTV TRAILER**



**CARGO BED COVER (CBC), TYPE III, 2 1/2 T CARGO TRUCK, LMTV, AND LMTV TRAILER 0004 00  
CONTROLS, INDICATORS, LABELS AND INSTRUCTION PLATES**

**GENERAL**

The following illustrations and tables show the location and function of each control on the CBC.

**PERSONNEL DOOR**

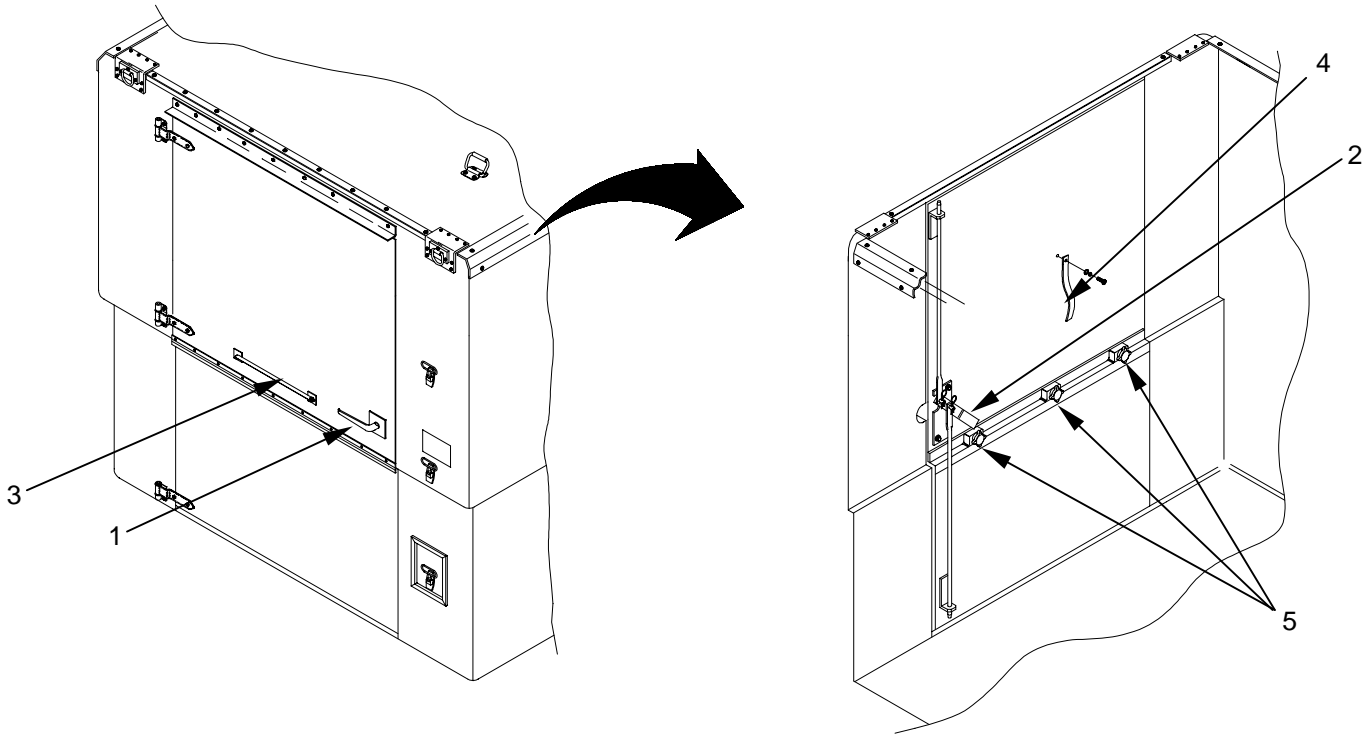

Table 1. Personnel Door Controls

KEY	CONTROL	FUNCTION
1	OUTSIDE DOOR LATCH HANDLE	Permits the personnel door to be opened or closed from the outside of the CBC.
2	INSIDE DOOR LATCH HANDLE	Permits the personnel door to be opened or closed from the inside of the CBC.
3	DOOR HOLD-OPEN DEVICE	Allows the personnel door to be locked in an open position.
4	DOOR PULL	Allows the door to be pulled closed from the vehicle bed to permit grasping the inside door latch handle.
5	HAND KNOB SCREWS	Fasten the upper section of the personnel door to the lower section personnel door.

**CARGO BED COVER (CBC), TYPE III, 2 1/2 T CARGO TRUCK, LMTV, AND LMTV TRAILER 0004 00  
CONTROLS, INDICATORS, LABELS AND INSTRUCTION PLATES**

**WINCH AND LIFTING/LOCKING ASSEMBLIES**

Table 2 describes the controls for the Winch and Lifting/Locking Assemblies.

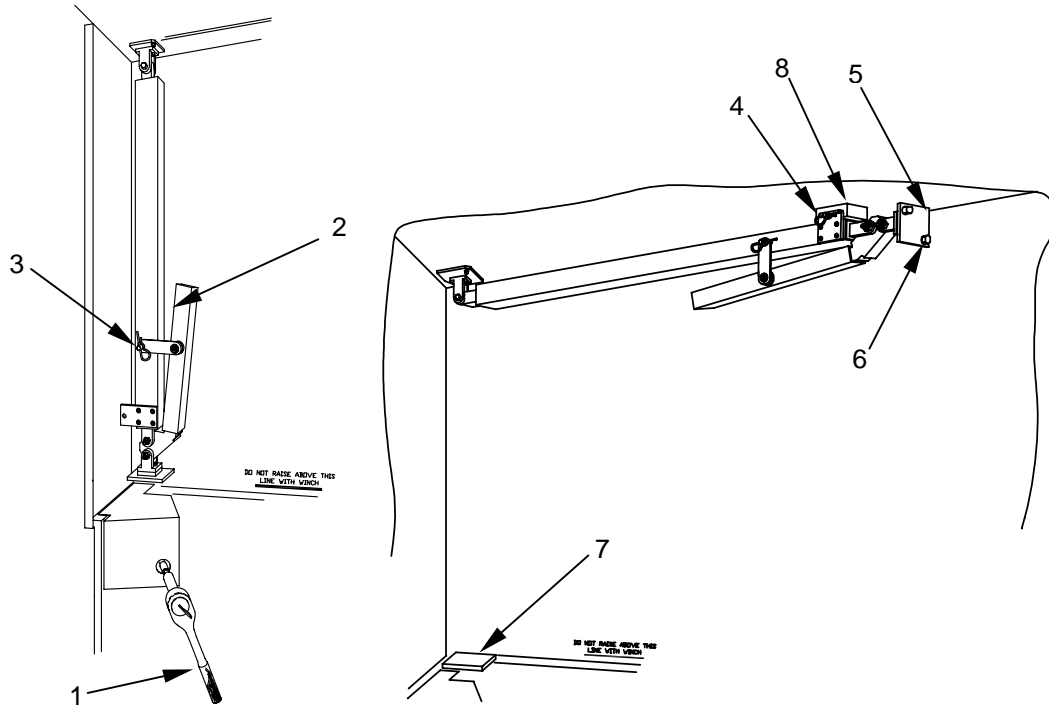

Table 2. Winch and Lifting/Locking Assemblies Controls

KEY	CONTROL	FUNCTION
1	RATCHET HANDLE	Controls winch assembly and is used to raise and lower upper expandable section of CBC
2	LIFTING/LOCKING ASSEMBLY HANDLE	Used to lock the Lifting/Locking Assembly in a vertical position
3	LIFTING/LOCKING ASSEMBLY HANDLE RELEASE HAIRPIN COTTER	Used to release the handle from the main body tube of the Lifting/Locking Assembly
4	LIFTING/LOCKING ASSEMBLY STOWAGE RELEASE HAIRPIN COTTER	Used to lock the Lifting/Locking Assembly in its stowing position on the roof of the CBC
5	LIFTING/LOCKING ASSEMBLY BASE PLATE	Engages with the Corner Fitting Pulley Assembly on the lower section to align the Lifting/Locking Assembly
6	LIFTING/LOCKING ASSEMBLY BASE PLATE ALIGNMENT PINS	Engage in the Interlock Extrusion on the lower section of the CBC to lock and align the Lifting/Locking Assembly
7	CORNER FITTING PULLEY ASSEMBLY	Engages the base of the Lifting/Locking Assembly to support and align
8	LIFTING/LOCKING ASSEMBLY ROOF STOWAGE BLOCK	Provides a docking mechanism for the Lifting/Locking Assembly when the CBC is in retracted mode

**CARGO BED COVER (CBC), TYPE III, 2 1/2 T CARGO TRUCK, LMTV, AND LMTV TRAILER 0004 00  
CONTROLS, INDICATORS, LABELS AND INSTRUCTION PLATES**

**LABELS AND INSTRUCTION PLATES**

The following labels and instruction plates are found on the Cargo Bed Cover.

**OUTSIDE VIEW OF FORWARD END WALL**

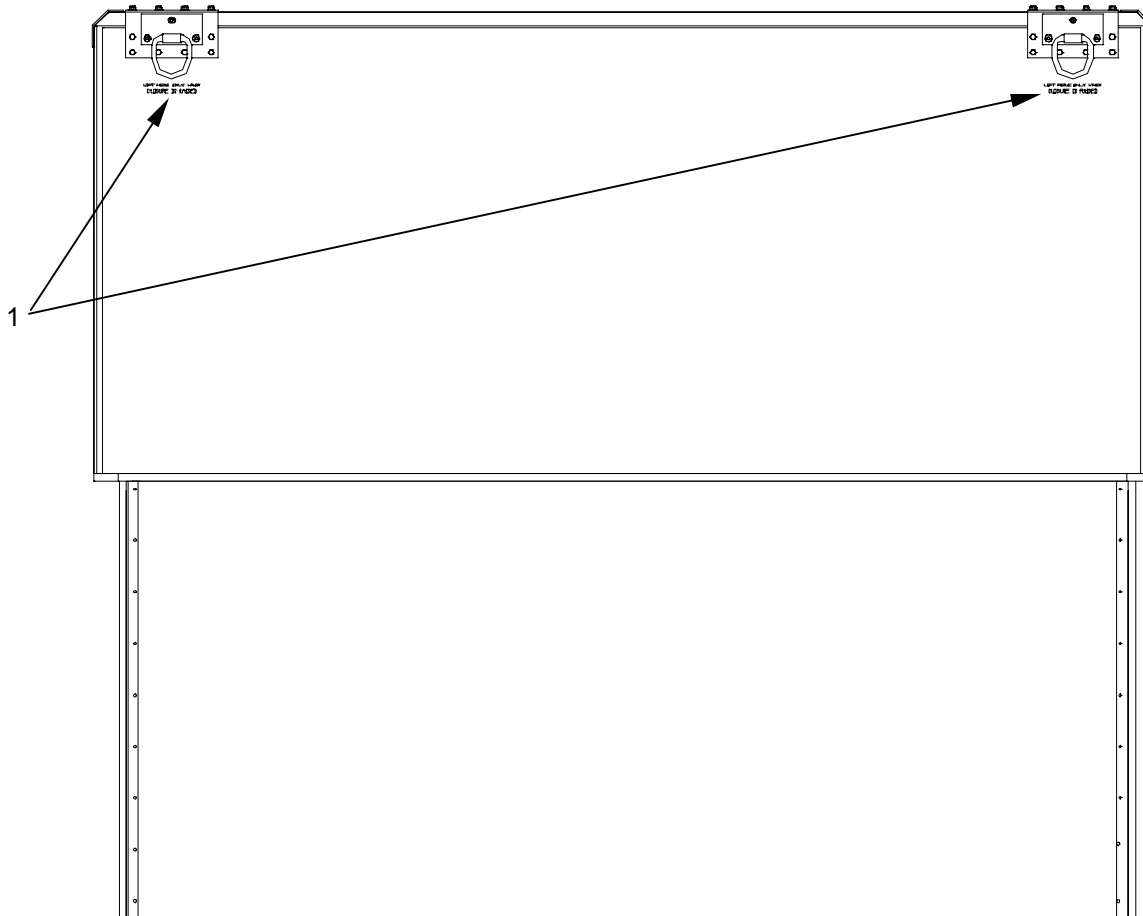

Item Number	Label/Instruction Plate
1	"Lift here only when closure is raised"

**CARGO BED COVER (CBC), TYPE III, 2 1/2 T CARGO TRUCK, LMTV, AND LMTV TRAILER 0004 00  
CONTROLS, INDICATORS, LABELS AND INSTRUCTION PLATES**

**OUTSIDE VIEW OF AFT END WALL**

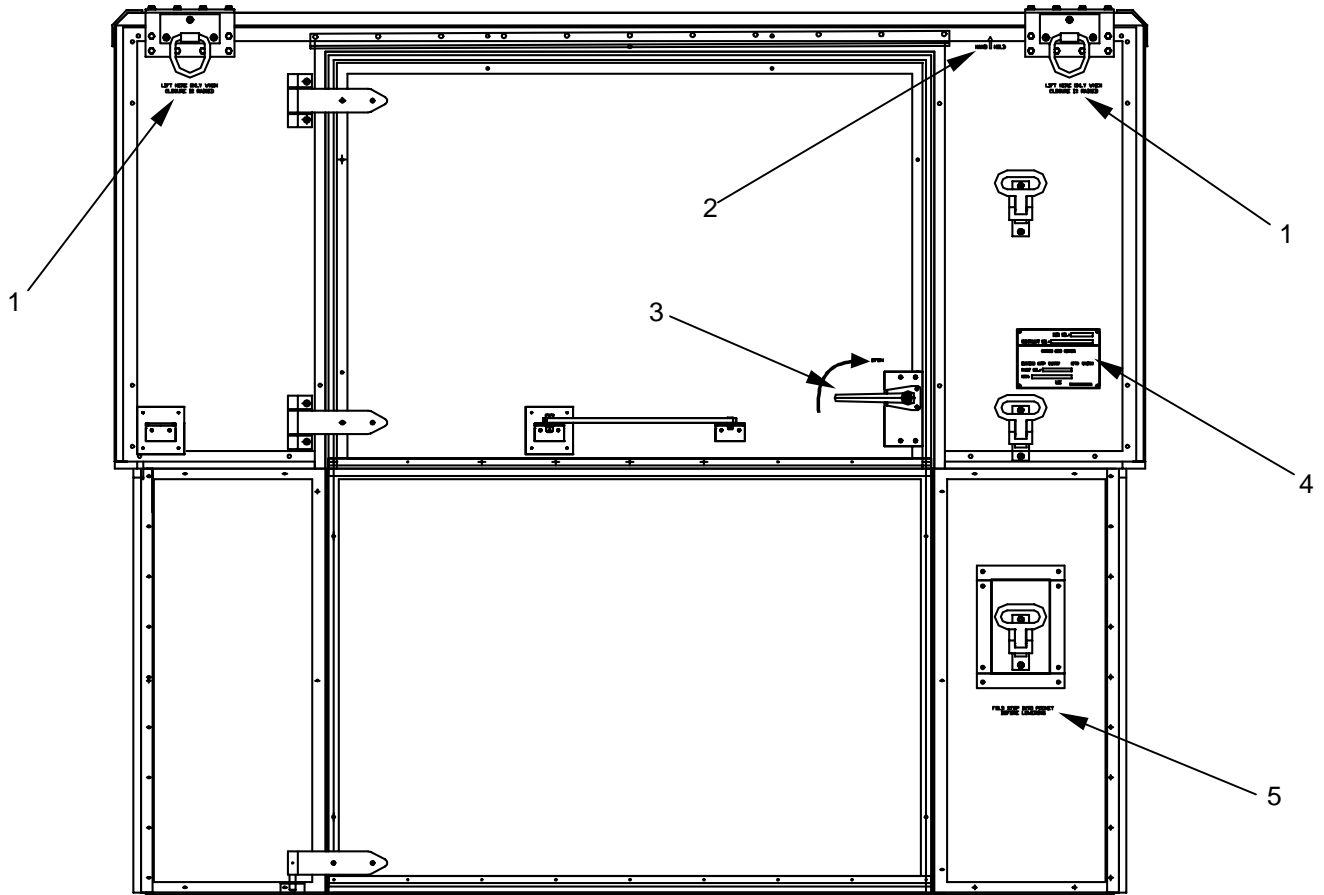

Item Number	Label/Instruction Plate
1	"Lift Here Only When Closure Is Raised"
2	"Hand Hold" (with arrow pointing to roof)
3	"Open" (with sweeping curved arrow)
4	CBC Identification Plate (see detail below)
5	"Fold Step Into Pocket" Before Lowering

**CARGO BED COVER (CBC), TYPE III, 2 1/2 T CARGO TRUCK, LMTV, AND LMTV TRAILER 0004 00  
CONTROLS, INDICATORS, LABELS AND INSTRUCTION PLATES**

**DETAIL OF IDENTIFICATION PLATE**

SER NO. : <input type="text"/>	
CONTRACT NO. : <input type="text"/>	
CARGO BED COVER	
DESIGN ACT: 81337	MFR: 04DG4
PART NO. : <input type="text"/>	
NSN: <input type="text"/>	
US	<input type="text"/>

**CARGO BED COVER (CBC), TYPE III, 2 1/2 T CARGO TRUCK, LMTV, AND LMTV TRAILER 0004 00  
CONTROLS, INDICATORS, LABELS AND INSTRUCTION PLATES**

**INSIDE VIEW OF AFT END WALL**

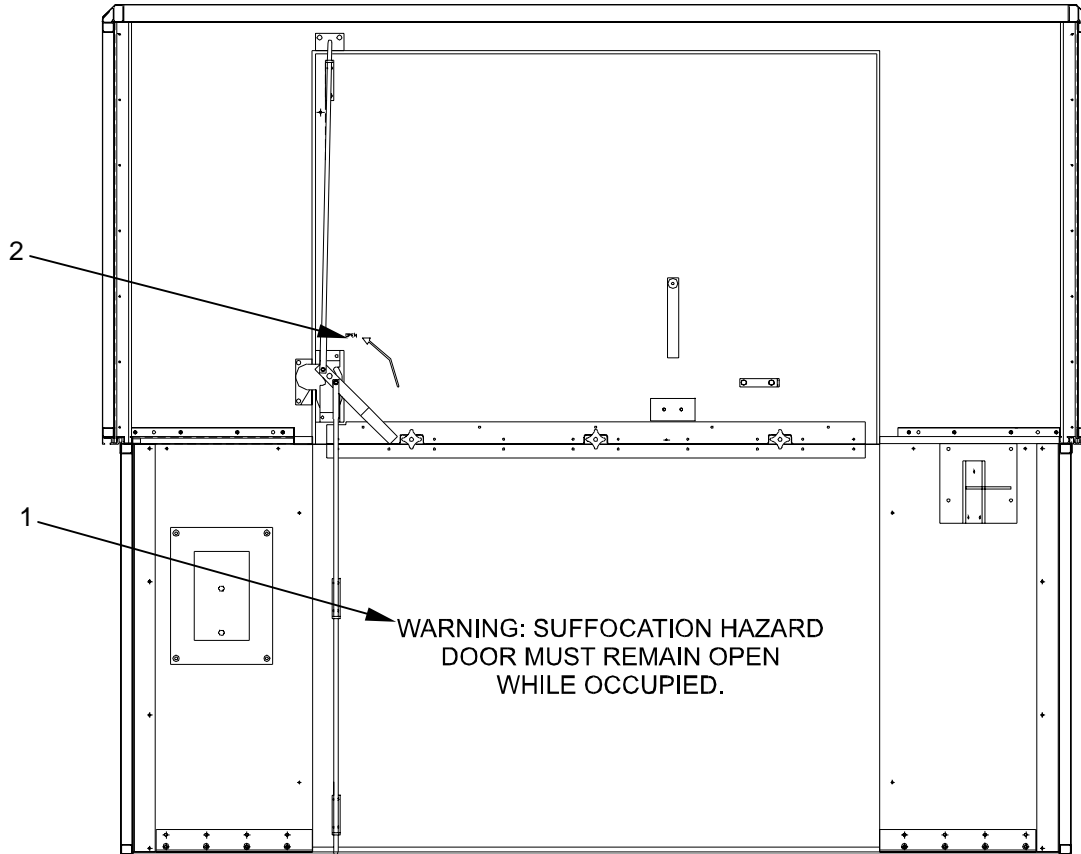

Item Number	Label/Instruction Plate
1	"Warning: Suffocation Hazard. Door Must Remain Open While Occupied."
2	"Open" (with sweeping curved arrow)



**CARGO BED COVER (CBC), TYPE III, 2 1/2 T CARGO TRUCK, LMTV, AND LMTV TRAILER 0004 00  
CONTROLS, INDICATORS, LABELS AND INSTRUCTION PLATES**

**INSIDE VIEW OF SIDE WALL (DRIVER SIDE)**

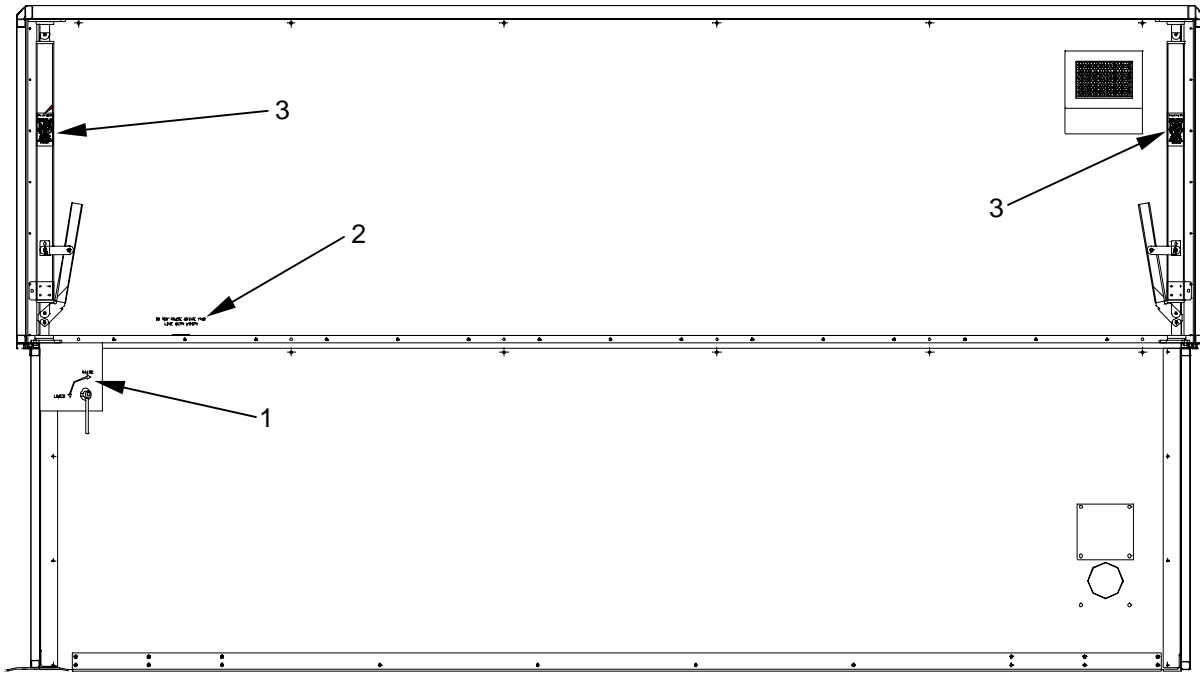

Item Number	Label/Instruction Plate
1	"Raise", "Lower" (with sweeping arrow)
2	"Do Not Raise Above This Line With Winch" (see detail below)
3	"CAUTION Ensure the (2) Lifting/Locking Base Plate Pins Are In Their Slots Before Rotating The Lifting/Locking Assy Handle To Its Final Up Position, Otherwise Damage May Occur To The Pulley Retainer Brackets." (see illustration below)

**INSIDE UPPER SECTION WARNING LABEL DETAIL**

**DO NOT RAISE ABOVE THIS  
LINE WITH WINCH**

LIFTING/LOCKING ASSEMBLY LABEL DETAIL

CAUTION

ENSURE THE (2)  
LIFTING/LOCKING  
BASE PLATE PINS  
ARE IN THEIR  
SLOTS BEFORE  
ROTATING THE  
LIFTING/ LOCKING  
ASSY HANDLE TO  
ITS FINAL UP  
POSITION,  
OTHERWISE  
DAMAGE MAY  
OCCUR TO THE  
PULLEY RETAINER  
BRACKETS.

---

**CARGO BED COVER (CBC), TYPE III, 2 1/2 T CARGO TRUCK, LMTV, AND LMTV TRAILER 0005 00  
OPERATION UNDER USUAL CONDITIONS**

---

## **OPERATING THE CARGO BED COVER**

### **INSTALLING THE CARGO BED COVER ON A VEHICLE BED**

Instructions for the installation of the Cargo Bed Cover and Vehicle Mounting Plate (if required) on the bed of a vehicle are covered in WP 0010 entitled Service Upon Receipt.

### **EXTENDING THE CARGO BED COVER TO AN OPERATIONAL POSITION**

#### **CAUTION**

Any excess snow or ice should be cleared from the roof of the Cargo Bed Cover before the CBC is raised or lowered. Excess snow or ice will increase the weight of the upper section of the CBC and place excessive strain on the lifting/lowering components.

The CBC cannot be raised or lowered while ice remains on the side walls. All ice should be removed from the sidewall before the CBC is raised or lowered.

For example, with the 2 1/2T Cargo Truck **(7)**, lower the tailgate and remove the ladder **(1)** from its storage area **(2)** on the inside surface of the tailgate. Install the ladder hooks **(3)** in position on the rear of the vehicle.

To extend the upper section of the CBC, step up on the ladder **(1)** and rotate the outside door handle **(4)** fully clockwise and then back to a horizontal position. Open the upper section **(5)** of the personnel door.



#### **NOTE**

The Cargo Bed Cover upper section should not be entered prior to raising the upper section. Access to the winch handle should be from the outside of the CBC only.

Crouch down and access the winch **(6)** through the upper personnel door opening.

TM 10-5411-233-13&P

CARGO BED COVER (CBC), TYPE III, 2 1/2 T CARGO TRUCK, LMTV, AND LMTV TRAILER 0005 00  
OPERATION UNDER USUAL CONDITIONS

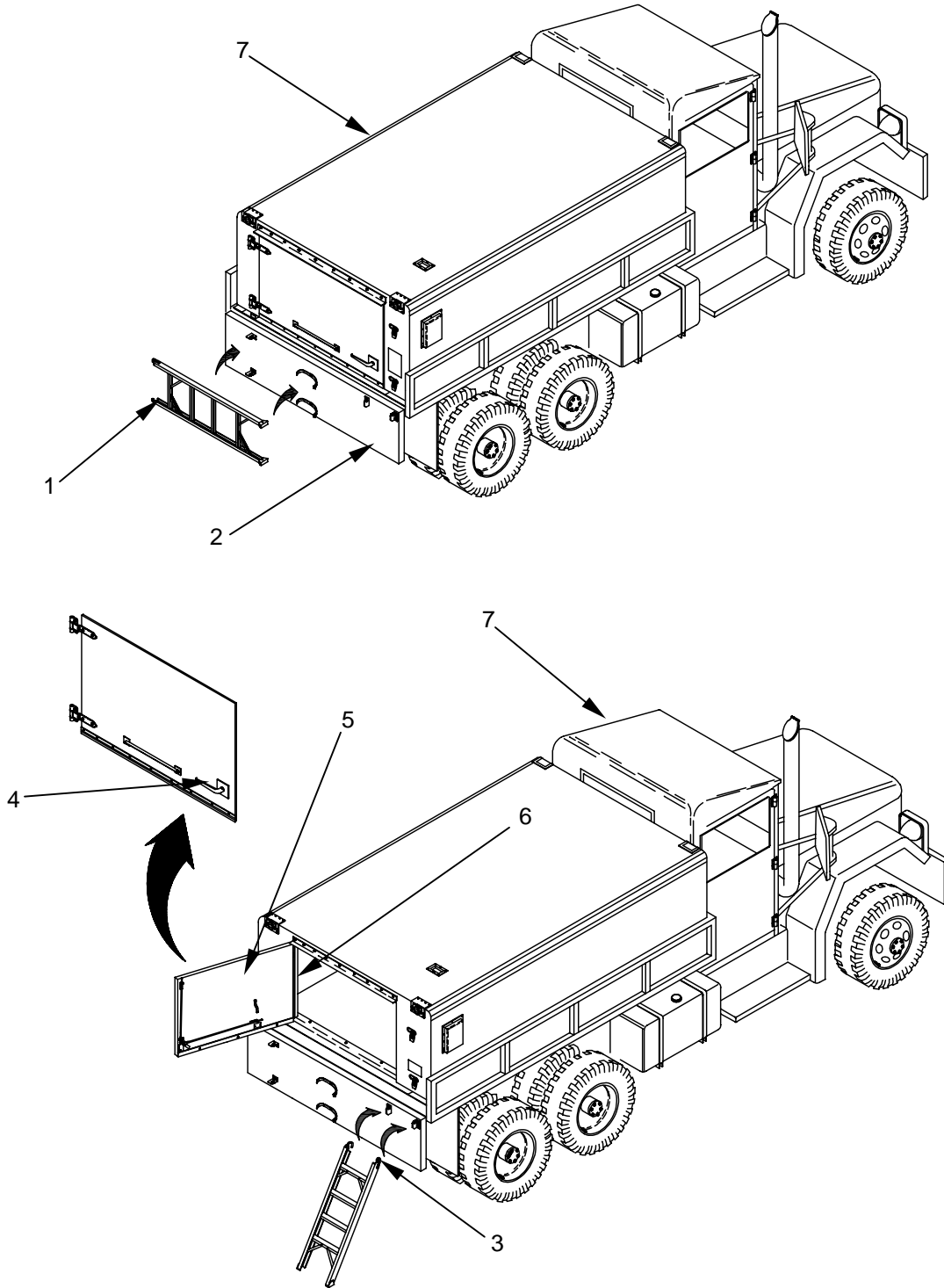

**CARGO BED COVER (CBC), TYPE III, 2 1/2 T CARGO TRUCK, LMTV, AND LMTV TRAILER 0005 00  
OPERATION UNDER USUAL CONDITIONS**

Upon accessing the rear door opening **(1)** of the CBC, locate the winch assembly **(2)** which is just inside the left side of the door opening **(1)**.

If it is not already in position, install the ratchet handle **(3)** by engaging the male portion **(4)** of the handle with the female socket **(5)** located just inside the round opening **(6)** in the winch cover **(7)**.

Move the lever **(8)** on the back of the ratchet handle **(3)** to the right so that the handle engages positively when turned in a clockwise direction.



**WARNING**

Do not raise the upper portion of the CBC past the warning mark on the side wall of the CBC. Raising the upper portion beyond this mark will cause undue stress to the cables and may cause the cables to snap and the upper section of the CBC to drop. Failure to stop at the warning mark when extending the CBC may result in severe injury.

Begin turning the ratchet handle **(3)** in a clockwise direction until the upper extendable section **(9)** of the CBC begins to rise. Continue to raise the upper portion of the CBC until the warning mark line **(10)** is visible on the side wall of the CBC just to the right of the winch assembly **(2)**.

As soon as the warning mark **(10)** is visible, stop turning the ratchet handle. Leave the ratchet handle **(3)** in place on the winch.

When the upper section has been raised to the stenciled warning mark **(10)**, locate the lifting/locking assembly **(11)** nearest the winch which is in its stowed position on the underside of the roof **(12)**.

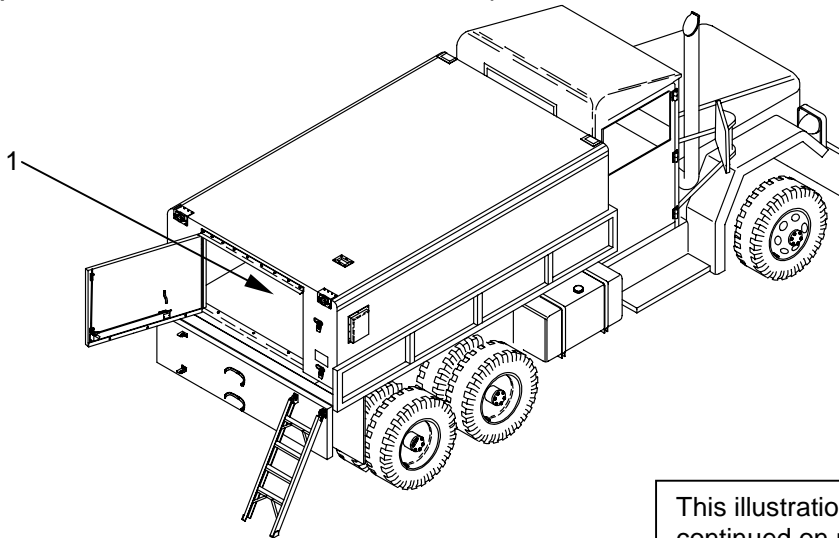

This illustration is continued on next page

**CARGO BED COVER (CBC), TYPE III, 2 1/2 T CARGO TRUCK, LMTV, AND LMTV TRAILER 0005 00  
OPERATION UNDER USUAL CONDITIONS**

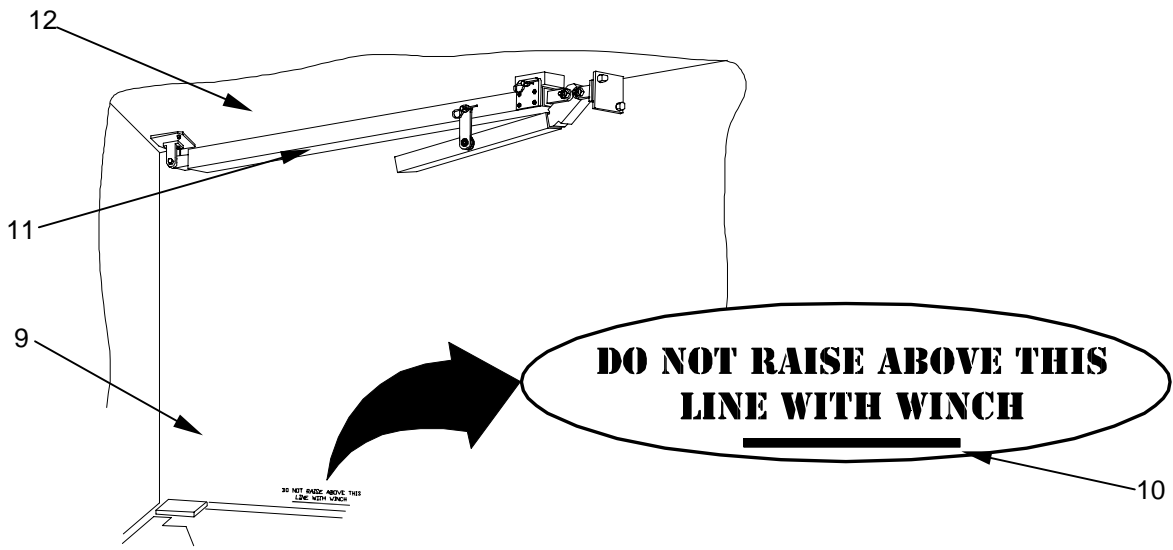
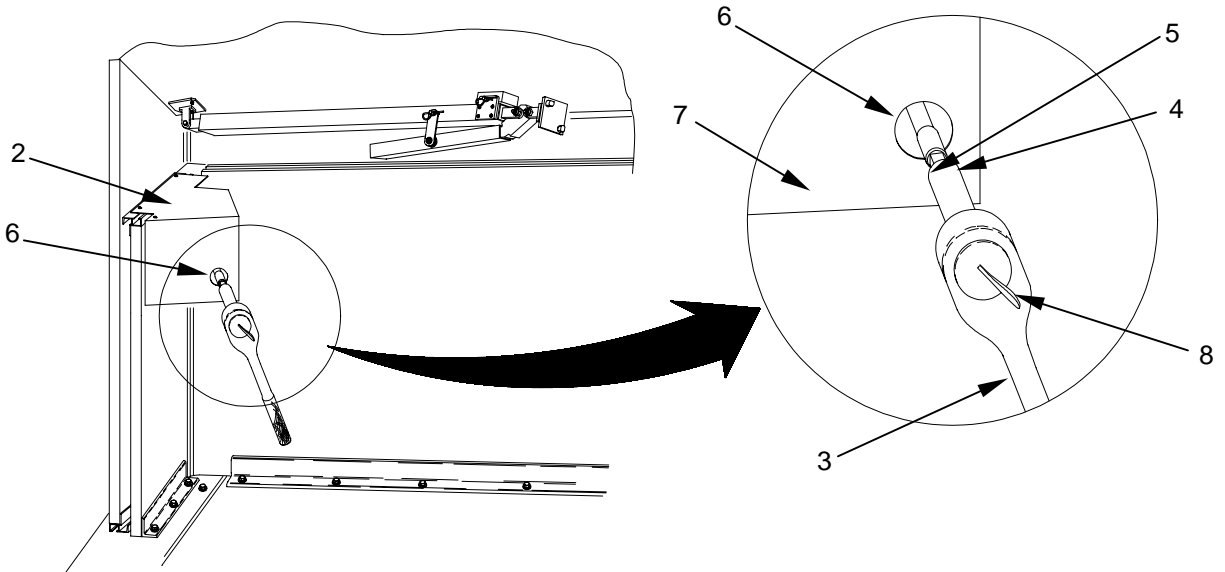

**Positioning the Lifting/Locking Assemblies**



**WARNING**

Be sure to support the lifting/locking assembly with a free hand before removing the clevis pin that secures the assembly to the roof mounted storage block. Removing the clevis pin without supporting the lifting/locking assembly will permit the assembly to swing down freely causing a possible injury.

Remove the hairpin cotter (1) that secures the lifting/locking assembly bracket (2) to the storage block (3) installed on the roof (4) of the upper section. While supporting the lifting/locking assembly (5) with a free hand, pull the clevis pin (6) out and allow the lifting/locking assembly (5) to swing down and come to rest.

When the lifting/locking assembly (5) is almost vertical, rotate the entire assembly 180° for positioning over the lower section corner fitting pulley assembly (9).

Replace the clevis pin (6) in the storage block (3) and reinstall the hairpin cotter (1).

After allowing the lifting/locking assembly (5) to swing down and to rotate 180° from its stowed position, remove the second hairpin cotter (7) that secures the handle (8) to the main body tube of the lifting/locking assembly (5). Swing the handle (8) down until it forms a 90° angle with the main body of the lifting/locking assembly. Replace the hairpin cotter (7) in the clevis pin that secures the handle (8).

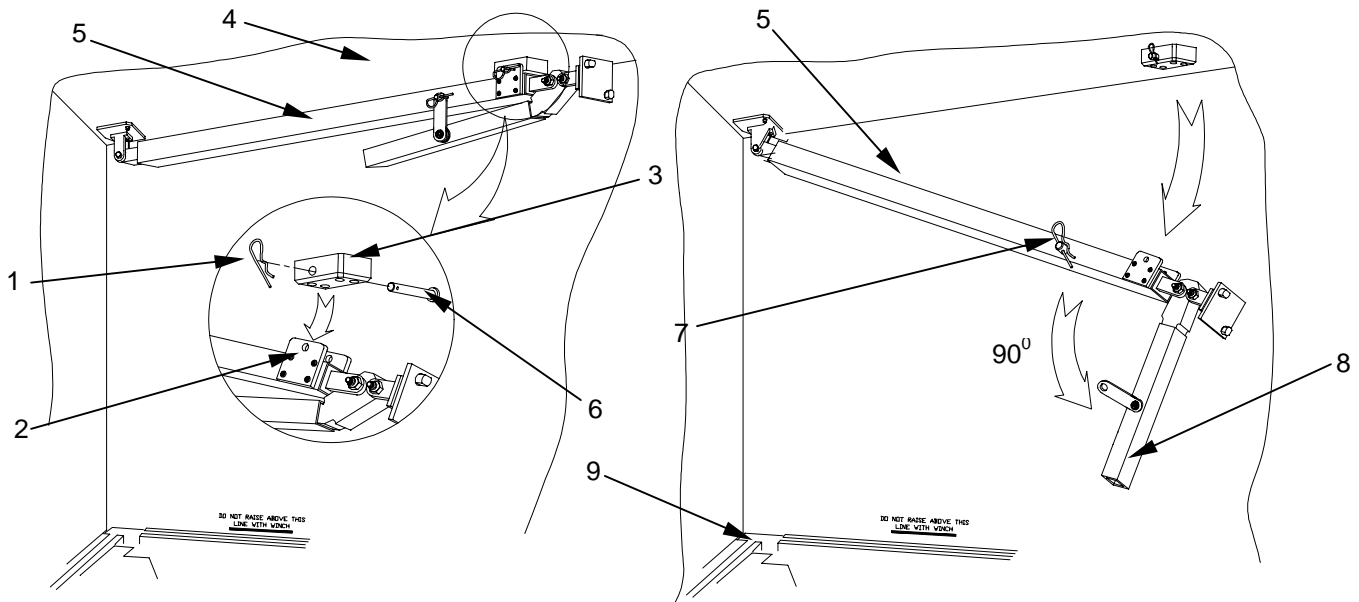

---

**CARGO BED COVER (CBC), TYPE III, 2 1/2 T CARGO TRUCK, LMTV, AND LMTV TRAILER 0005 00  
OPERATION UNDER USUAL CONDITIONS**

---

The base **(3)** at the bottom of the lifting/locking assembly **(1)** is positioned over the corner fitting pulley assembly **(2)** on the lower section. Pins **(4)** protruding from the base **(3)** of the lifting/locking assembly **(1)** are aligned with slots **(5)** located in the interlock extrusion at the corner fitting pulley assembly **(2)**.

In order to move the lifting/locking assembly **(1)** into its final position and properly engage the pins **(4)** on the base **(3)** in the slots **(5)**, it may be necessary to move the handle **(6)** up and down in a wiggling motion to get the assembly into the desired position.

Once the lifting/locking assembly **(1)** is in position, remove the hairpin cotter **(7)** that secures the handle clip **(8)**.

Swing the handle **(6)** up and lock it into position by positioning the hole **(9)** in the handle clip **(8)** over the portion of the clevis pin protruding from the main body tube of the lifting/locking assembly **(1)**. Once in position, replace the hairpin cotter **(7)** removed earlier.

Repeat the above sequence moving clockwise inside the CBC for each of the remaining three lifting/locking assemblies in each corner of the Cargo Bed Cover.

Once all four lifting/locking assemblies are locked in position, the Cargo Bed Cover will be in its fully extended and locked position.



TM 10-5411-233-13&P

**CARGO BED COVER (CBC), TYPE III, 2 1/2 T CARGO TRUCK, LMTV, AND LMTV TRAILER 0005 00  
OPERATION UNDER USUAL CONDITIONS**

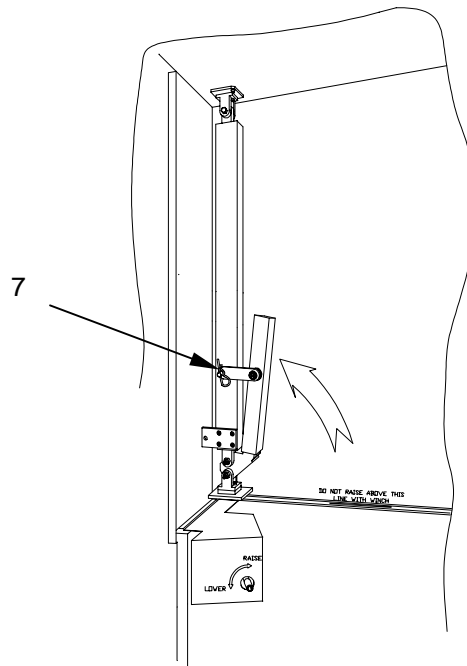
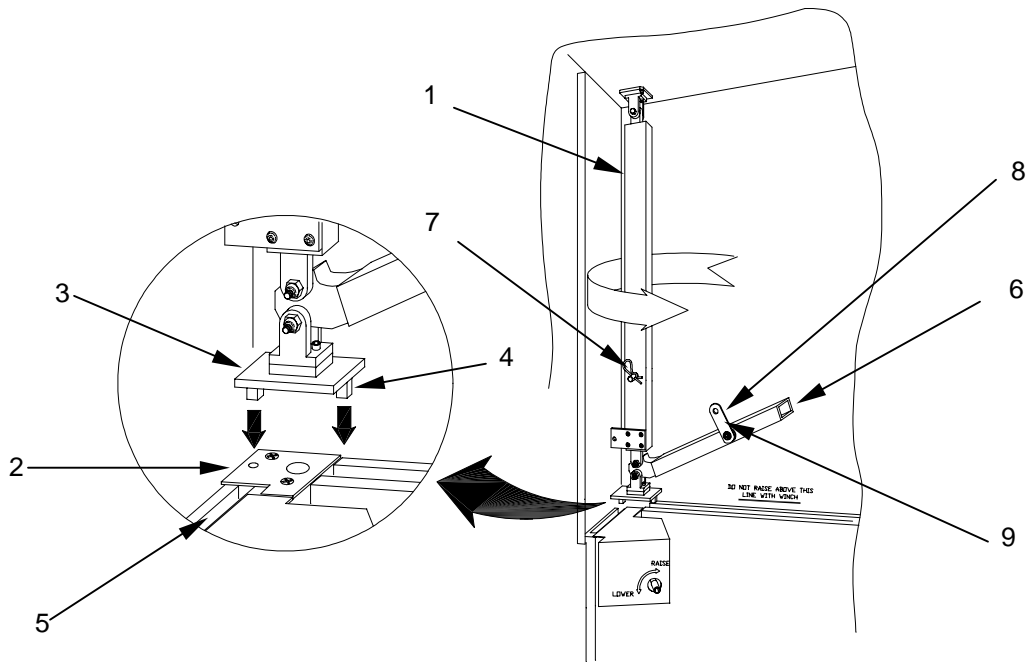

**CARGO BED COVER (CBC), TYPE III, 2 1/2 T CARGO TRUCK, LMTV, AND LMTV TRAILER 0005 00  
OPERATION UNDER USUAL CONDITIONS**

**ASSEMBLING THE PERSONNEL DOOR**

**Removing the lower personnel door panel from its stowage location.** Before the CBC is retracted, the lower section of the personnel door panel is separated from the upper personnel door and stowed. Once the CBC is in its fully extended position, the lower personnel door panel **(1)** must be installed under the upper personnel door section.

The lower personnel door panel **(1)** is stowed just inside the door opening on the inside roof surface **(2)** of the CBC.

To remove the lower personnel door panel **(1)** from its stowage location **(3)** on the underside of the roof **(2)**, stand inside the CBC facing the door opening while under the door panel.



**WARNING**

Be sure to support the lower personnel door panel with a free hand before removing the three hand knobs with threaded studs that secure the door panel to its stowage bracket on the underside of the roof. Removing the hand knobs with threaded studs without supporting the door panel will permit the assembly to fall freely, causing a possible injury.

Support the lower personnel door panel **(1)** with a free hand and remove the three hand knobs with threaded studs **(4)** that secure the top edge **(5)** of the door panel to the left hand “Zee” bracket **(6)**.

Lower the top edge **(5)** of the door panel until the lower edge **(7)** of the door panel can be removed from the right hand “Zee” bracket **(8)**. Lower the door panel from its stowage location and set near the door opening along with the three hand knobs with threaded studs **(4)**.

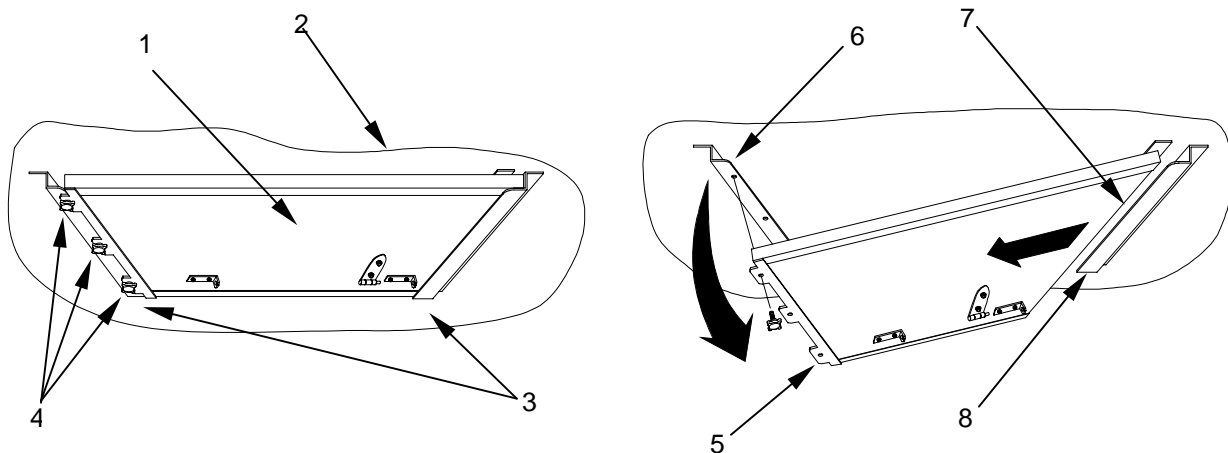

---

**CARGO BED COVER (CBC), TYPE III, 2 1/2 T CARGO TRUCK, LMTV, AND LMTV TRAILER 0005 00  
OPERATION UNDER USUAL CONDITIONS**

---

**Installing the lower personnel door panel to the upper door panel.** Once the lower door panel (1) has been lowered from its stowage location, remove the hex head bolts and washers (2) that are temporarily securing the lower panel door hinge (3) to the inside surface (4) of the lower door panel (1) with a socket wrench. Remove the hinge (3) and spacers (14). Note that there are a total of three spacers between the hinge and the door surface. Two spacers are placed beneath the hole closest to the hinge pivot pin and one spacer is placed beneath the remaining hole. The spacers must always remain in these positions relative to the hinge pivot pin.

Install the hinge (3) in its permanent location on the lower left corner (5) of the outside surface (6) of the lower personnel door panel by placing the spacers (14) in position over the threaded inserts (4). Be sure to replace the spacers between the hinge and the door surface as detailed above with two spacers closest to the hinge pivot pin. Place the hinge in position so that the pivot pin (10) is outside the edge of the door. Install the hex head bolts and washers (2) removed earlier and tighten securely.

Open the upper personnel door panel (7).

Place the lower personnel door panel (1) and the three hand knobs with threaded studs (8) and lockwashers (15) (both removed earlier) in the vicinity of the door opening (9) and within easy reach.

Place the lower personnel door panel hinge pin (10) in the hinge pivot block (11) located at the lower left corner of the personnel door opening (9) and mate the lower door panel (1) to the upper door panel (7). When properly installed, the tabs (12) on the lower door panel (1) will fit into the cutouts (13) of the upper door panel (7).

Secure the lower panel (1) to the upper panel (7) with the three hand knobs with threaded studs (8).

### **CAUTION**

When using the three hand knobs, avoid cross threading. Damage to threaded studs may occur.

TM 10-5411-233-13&P

CARGO BED COVER (CBC), TYPE III, 2 1/2 T CARGO TRUCK, LMTV, AND LMTV TRAILER 0005 00  
OPERATION UNDER USUAL CONDITIONS

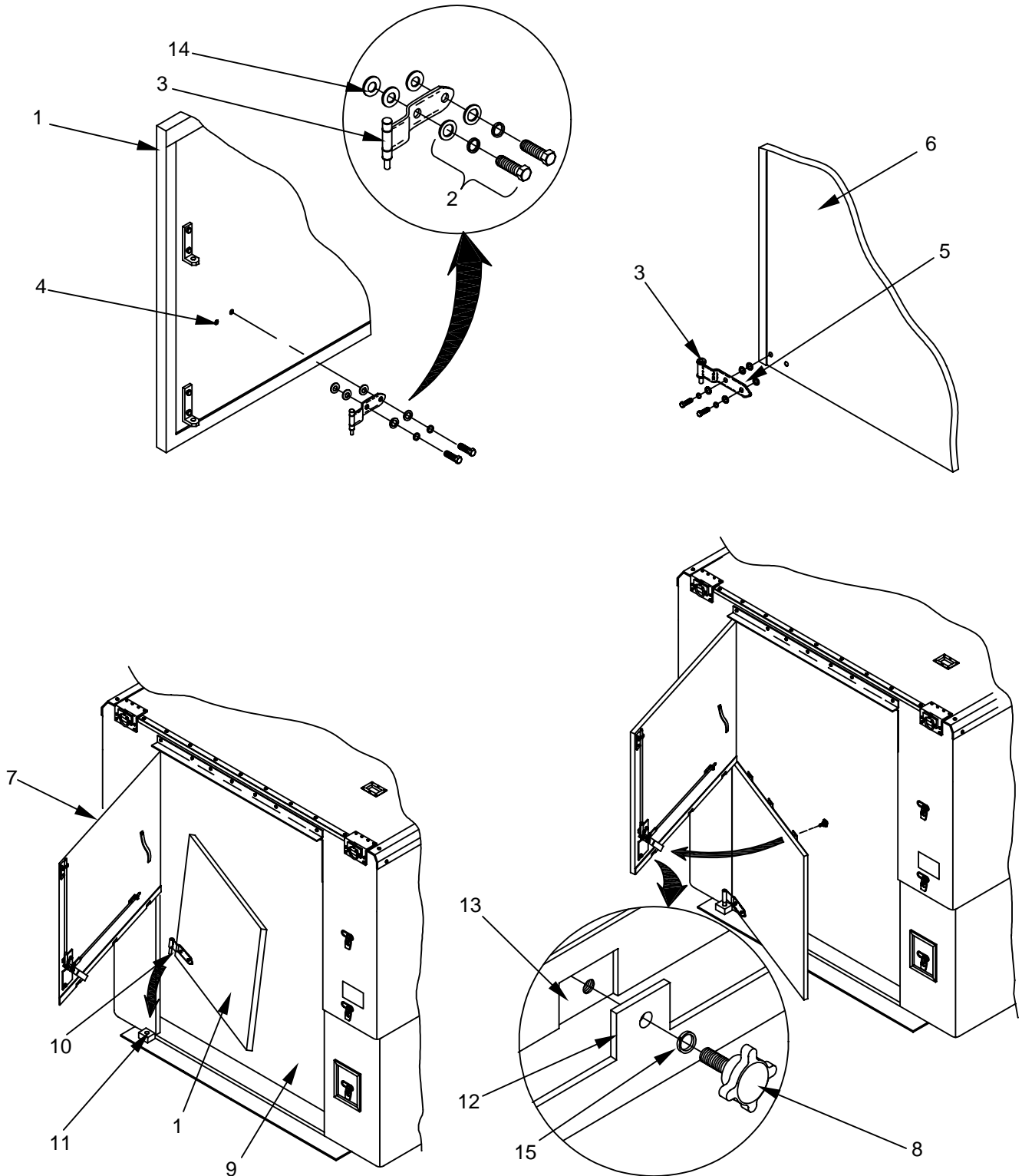

0005 00-10

**CARGO BED COVER (CBC), TYPE III, 2 1/2 T CARGO TRUCK, LMTV, AND LMTV TRAILER 0005 00  
OPERATION UNDER USUAL CONDITIONS**

**Installing the Lower Door Latch Rod.** When the CBC has been retracted and the lower door panel is in its storage location, the lower door latch rod (1) is stored on the inside surface (2) of the upper door panel (3).

To install the lower door latch rod (1) in its operational position, remove the hairpin cotter (4) that secures the upper end (5) of the door latch rod (1) to the door latch mechanism (6).

Slide the door latch rod (1) out of its storage guide (7) on the upper door panel (3).

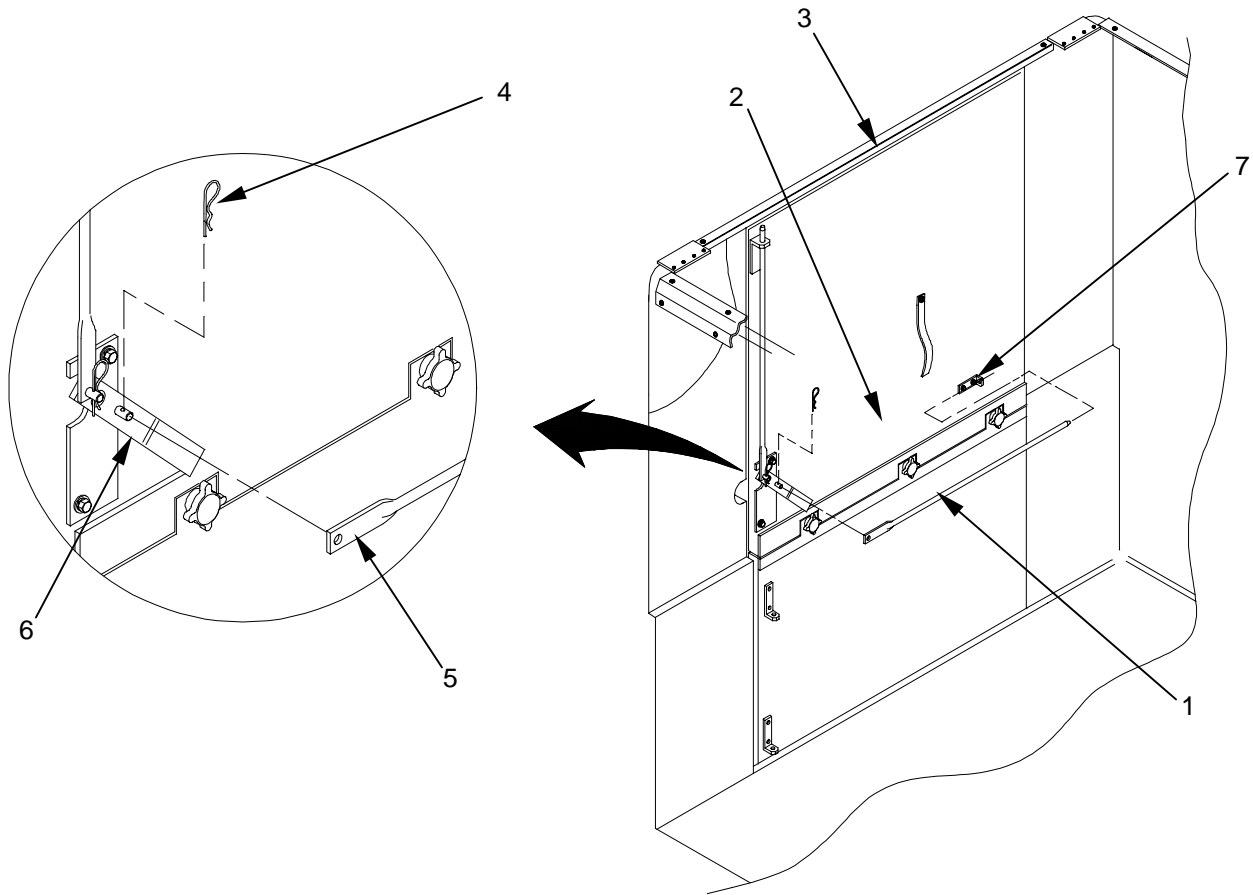

**CARGO BED COVER (CBC), TYPE III, 2 1/2 T CARGO TRUCK, LMTV, AND LMTV TRAILER 0005 00  
OPERATION UNDER USUAL CONDITIONS**

Install the lower door latch rod (1) in its operational position by sliding it down through the two door latch rod guides (8) located on the lower door panel (9).

Engage the upper hole (10) on the door latch rod (1) onto the pin (11) of the door latch (6) from which it was removed in an earlier step. Install the hairpin cotter (4) to secure the door latch rod (1).

Test the action of the door latch (6) by opening and closing the assembled personnel door. Ensure that the door closes properly, that the door latch rods at the upper and lower edges of the door engage properly in their contact points, and that the center case latch engages the strike plate properly.

Make sure that the door operates freely and that the weather seal surrounding the door is positioned properly to block all openings. If the personnel door does not operate smoothly, check to make sure that the lower panel of the personnel door has been installed correctly and that the tabs and cutouts on the inside surface of the personnel door are aligned correctly. Ensure that the three hand knobs with threaded studs are securely tightened.

Once the personnel door has been properly installed, the fully extended Cargo Bed Cover is ready for use.

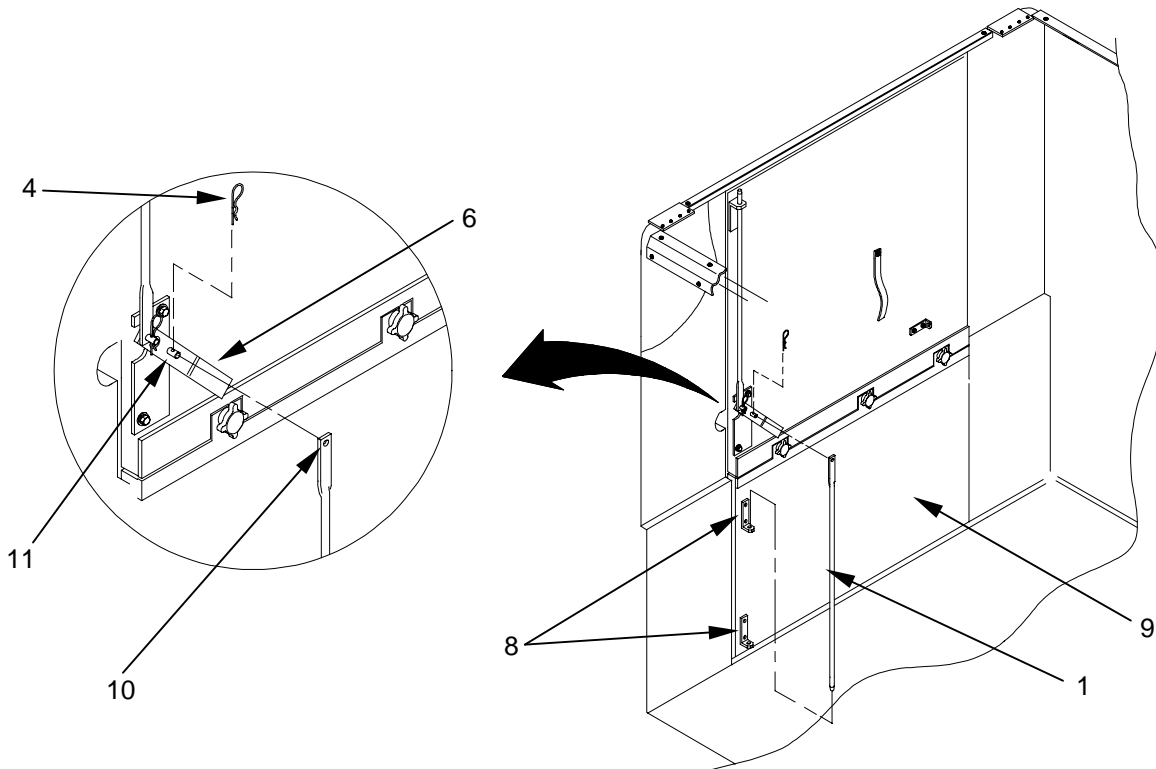

---

**CARGO BED COVER (CBC), TYPE III, 2 1/2 T CARGO TRUCK, LMTV, AND LMTV TRAILER 0005 00  
OPERATION UNDER USUAL CONDITIONS**

---

**OPERATING THE PERSONNEL DOOR**



---

**WARNING**

---

The Personnel Door to the Cargo Bed Cover must remain open while occupied. Failure to do so may result in suffocation or heat stress.



---

**WARNING**

---

The Personnel Door to the Cargo Bed Cover must be locked in the fully open position or secured in the closed position at all times. If not secured, wind gusts may cause the door to close or open violently resulting in damage to the CBC and injury to personnel.

Once the Cargo Bed Cover is in its fully extended position, entry to the CBC can be gained through the Personnel Door **(1)**.

To open the personnel door **(1)**, rotate the door handle **(2)** up to a vertical position **(3)**. In this position, the door latch rods **(4)** on the inside of the door release from their contact points at the top **(5)** and bottom **(6)** of the door and the center case latch **(7)** near the door handle **(2)** releases from its contact point **(8)**.

The door latching mechanism locks in place by rotating the door handle **(2)** down to a vertical position **(13)**. In this position, the door latch rods **(4)** on the inside of the door engage in their contact points at the top **(5)** and bottom **(6)** of the door and the center case latch **(7)** near the door handle **(2)** engages into its contact point **(8)**.

When the door handle **(2)** is in the horizontal position it may be padlocked **(10)** from the outside. If the personnel door **(1)** is for any reason padlocked with personnel inside, they may exit the CBC by using the inner door handle **(11)** of the personnel door. The inner door handle has a center case latch with an override feature which permits the handle to be rotated from the inside of the CBC, even if the outside door handle is padlocked.

If the personnel are locked inside the CBC and the tailgate of the vehicle is up, a secondary exit can be created by separating the lower door panel from the upper door panel and rotating the inner door handle. In this case, the lower door panel is removed from the door as detailed in the section entitled "Using the Secondary Exit".

The personnel door may also be opened and closed from the inside of the CBC. When in the closed and locked position, the inner door handle **(11)** is rotated counterclockwise and will point up at approximately

**CARGO BED COVER (CBC), TYPE III, 2 1/2 T CARGO TRUCK, LMTV, AND LMTV TRAILER 0005 00  
OPERATION UNDER USUAL CONDITIONS**

a 45 degree angle from horizontal. To open the door, the inside handle (11) is rotated clockwise and points down at approximately a 45 degree angle.

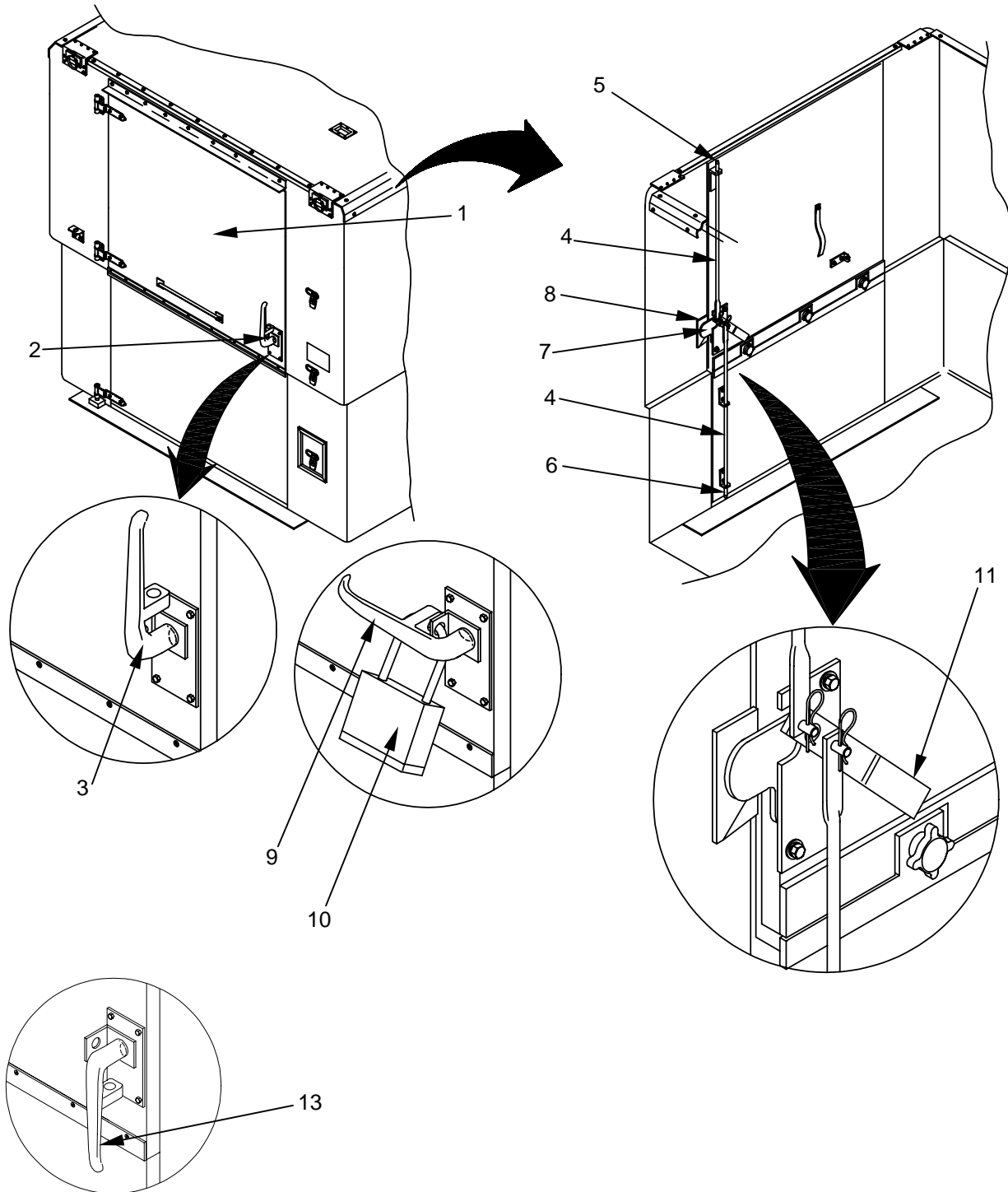



---

**CARGO BED COVER (CBC), TYPE III, 2 1/2 T CARGO TRUCK, LMTV, AND LMTV TRAILER 0005 00  
OPERATION UNDER USUAL CONDITIONS**

---

**Exiting the CBC from the inside when the door has been padlocked.** The Cargo Bed Cover personnel door may be opened from the inside even if it has been padlocked from the outside. This provides any personnel that may be locked inside a means of emergency exit.

To open the personnel door from the inside of the CBC, grasp the handle on the inside of the personnel door and rotate in a counterclockwise direction.

**Using the secondary exit.** The secondary exit **(1)** may only be used if the Cargo Bed Cover is in its fully extended position. It permits personnel to exit the interior of the CBC even if the tailgate of the vehicle is in the up and locked position.

The secondary exit is created by separating the upper personnel door **(1)** from the lower personnel door **(2)** from the inside of the CBC. This creates a situation where the upper door **(1)** can swing open while the lower door panel **(2)** remains in place, allowing personnel to exit.

To create the secondary exit from the interior of the CBC, remove the hairpin cotter **(3)** that secures the lower door latch rod **(4)** to the door latch mechanism **(5)**.

Loosen the three hand knobs with threaded studs **(6)** that secure the lower door panel **(2)** to the upper door panel **(1)**.

Exit the CBC through the opening **(7)** above the lower personnel door panel **(2)**.

TM 10-5411-233-13&P

**CARGO BED COVER (CBC), TYPE III, 2 1/2 T CARGO TRUCK, LMTV, AND LMTV TRAILER 0005 00  
OPERATION UNDER USUAL CONDITIONS**

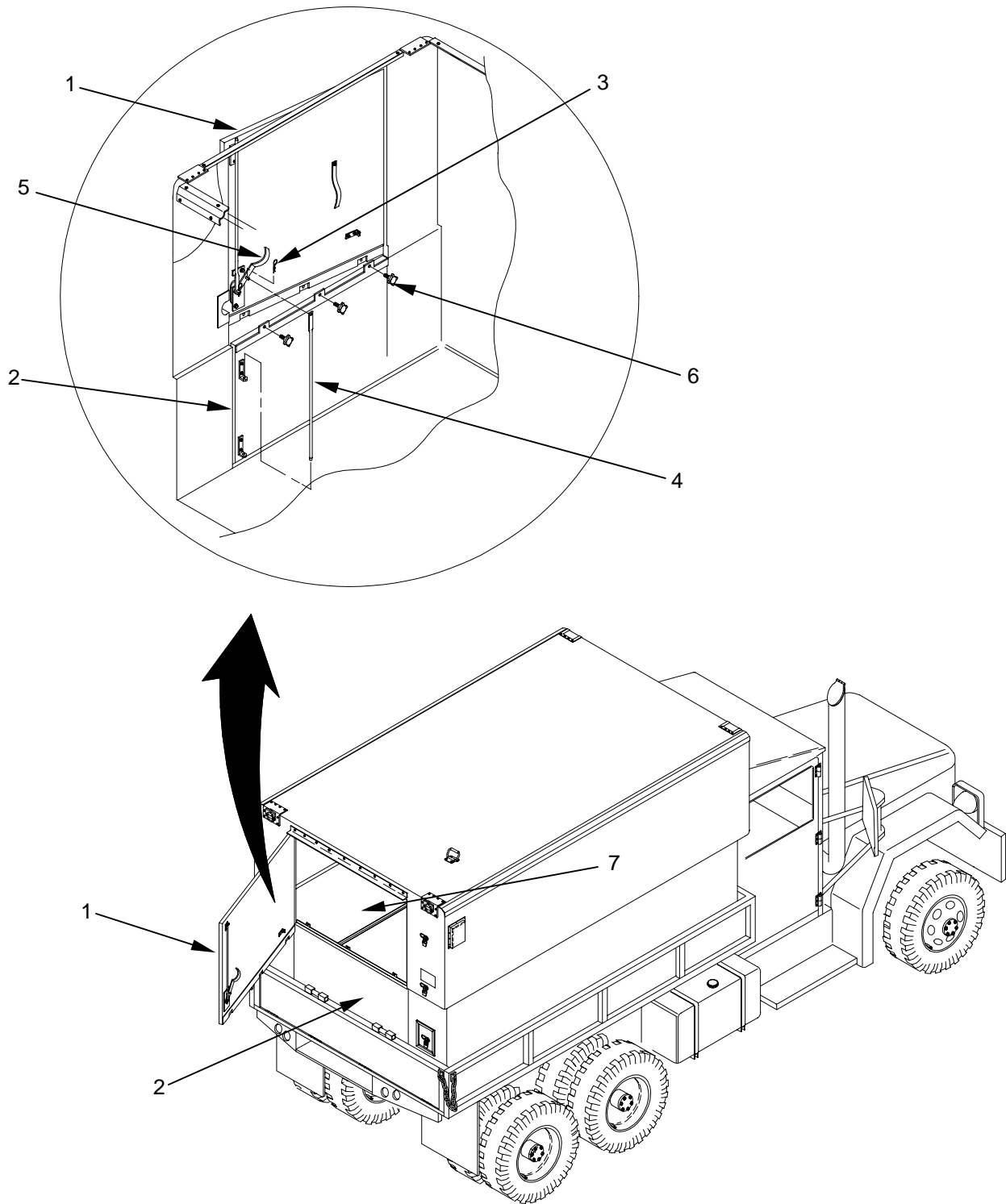

**CARGO BED COVER (CBC), TYPE III, 2 1/2 T CARGO TRUCK, LMTV, AND LMTV TRAILER 0005 00  
OPERATION UNDER USUAL CONDITIONS**

**Using the Door Stop/Hold Open Device.** The door stop/ hold open device (1) is a pivoting bar located on the outside of the personnel door (2). It is used to secure the personnel door in an open position.

To use the door stop/hold open device, pull the hairpin cotter (3) on the right bracket (4) of the device and remove the clevis pin (5). The hairpin cotter (3) is attached to the arm by means of a lanyard (6).

Swing the arm (1) to the left and open the personnel door (2) until the hole (7) at the end of the arm (1) is aligned with the hole (8) in the bracket (9) mounted to the left of the personnel door (1).

Install the clevis pin (5) through the holes (7, 8) in the arm and the bracket. Install the hairpin cotter (3) in the clevis pin (5).

To release the door stop/hold open device and allow the personnel door to close, simply reverse the above procedure.

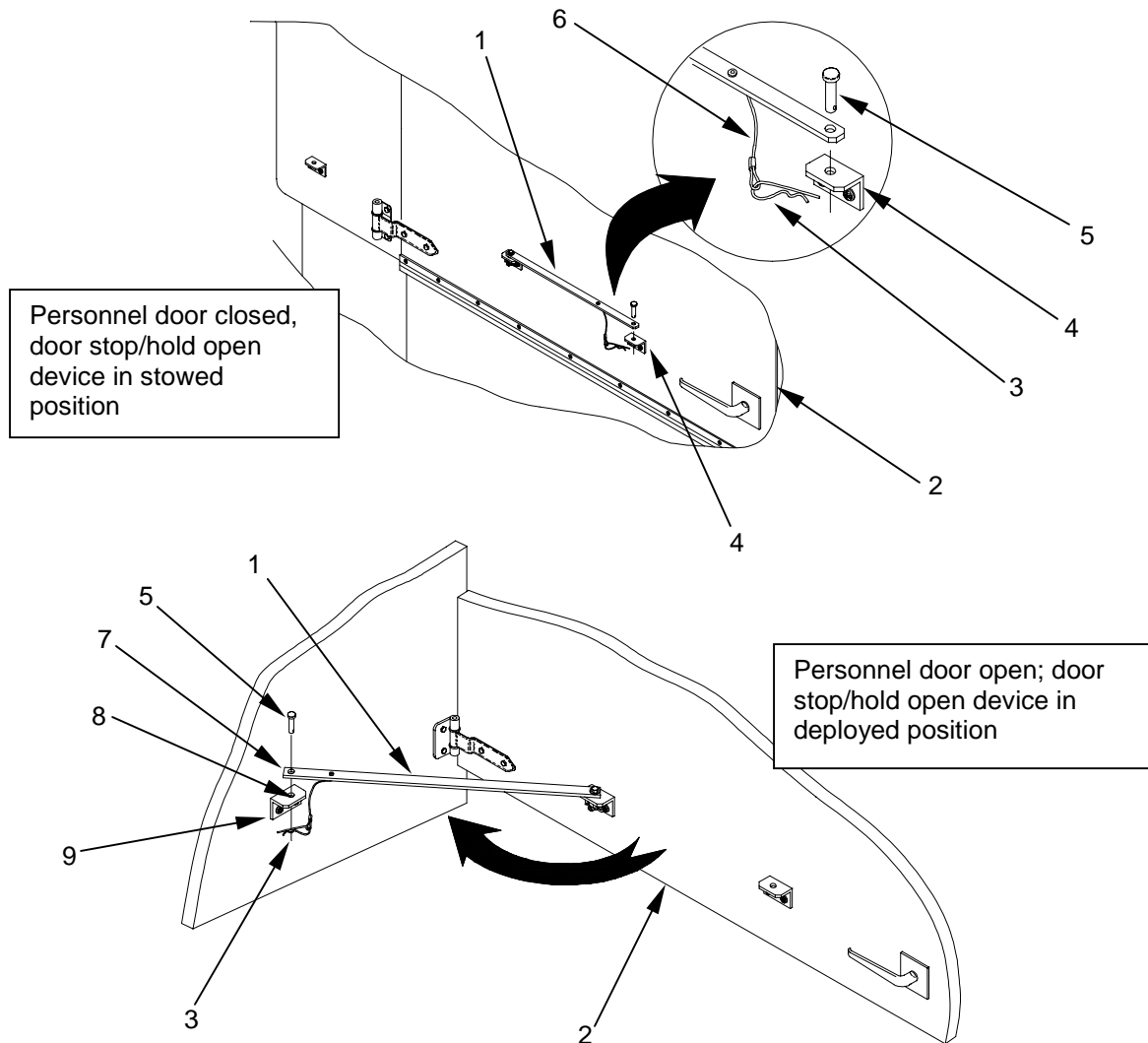

---

**CARGO BED COVER (CBC), TYPE III, 2 1/2 T CARGO TRUCK, LMTV, AND LMTV TRAILER 0005 00  
OPERATION UNDER USUAL CONDITIONS**

---

**PREPARING THE POWER AND SIGNAL LINE PORTS FOR USE**



**NOTE**

The power and signal line port cover on a new CBC may adhere to the side wall due to new paint. It may require pushing the cover from the outside of the CBC to free the cover from the sidewall.

There are two power and signal line ports on the lower stationary section **(1,2)** of the CBC. These ports are designed to permit power and signal cables to enter and/or exit the interior of the CBC.

Both ports are located on the side walls **(3)** of the CBC. One is located on the driver side **(4)** at the forward end and the other is located on the passenger side **(5)** toward the forward end of the CBC.

Each port is lined with an aluminum tube **(6)** to protect the cables from cuts and abrasion. A square blackout panel **(7)** is provided that permits the port to be covered when not in use.

To unblock the port for use, enter the CBC and remove the four screws **(8)** that attach the blackout panel **(7)** to the hardware installed on the sidewall.

Once removed, move the blackout panel **(7)** in position above the open port **(9)** and align the blackout panel **(7)** with the four holes supplied above the open port **(9)**. Install the four screws **(8)** removed earlier.

If desired, move to the power and signal line port on the opposite side of the CBC and repeat the procedure.

Once the blackout panels have been removed, the power and signal ports are ready for use.

**Re-installing Blockout Panels.** To block the power and signal line ports when not in use, simply reverse the above procedure and remove the four screws **(8)** that attach the blackout panel **(7)** to the side wall.

Put the blackout panel **(7)** in place over the power and signal line port opening **(9)** and install the four screws **(8)**.

CARGO BED COVER (CBC), TYPE III, 2 1/2 T CARGO TRUCK, LMTV, AND LMTV TRAILER 0005 00  
OPERATION UNDER USUAL CONDITIONS

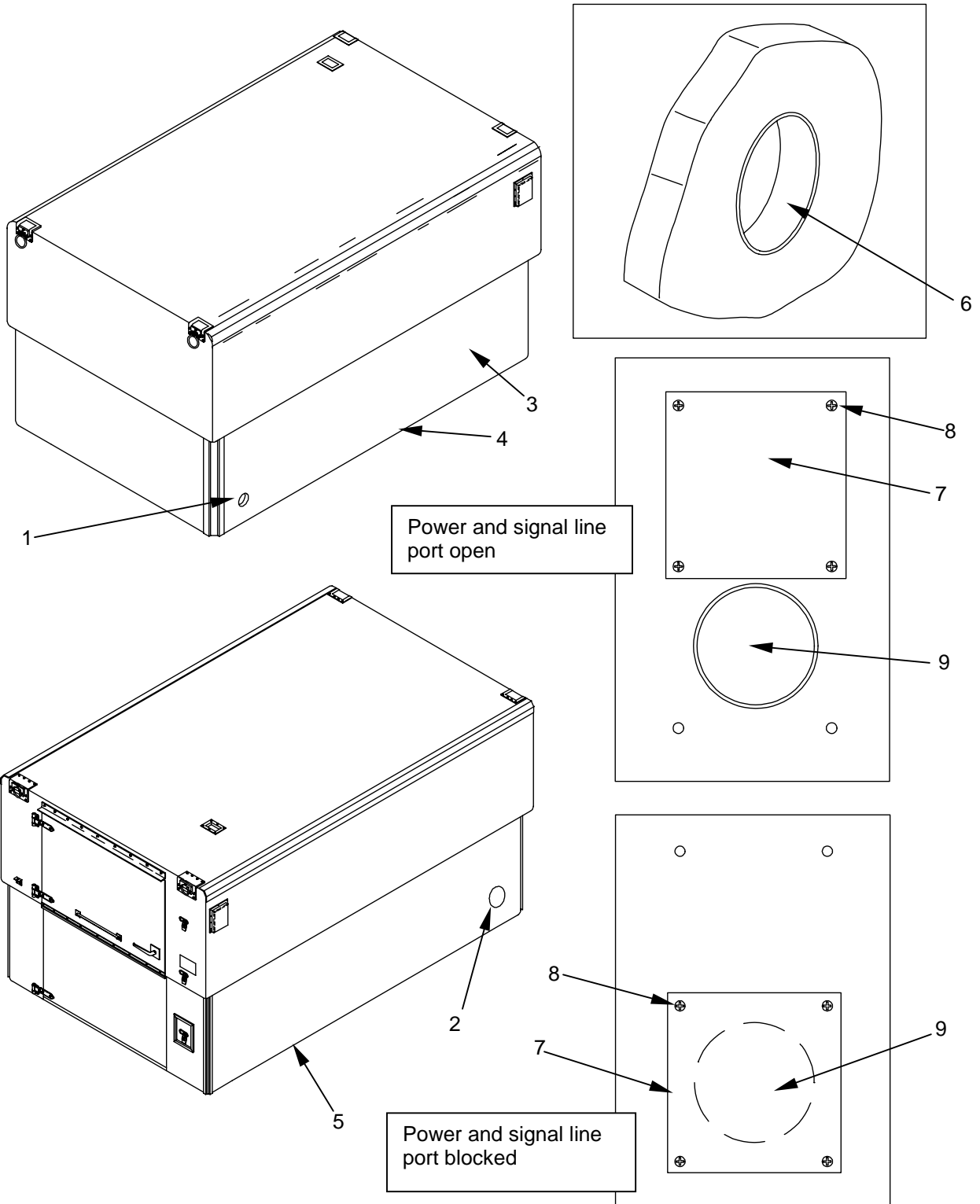

---

**CARGO BED COVER (CBC), TYPE III, 2 1/2 T CARGO TRUCK, LMTV, AND LMTV TRAILER 0005 00  
OPERATION UNDER USUAL CONDITIONS**

---

**HOISTING THE CARGO BED COVER USING THE LIFT RINGS**



---

**WARNING**

---

Do not lift the Cargo Bed Cover (CBC), in its retracted (lowered) position. The CBC must be in its extended (fully raised) position prior to using the lift rings for lifting.



---

**WARNING**

---

Do not use the lift rings to lift a CBC with an installed payload greater than 1100 pounds. Lift rings should only be used to lift an empty CBC that is not mounted to a vehicle.

A Cargo Bed Cover, that has been installed on a vehicle should only be hoisted using the lifting points on the vehicle.

Make sure to use handling equipment rated for the equipment it will be lifting. Do not use handling equipment rated for less than the gross weight of the CBC when handled by itself or the CBC plus the vehicle when the CBC has been installed on a vehicle.

Failure to follow these lift warnings may result in severe injury or death to personnel or damage to equipment.

**CAUTION**

Do not attach a hoisting sling to the CBC lift rings in such a way as to create an angle between the cable and the CBC roof surface that is LESS THAN 45°. Attaching the cable at any angle less than 45° will result in excessive strain on the lift rings which may result in damage to the Cargo Bed Cover.

Lift rings **(1)** are provided on the fore and aft top edges of the Cargo Bed Cover to allow it to be lifted onto and off of a vehicle bed. The lift rings must be used only to lift a CBC that is mechanically detached from the vehicle.

To lift the CBC using the lift rings, the CBC must first be in its fully extended and locked position. Attach the hoisting sling **(2)** to a crane or similar piece of equipment.

**CARGO BED COVER (CBC), TYPE III, 2 1/2 T CARGO TRUCK, LMTV, AND LMTV TRAILER 0005 00  
OPERATION UNDER USUAL CONDITIONS**

Attach the hooks (3) from the hoisting sling to each of the lift rings (1) making sure that they are securely locked in place. The angle created between each cable and the roof surface of the CBC must not be any less than  $45^{\circ}$ .

Hoist the Cargo Bed Cover into the desired position.

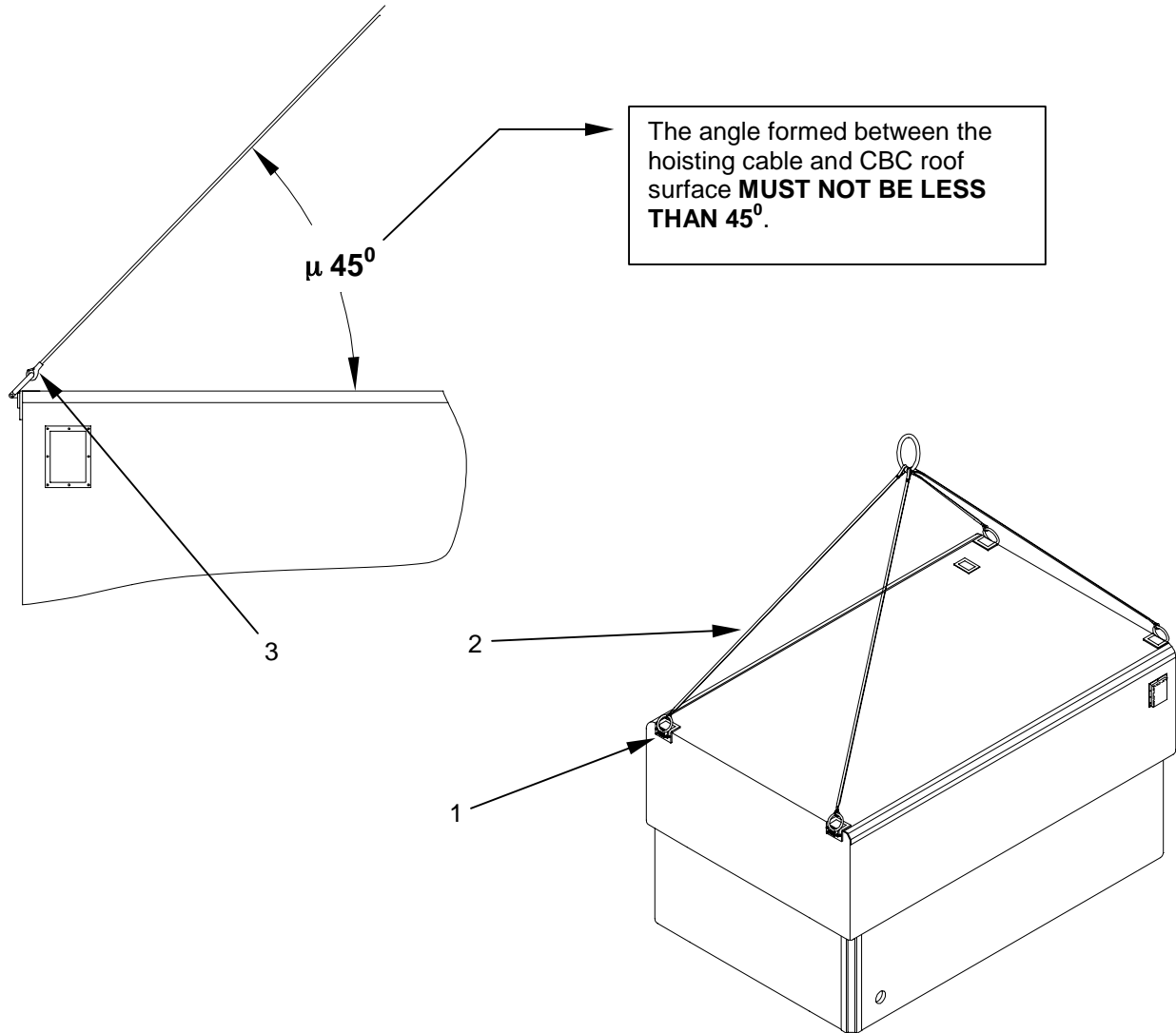

---

**CARGO BED COVER (CBC), TYPE III, 2 1/2 T CARGO TRUCK, LMTV, AND LMTV TRAILER 0005 00  
OPERATION UNDER USUAL CONDITIONS**

---

**HOISTING A VEHICLE WITH AN INSTALLED CARGO BED COVER**



---

**WARNING**

---

Do not use the lift rings to lift a CBC that is installed on a vehicle. Lift rings should be used to lift an empty, non-vehicle-mounted CBC only.

A Cargo Bed Cover that has been installed on a vehicle should be in a retracted condition and only be hoisted using the lifting points on the vehicle.

Make sure to use handling equipment rated for the equipment it will be lifting. Do not use handling equipment rated for less than the gross weight of the CBC when handled by itself or the CBC plus the vehicle when the CBC has been installed on a vehicle.

Failure to follow these lift warnings may result in severe injury or death to personnel or damage to equipment.

To hoist a Cargo Bed Cover while it is installed on a vehicle, the CBC must be retracted. Helicopter rub strips are provided along the length of the roof line to protect the CBC from cables that may rub against the unit while the vehicle is being lifted.

Attach a hoisting sling rated to lift the combined gross weight of the vehicle, Cargo Bed Cover, and payload. Attach the end of the cables at the vehicle lifting points in accordance with the vehicle's technical manual.

Attach the other end of the hoisting sling to a crane or equivalent equipment rated to lift the combined gross weight of the vehicle, Cargo Bed Cover, and payload.

Hoist the vehicle with installed Cargo Bed Cover and move into position in desired location.



**CARGO BED COVER (CBC), TYPE III, 2 1/2 T CARGO TRUCK, LMTV, AND LMTV TRAILER 0005 00  
OPERATION UNDER USUAL CONDITIONS**

**GAINING ACCESS TO THE ROOF OF THE CARGO BED COVER**

**CAUTION**

Be sure to return the lower roof access step to its upright, stowed position prior to retracting the CBC. Failure to stow the lower roof access step will cause damage to the upper section and the step as the upper section is lowered.

To gain access to the roof **(1)** of the CBC when in its fully extended position, flip the hinged foot pads on the lower **(2)** and upper **(3)** roof access steps down so that they are perpendicular to the wall of the CBC and locked in position.

Use the steps to reach the roof of the CBC.

A handhold **(4)** is provided on the roof of the Cargo Bed Cover to assist in climbing on top of the CBC.

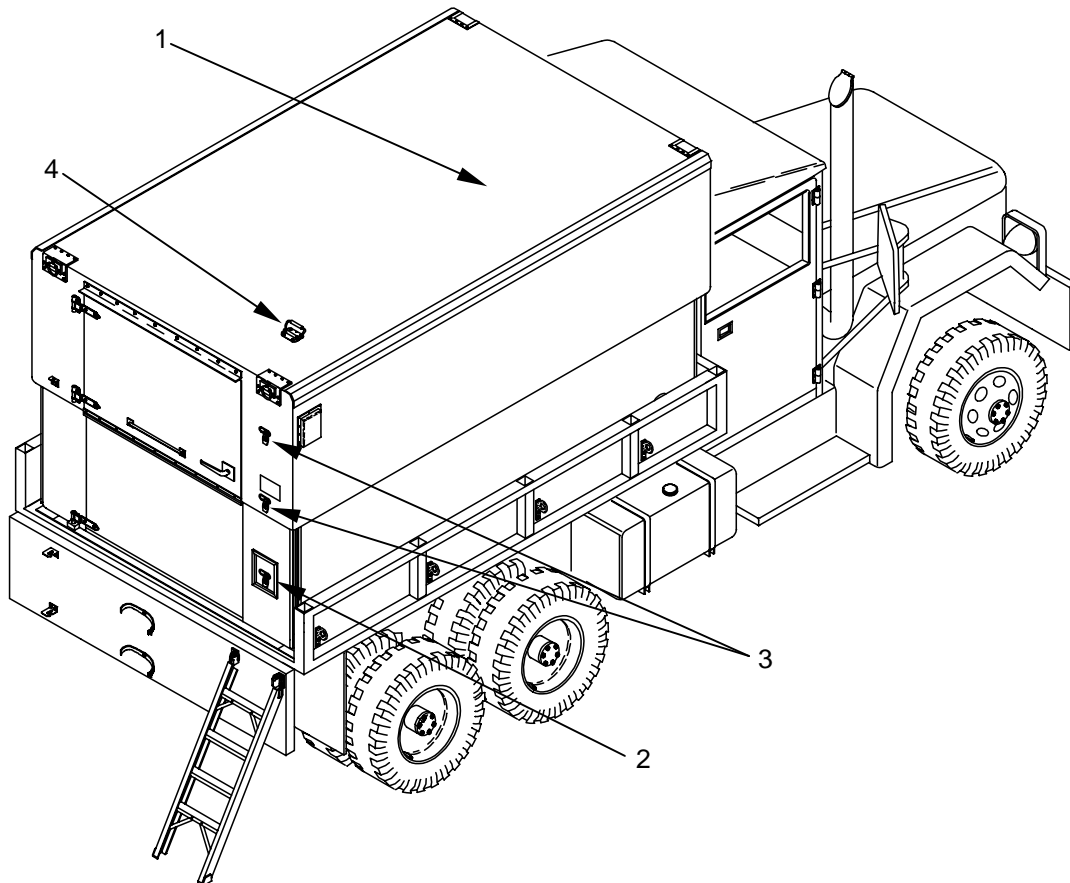

## **RETRACTING THE CARGO BED COVER**

### **CAUTION**

Any excess snow or ice should be cleared from the roof, side walls, and personnel door hinges of the Cargo Bed Cover before the CBC is extended or retracted. Excess snow or ice will increase the weight of the upper section of the CBC and place excessive strain on the lifting/lowering components.

Refer to WP 0006 entitled "Operation Under Unusual Conditions" for more information on raising and lowering the CBC under conditions of excess snow and/or ice.

### **REMOVING AND STOWING THE LOWER PERSONNEL DOOR PANEL**

Before retracting the CBC, the lower personnel door **(1)** must be removed and stowed.

To remove the lower personnel door panel, remove the hair pin cotter **(2)** that secures the lower door latch rod **(3)** to the door latch mechanism **(4)**.

Slide the door latch rod **(3)** up and out of the guides **(16)** on the lower panel **(1)**.

Slide the rod **(3)** horizontally through the guide **(5)** on the upper personnel door panel **(6)**.

Install the hairpin cotter **(2)** removed earlier in place on the door latch mechanism **(4)**.



---

### **WARNING**

---

Be sure to support the lower personnel door panel with a free hand before removing the three hand knobs with threaded studs that secure the lower door panel to the upper door panel. Removing the hand knobs with threaded studs without supporting the door panel will permit the assembly to fall freely, causing possible injury and damage to the lower door panel.



**CARGO BED COVER (CBC), TYPE III, 2 1/2 T CARGO TRUCK, LMTV, AND LMTV TRAILER 0005 00  
OPERATION UNDER USUAL CONDITIONS**

Once the door latch rod has been removed and stowed on the back of the upper door panel, loosen and remove the three hand knobs with threaded studs (7) that secure the lower door panel (1) to the upper door panel (6). Be sure to support the door with a free hand.

While positioned outside the door, lift the lower door panel hinge pin (8) up and out of the hinge pivot hole (9) located in the threshold at the lower left corner of the personnel door opening.

The door hinge (10) on the outside surface (11) of the door is removed and stowed on the inside surface (12) of the door when the lower door panel (1) is stowed on the underside of the roof.

Set the lower door panel (1) on a work surface and remove the screws and washers (13) that secure the hinge (10) to the outside surface (11) of the lower door panel (1). Remove the hinge (10) and spacers (14). Note that there are a total of three spacers between the hinge and the door surface. Two spacers are placed beneath the hole closest to the hinge pivot pin and one spacer is placed beneath the remaining hole. The spacers must always be installed in these positions relative to the hinge pivot pin.

Turn the lower door panel (1) over so that the outside surface (11) is face down. Place the spacers (14) between the hinge and the door surface as detailed above with two spacers closest to the hinge pivot pin. Position the hinge (10) in its stowage location (15) on the inside surface (12) of the door.

Secure the hinge (10) in place using the screws and washers (13) removed in the previous step.

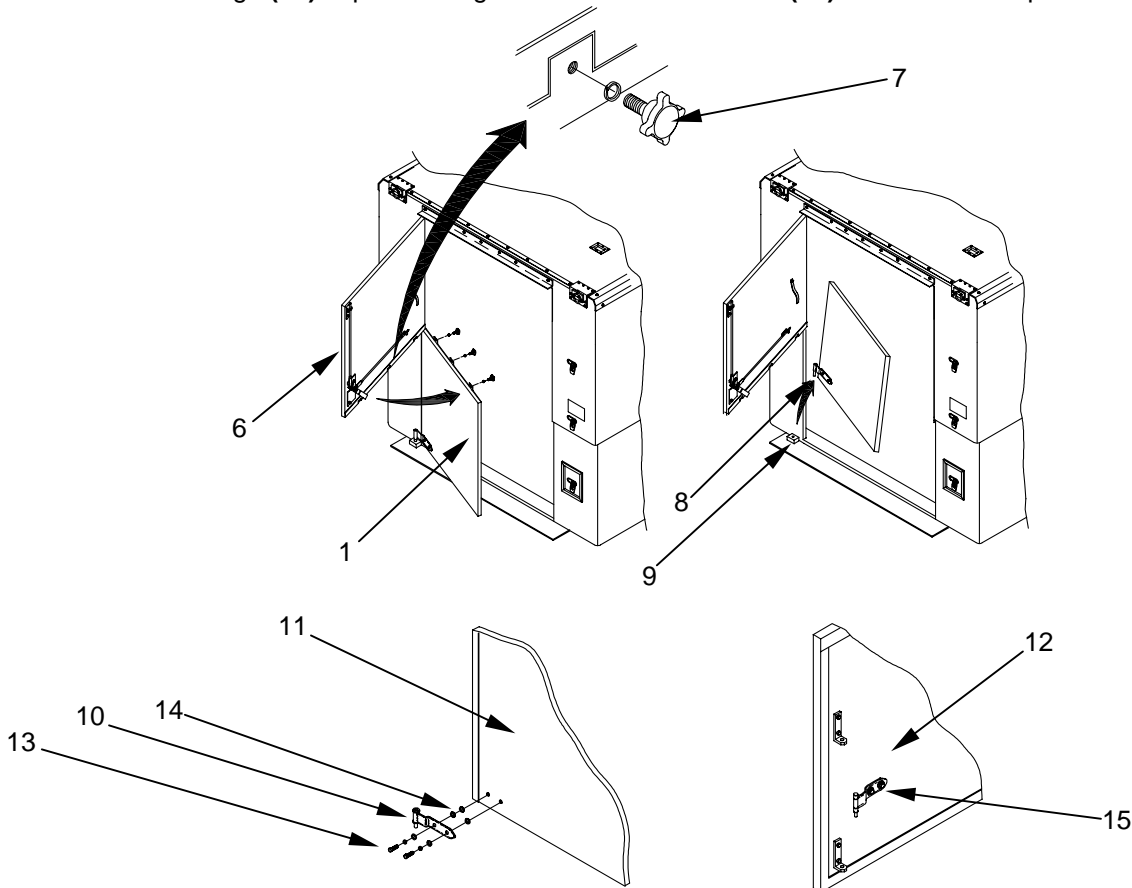

---

**CARGO BED COVER (CBC), TYPE III, 2 1/2 T CARGO TRUCK, LMTV, AND LMTV TRAILER 0005 00  
OPERATION UNDER USUAL CONDITIONS**

---

**Stowing the lower personnel door panel.** The lower personnel door panel **(1)** is stowed on the underside of the roof **(2)** when the CBC is to be retracted.

Once the lower personnel door has been removed and the hinge **(3)** transferred to the inside surface of the door panel, stand under the two “Z” brackets **(4)** installed just inside the personnel door opening.

While holding the lower door panel at an angle **(5)**, slide the bottom edge **(6)** of the lower door panel inside the right hand “Zee” bracket **(7)** just to the right of the rubber strip **(8)** installed on the roof surface. Make sure that the side of the door with the hinge installed (inside surface of door) is facing the floor of the CBC when installed in the bracket.

While holding the panel in place in the right hand bracket **(7)**, swing the upper edge **(9)** of the door panel into position against the left hand “Zee” bracket **(10)**, aligning the holes on the door panel tabs **(11)** with the threaded inserts installed in the left hand bracket **(10)**.

### **CAUTION**

When installing the three hand knobs, avoid cross threading. Damage to threaded studs may occur.

Install the three hand knobs with threaded studs **(12)** and lockwashers **(13)** that were removed when disassembling the personnel door. Take care not to cross-thread the hand knobs into the threaded studs.

TM 10-5411-233-13&P

CARGO BED COVER (CBC), TYPE III, 2 1/2 T CARGO TRUCK, LMTV, AND LMTV TRAILER 0005 00  
OPERATION UNDER USUAL CONDITIONS

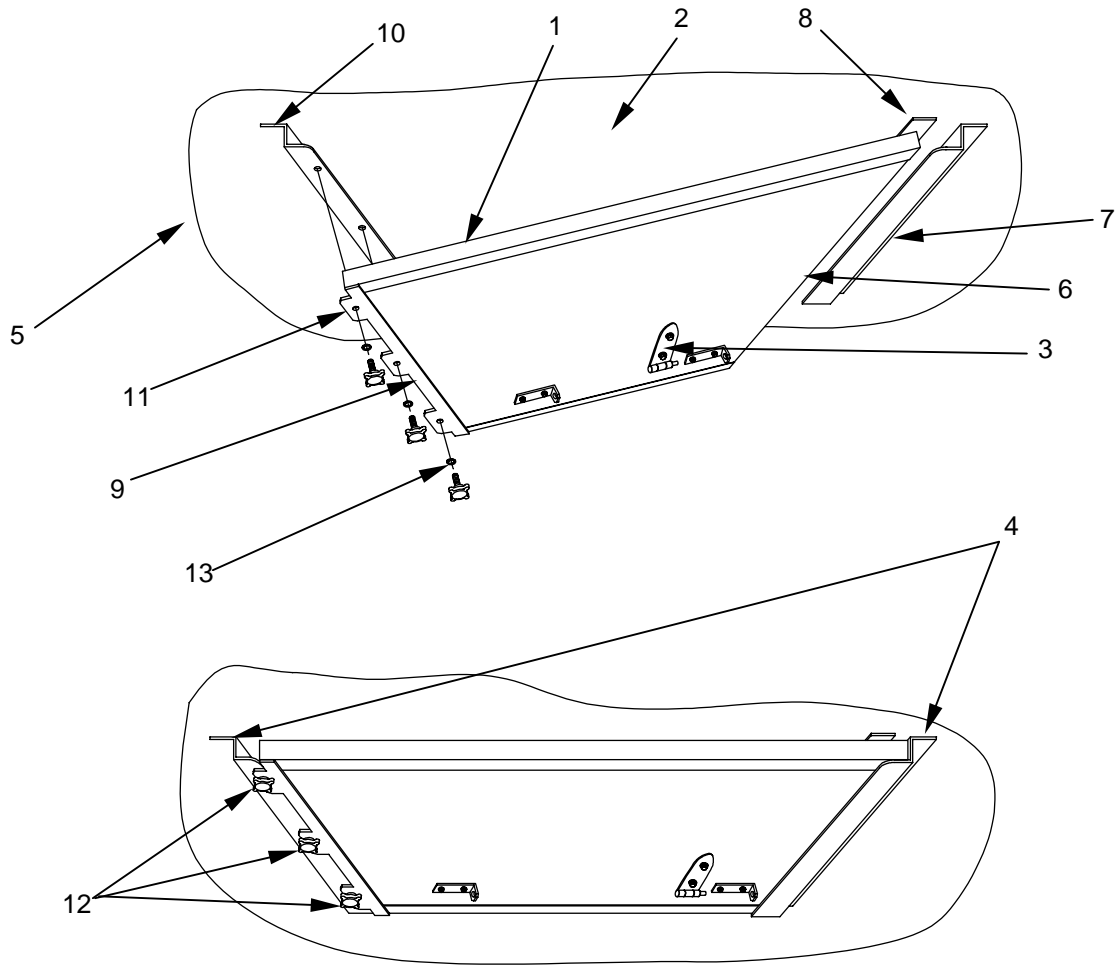

Stowing the Lifting/Locking Assemblies

**CAUTION**

Be sure that the winch cables do not have any slack prior to releasing and stowing the four lifting/locking assemblies. If the cables have slack, move the lever on the ratchet handle to the right and turn the ratchet handle clockwise SLIGHTLY to raise the upper section of the CBC. Turn the ratchet handle just enough to take up any slack in the cables. Do not raise the upper section beyond the warning line on the side wall of the upper section. Raising the upper section of the CBC beyond the warning line may cause the cables to snap. Failure to take out the slack in the winch cables will make it very difficult to release the lifting/locking assemblies.

Once the lower personnel door panel has been stowed, the four lifting/locking assemblies (1) must be released from their vertical position and stowed on the underside of the roof.

To release and stow each of the lifting/locking assemblies (1), remove the hairpin cotter (2) that secures the handle (3) and swing the handle down so that it is approximately perpendicular to the main tube (4) of the lifting/locking assembly (1). Replace the hairpin cotter (2) in the clevis pin.

While moving the handle (3) slightly up and down as needed, disengage the base plate (5) with protruding pins (6) from the slots (7) formed by the interlock extrusion.

When the lifting/locking assembly (1) has been released from the slots (7), remove the hairpin cotter (2) installed in the clevis pin on the main tube (4) and swing the handle (3) up until the hole in the handle clip (8) slides over the clevis pin. Lock the handle (3) in position by installing the hairpin cotter (2) in the clevis pin.

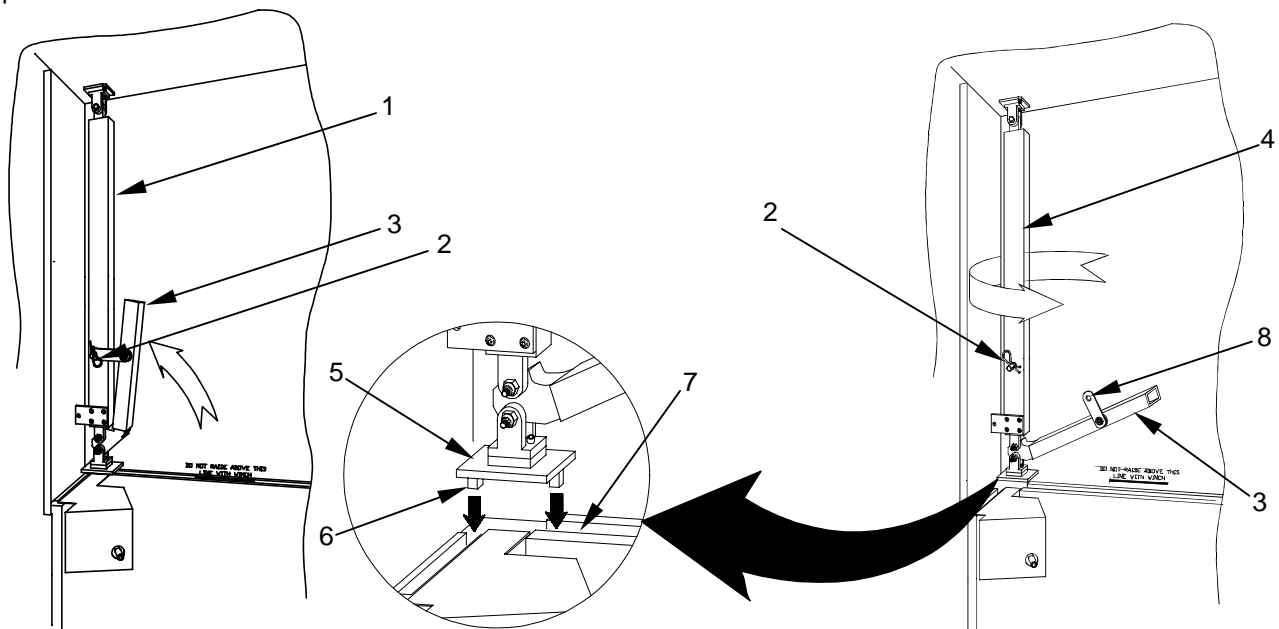

**CARGO BED COVER (CBC), TYPE III, 2 1/2 T CARGO TRUCK, LMTV, AND LMTV TRAILER 0005 00  
OPERATION UNDER USUAL CONDITIONS**

Once the handle (1) is in its locked position, remove the hairpin cotter (2) on the clevis pin (3) installed on the roof stowage block (4) and slide the clevis pin (3) out of the stowage block (4). Keep the hairpin cotter (2) and clevis pin (3) close by.

While swinging the lifting/locking assembly (5) up to its stowage block (4) on the underside of the roof, rotate the entire lifting/locking assembly (5) clockwise. Stow the lifting/locking assembly so that the bracket (6) straddles the stowage block (4). Make sure that the holes (7) in the bracket (6) are aligned with the holes in the stowage block (4) and protruding pins (8) in the lifting/locking assembly base go into the recess openings in the cargo bed cover roof.

Install the clevis pin (3) removed earlier through one side of the bracket (6), through the stowage block (4), and out the opposite side of the bracket (6).

Install the hairpin cotter (2) removed earlier in the end of the clevis pin (3).

Repeat this procedure for each of the three remaining lifting/locking assemblies until all are in their stowed positions on the underside of the roof.

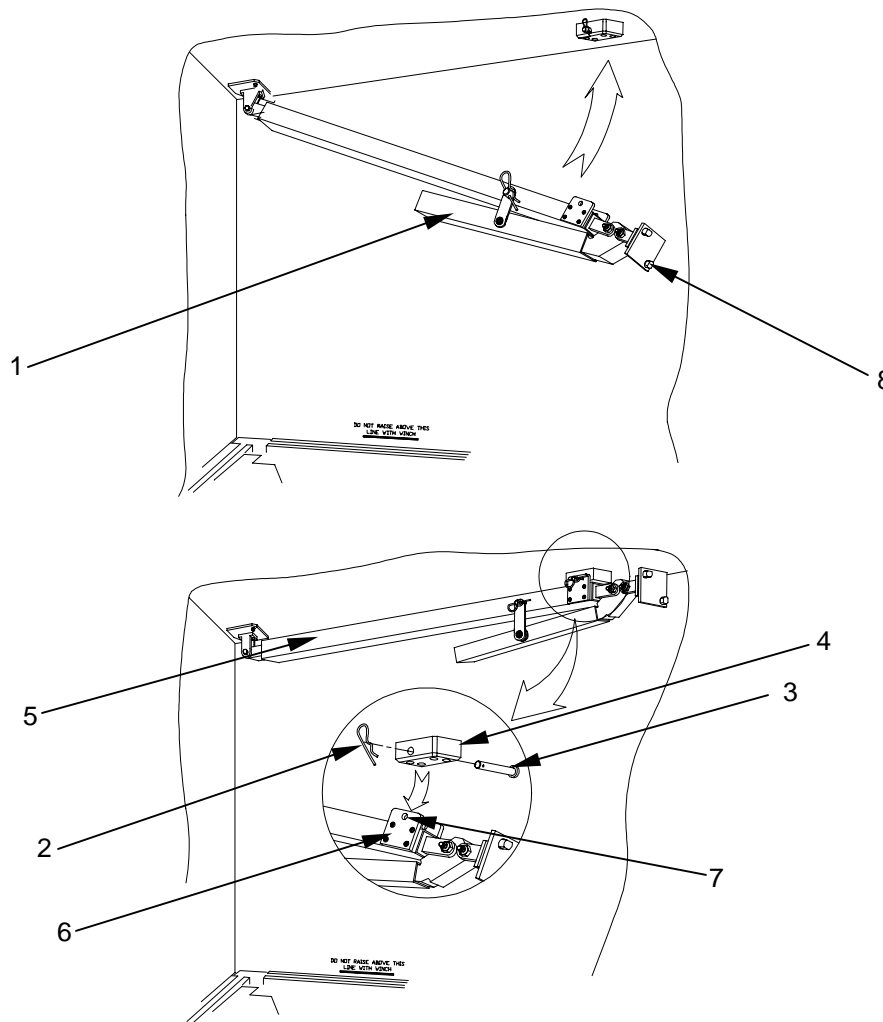



---

**CARGO BED COVER (CBC), TYPE III, 2 1/2 T CARGO TRUCK, LMTV, AND LMTV TRAILER 0005 00  
OPERATION UNDER USUAL CONDITIONS**

---

**Lowering the upper extendable portion of the CBC.** Once all the lifting/locking assemblies are in their stowed positions, the winch assembly must be used to lower the upper extendable portion of the CBC to its fully retracted position.

While positioned in front of the winch assembly, install the ratchet handle **(1)** (if not already in place) by engaging the male portion **(2)** of the handle with the female socket **(3)** located just inside the round opening **(4)** in the winch cover **(5)**.

Move the lever **(6)** on the back of the ratchet handle **(1)** to the left so that the handle engages positively when turned in a counter-clockwise direction.



---

**WARNING**

---

Be sure to position the lever on the back of the ratchet handle so as to LOWER the upper portion of the CBC. If the CBC is moving upward while turning the ratchet **STOP IMMEDIATELY**. Extending the upper portion of the CBC past the warning mark will cause undue stress to the cables and may cause the cables to snap and the upper section of the CBC to drop. Failure to stop at the warning mark when extending the CBC may result in severe injury.

Do not enter the interior of the CBC while in the process of lowering the upper section. Personnel should be positioned outside the CBC and reach into the personnel door opening to operate the winch. Standing inside the CBC while the upper section is being lowered may result in severe injury.

**CAUTION**

Be sure to return the lower roof access step to its upright, stowed position prior to retracting the CBC. Failure to stow the lower roof access step will cause damage to the upper section and the step as the upper section is lowered.

Begin turning the ratchet handle **(1)** in a counter-clockwise direction until the upper extendable section **(7)** of the CBC begins to lower. As the upper section lowers, it will be necessary to assume a crouched position.

Continue to lower the upper portion of the CBC until it stops and the underside of the roof **(8)** is just above the upper edge **(9)** of the lower section.

When the upper portion of the CBC has been lowered completely, remove the ratchet handle **(1)** (if desired) and stow in a protected location.

Exit the the personnel door opening. Close and latch the remaining upper section of the personnel door.

**CARGO BED COVER (CBC), TYPE III, 2 1/2 T CARGO TRUCK, LMTV, AND LMTV TRAILER 0005 00  
OPERATION UNDER USUAL CONDITIONS**

The Cargo Bed Cover is now in its fully retracted position.

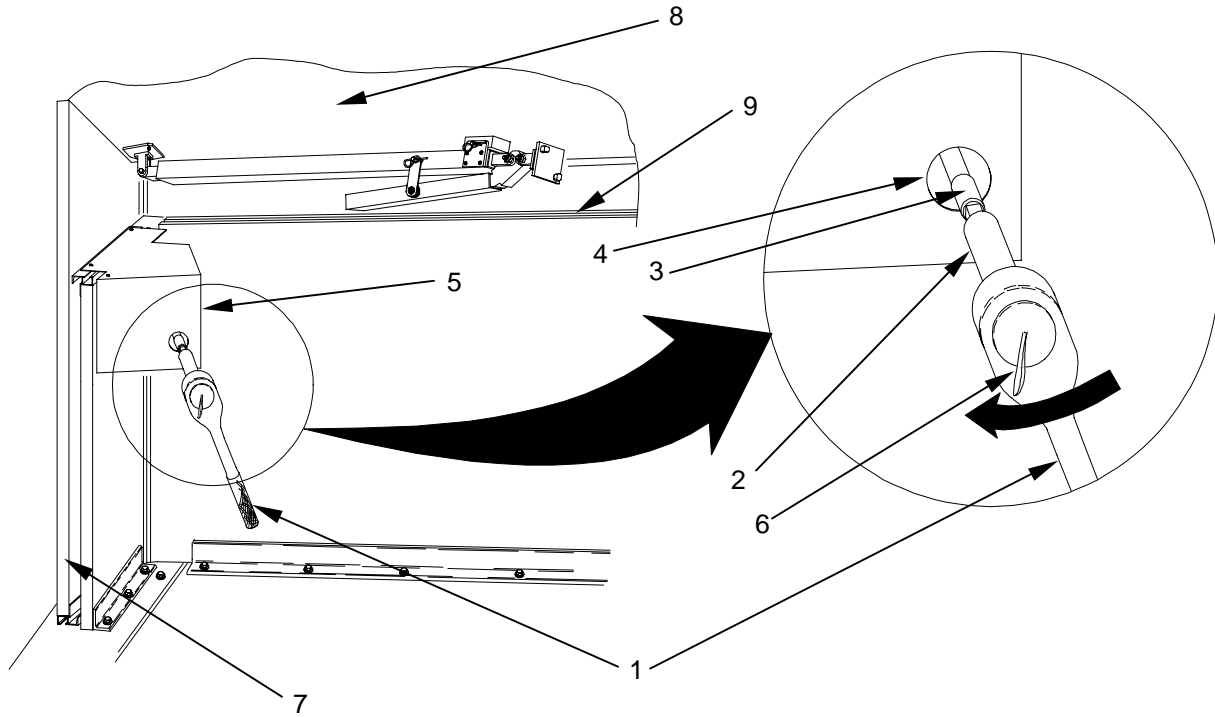

---

**CARGO BED COVER (CBC), TYPE III, 2 1/2 T CARGO TRUCK, LMTV, AND LMTV TRAILER 0005 00  
OPERATION UNDER USUAL CONDITIONS**

---

**PREPARATION FOR MOVEMENT**

When preparing to move from one field location to another for continued operation, the Cargo Bed Cover can be left installed on the vehicle. It may be left in either the extended or retracted position.

If the CBC is in the extended position prior to movement, any cables entering the power and signal line ports on the sidewalls of the CBC should be removed and the ports covered as detailed earlier in this work package.

The personnel door should be closed and locked securely.

The ladder should be stowed and secured in place at the rear of the vehicle.

**PREPARATION FOR STORAGE**

The Cargo Bed Cover may be stored on or off of the vehicle. Prior to going into storage, all "After Operation" PMCS procedures as outlined in WP 0012 should be completed. Reasonable steps should be taken to provide a dry place protected from environmental extremes such as dust and rain for storage.

If the CBC will be stored off vehicle, it should be left in its fully extended position with the door closed and locked.

If any CBC assemblies are in need of repair, the appropriate requests should be forwarded to Unit or Direct Support maintenance as required.

All lubrication should be performed as detailed in WP 0007 entitled Lubrication Requirements prior to storage.



---

**CARGO BED COVER (CBC), TYPE III, 2 1/2 T CARGO TRUCK, LMTV, AND LMTV TRAILER 0006 00  
OPERATION UNDER UNUSUAL CONDITIONS**

---

## **OPERATION IN UNUSUAL ENVIRONMENT OR WEATHER CONDITIONS**

### **GENERAL**

Refer to Operation Under Usual Conditions (WP 0005), for specific operating instructions, and use this work package for further instruction if operating the Cargo Bed Cover in unusual conditions. Read all sections which apply to the conditions to which the CBC will be exposed.

### **CAUTION**

If excessive sand, dust, wind, or water enters the CBC during unusual conditions, refer to WP 0013 to reapply RTV sealant.

### **OPERATION IN DUSTY OR SANDY CONDITIONS**

When using the CBC in sandy or dusty conditions it may be necessary to clean the exterior and interior of the CBC more frequently to prevent sand or dust from getting into the CBC lifting mechanism as well as to protect the payload from debris.

It may be necessary to clean the air filter assembly more often. Check the condition of the air filter more frequently and clean as necessary. Replace the air filter if it is not possible to clean it sufficiently to ensure proper air flow.

### **OPERATION IN SNOWY OR SNOW-COVERED CONDITIONS**

### **CAUTION**

Any excess snow or ice should be cleared from the roof, side walls, and personnel door hinges of the Cargo Bed Cover before the CBC is extended or retracted. Excess snow or ice will increase the weight of the upper section of the CBC and place excessive strain on the lifting/lowering components.

No attempt should be made to raise or lower the CBC until all excess snow and ice have been removed.

---

**CARGO BED COVER (CBC), TYPE III, 2 1/2 T CARGO TRUCK, LMTV, AND LMTV TRAILER 0006 00  
OPERATION UNDER UNUSUAL CONDITIONS**

---

**NBC DECONTAMINATION PROCEDURES**

When the CBC is subjected to NBC (Nuclear, Biological, Chemical) contamination, perform operational decontamination procedures in accordance with FM 3-5, until a thorough DECON (Decontamination) can be performed.



**NOTE**

During thorough DECON and reconstitution efforts, rubber/foam gaskets, adhesive sealants, and wire rope cables may need to be replaced and should be considered in logistics planning.

**CARGO BED COVER (CBC), TYPE III, 2 1/2 T CARGO TRUCK, LMTV, AND LMTV TRAILER 0007 00  
OPERATOR LUBRICATION AND SERVICE PARTS INFORMATION**

**LUBRICATION REQUIREMENTS**

The upper door hinges **(1)** of the personnel door should be lubricated with a lithium based grease every 3 months or if there is any resistance to free and easy movement of the door or if the door squeaks when opened or closed. Each hinge is equipped with a grease fitting for this purpose.

The winch assembly should be lubricated every 3 months. To lubricate the winch assembly, remove the winch assembly cover. Put a small amount of grease on the worm gear/gear contact area **(3)**.

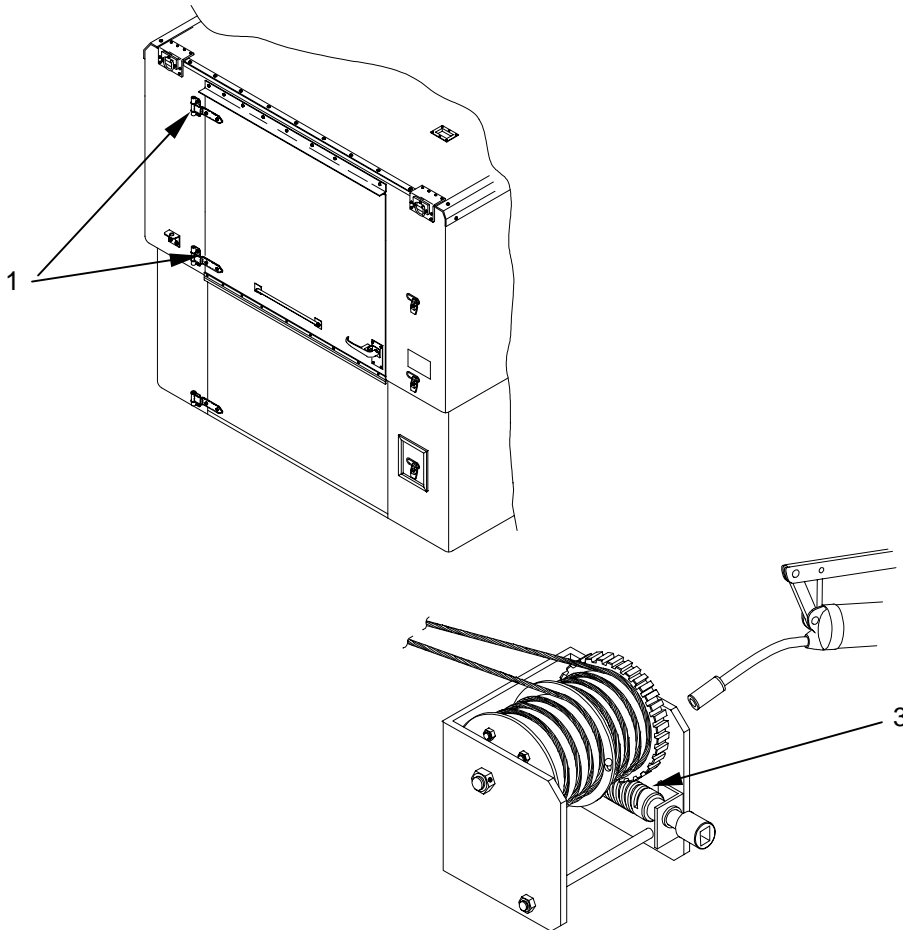

**SERVICE PARTS OVERPACK**

There will not be any service overpack during initial fielding of the Cargo Bed Cover.





TM 10-5411-233-13&P

**CHAPTER 3**

**TROUBLESHOOTING PROCEDURES**  
**FOR**  
**CARGO BED COVER (CBC), TYPE III,**  
**2 1/2 T CARGO TRUCK, LMTV, AND LMTV TRAILER**



---

**CARGO BED COVER (CBC), TYPE III, 2 1/2 T CARGO TRUCK, LMTV, AND LMTV TRAILER 0008 00  
OPERATOR MALFUNCTION SYMPTOM INDEX**

---

**INTRODUCTION TO TROUBLESHOOTING.**

The Malfunction Symptom Index lists common malfunctions that may occur during the inspection and operation of the CBC.

Find the malfunction the CBC is experiencing in the index and go to the given troubleshooting procedure in the following pages.

These charts cannot list all malfunctions that may occur, all tests or all inspections needed to find the fault, nor all actions required to correct the fault. If your malfunction is not listed in, or is not correctable through this troubleshooting index, notify Unit Maintenance.

**MALFUNCTION SYMPTOM INDEX**

<b>Malfunction or Symptom</b>	<b>Refer to Troubleshooting Procedure</b>
Door misalignment	1
Striking Rod Misalignment	2



---

**CARGO BED COVER (CBC), TYPE III, 2 1/2 T CARGO TRUCK, LMTV, AND LMTV TRAILER 0009 00  
TROUBLESHOOTING PROCEDURES**

---

**TROUBLESHOOTING PROCEDURES**

The troubleshooting procedures contain tables that list possible malfunctions, the tests or inspections to perform, and the corrective action required to return the CBC to normal operation. Perform the steps in the order they appear in the tables.

Each procedure is headed by an initial setup. This setup outlines what is needed as well as certain conditions which must be met before starting the task.

**DO NOT START THE TASK UNTIL:**

- You understand the task
- You understand what you are to do
- You understand what is needed to do the work
- You have the things you need

This manual cannot list all malfunctions that may occur, or all tests or inspections and corrective actions. If a malfunction is not listed or is not corrected by listed corrective actions, notify unit maintenance.

TM 10-5411-233-13&P

**CARGO BED COVER (CBC), TYPE III, 2 1/2 T CARGO TRUCK, LMTV, AND LMTV TRAILER 0009 00  
TROUBLESHOOTING PROCEDURES**

**THIS PROCEDURE COVERS:**

Door Misalignment

**INITIAL SETUP:**

Maintenance Level  
Operator

Materials/Parts  
None

<b>Malfunction</b>	<b>Symptom</b>	<b>Corrective Action</b>
Door will not close properly.	Gaps can be seen around the door or door binds on closing.	Check that lower door panel mates to upper door panel and that the tongue and groove assembly mates correctly.  Be sure to tighten the three hand knobs securely.

**CARGO BED COVER (CBC), TYPE III, 2 1/2 T CARGO TRUCK, LMTV, AND LMTV TRAILER 0009 00  
TROUBLESHOOTING PROCEDURES**

**THIS PROCEDURE COVERS:**  
Door Strike Rod Misalignment

**INITIAL SETUP:**

Maintenance Level  
Operator

Materials/Parts  
None

<b>Malfunction</b>	<b>Symptom</b>	<b>Corrective Action</b>
Door latch will not engage properly.	Strike rod does not engage in hole in threshold.	<p>Ensure that the door strike rod is installed correctly and passes through the door rod guides on the personnel door.</p> <p>Ensure that all hairpin cotters are installed.</p> <p>Ensure that bolts on both door hinges are tightened securely.</p> <p>Check that lower door panel mates to upper door panel and that the tongue and groove assembly mates correctly.</p> <p>Be sure to tighten the three hand knobs securely.</p>

**END OF WORK PACKAGE**





TM 10-5411-233-13&P

**CHAPTER 4**

**OPERATOR  
MAINTENANCE INSTRUCTIONS  
FOR  
CARGO BED COVER (CBC), TYPE III,  
2 1/2 T CARGO TRUCK, LMTV, AND LMTV TRAILER**



---

**CARGO BED COVER (CBC), TYPE III, 2 1/2 T CARGO TRUCK, LMTV, AND LMTV TRAILER 0010 00  
SERVICE UPON RECEIPT**

---

**SERVICE UPON RECEIPT**

**THIS SECTION COVERS:**

Installation

---

**INITIAL SETUP**

CBC on shipping pallet in position near vehicle

**Maintenance Level**

**Materials/Parts**

Unit

**Tools and Special Tools**

General Mechanic Tool Kit (WP 0041, Table 2, Item 1)

---

**GENERAL**

The Cargo Bed Cover is shipped mounted to a modified pallet that must be removed prior to installation. The Unit Maintenance technician should inspect the equipment before it is used. Following is a list of functions which must be performed upon receipt of the CBC:

**Unpacking.** Before installation and use, the Cargo Bed Cover must be removed from its packing pallet and cleaned of packing material and other foreign debris. The CBC should be serviced in accordance with PMCS Table 1, WP 0012.

**Inspection.** The equipment must be inspected for damage incurred during shipment. If the equipment has been damaged in shipment, report the damage on SF 364, Report of Discrepancy.

**Packing list verification.** Check the equipment against the packing list, located inside the box containing the mounting kit, to see if the shipment is complete. Report all discrepancies in accordance with DA Pam 738-750.

**Pre-operation services.** Service any damaged equipment, as necessary, using Unit Maintenance procedures in Chapter 5 to restore equipment to operable condition.

**REMOVING THE CARGO BED COVER FROM ITS SHIPPING PALLET**

The Cargo Bed Cover is shipped wrapped in plastic and mounted to a modified shipping pallet **(1)** using 8 lag screws and washers **(2)**.

Before separating the CBC from its shipping pallet **(1)**, remove all protective plastic wrap. Slit the plastic with a utility knife in several locations and remove it from the CBC.

If the CBC is shipped in a retracted condition, the CBC must be extended to its operational position as outlined in the section of WP 0005 entitled EXTENDING THE CARGO BED COVER TO AN OPERATIONAL POSITION, prior to removing the lag screws and washers **(2)**. Extending the CBC to its operational position will improve access to the lag screws and put the CBC in the condition necessary to lift it onto the vehicle using the Lift Rings.

Once the CBC is in its fully extended position, remove all 8 lag screws and washers **(2)**. There are two lag screws in the carrier mounting angles **(3)** on each of the four walls of the CBC. These lag screws hold the CBC to the shipping palette **(1)**.

If a mounting kit **(4)** has been provided with the CBC, it will be necessary to cut the shipping straps **(5)**

**CARGO BED COVER (CBC), TYPE III, 2 1/2 T CARGO TRUCK, LMTV, AND LMTV TRAILER 0010 00  
SERVICE UPON RECEIPT**

prior to removing the mounting kit container from the shipping palette (1).

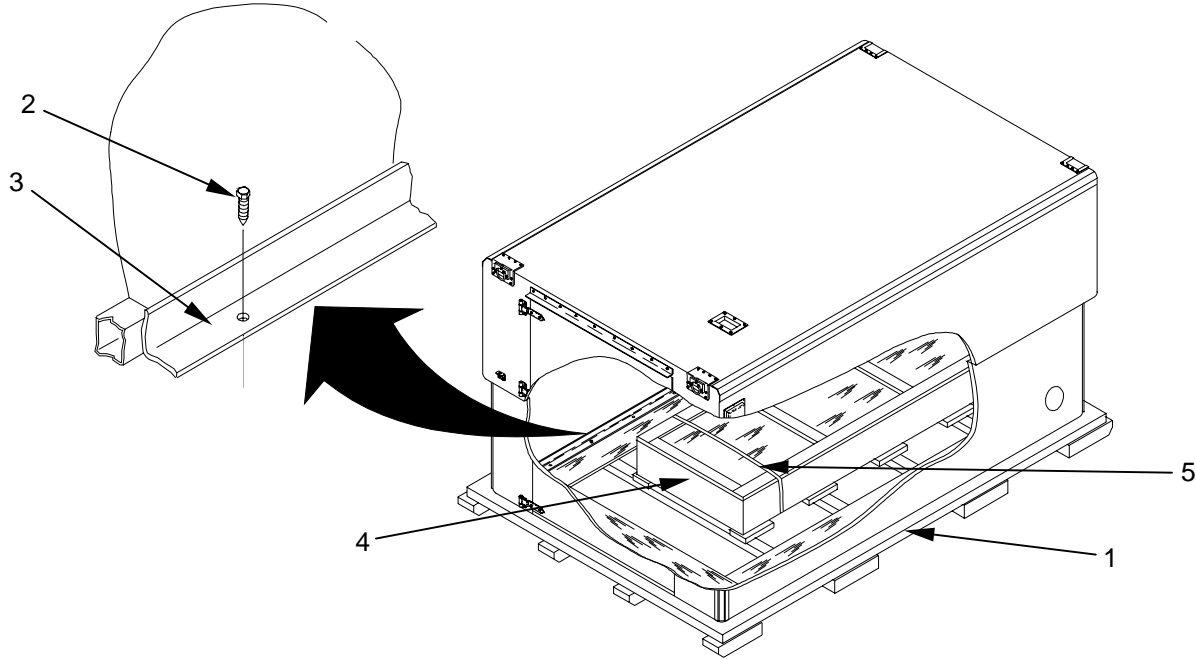

**INSTALLATION OF MOUNTING KITS**

The Cargo Bed Cover is designed to be used on three different types of vehicles, the M35A2, 2 1/2 T Cargo Truck, the M1078, 2 1/2 T LMTV, and the M1082, 2 1/2 T LMTV Trailer.

Each type of vehicle requires that a different mounting kit be installed **BEFORE** the CBC can be mounted.

Refer to the table below to determine what mounting kit is required for each vehicle type. Also included in the table is a reference to the Unit Maintenance work package that describes the installation of that particular mounting kit.

The M35A2, 2 1/2 T Cargo Truck also requires the application of a Ladder Installation Kit. The Ladder installation may be applied before or after the installation of the CBC onto the M35A2 Cargo Truck. The M1078, 2 1/2 T LMTV and the M1082, 2 1/2 T LMTV Trailer do not require the installation of a ladder.

Refer to WP 0016 entitled "LADDER INSTALLATION" for complete information on the installation of the ladder assembly on the M35A2, 2 1/2 T Cargo Truck.

Table 1. Vehicle Type and Mounting Kit Reference

Vehicle Type	Mounting Kit	TM Work Package Describing Installation
M35A2, 2 1/2 T Cargo Truck	17-1-0050-1	WP 0013
M1078, 2 1/2 T LMTV	17-1-0221-1	WP 0014
M1082, 2 1/2 T LMTV Trailer	17-1-0222-1	WP 0015

**END OF WORK PACKAGE**

---

**CARGO BED COVER (CBC), TYPE III, 2 1/2 T CARGO TRUCK, LMTV, AND LMTV TRAILER 0011 00  
OPERATOR MAINTENANCE**

---

**THIS SECTION COVERS:**

Operator Maintenance

---

**INITIAL SETUP**

CBC in extended and locked position

**Maintenance Level**

Operator

---

**INTRODUCTION**

This section contains Operator Maintenance applicable to the CBC as authorized by the Maintenance Allocation Chart (MAC) in WP 0041 of this manual.

All maintenance procedures in this section can be performed by one person unless otherwise indicated.

Read all **WARNING's**, **CAUTION's**, and **NOTE's** carefully before attempting the procedures. This includes the warnings at the front of this manual.

Each maintenance item will include a heading which lists the action to be taken, the tools and parts/materials required, and the condition the equipment must be in to perform the action.

Operator Maintenance of the CBC is limited to those tasks outlined in WP 0012 entitled Preventive Maintenance Checks and Services.

**END OF WORK PACKAGE**



---

**CARGO BED COVER (CBC), TYPE III, 2 1/2 T CARGO TRUCK, LMTV, AND LMTV TRAILER 0012 00  
PREVENTIVE MAINTENANCE CHECKS AND SERVICES (PMCS)**

---

**THIS SECTION COVERS:**

Introduction, PMCS Procedures

---

**INITIAL SETUP:**

**Maintenance Level**

Operator

**Tools and Special Tools**

**Materials/Parts**

Rags (WP 0055, Table 1, Item 6)

Detergent (WP 0055, Table 1, Item 7)

---

**INTRODUCTION**

Preventive Maintenance Checks and Services (PMCS) are performed to keep the Cargo Bed Cover (CBC) and its associated equipment in good operating condition. The checks are used to find, correct, or report problems. PMCS are done every day the CBC is operated, using the PMCS table. Pay attention to WARNING and CAUTION statements. A WARNING means someone could be hurt. A CAUTION means equipment could be damaged. Operators are to perform the PMCS tasks, keeping in mind the following guidelines:

Before you begin using the CBC, do **Before PMCS**

During use of the CBC, do **During PMCS**

After using the CBC, do **After PMCS**

Once a week, do **Weekly PMCS** if the CBC has been in use

Do **Monthly PMCS** once a month if the CBC has been in use

If you find something wrong when performing PMCS, fix it using troubleshooting and/or maintenance procedures.

The right-hand column of the PMCS table lists conditions that make the CBC not fully mission capable. Write up the faults that cannot be repaired on DA Form 2404 for unit maintenance. For further information on how to use this form, see DA PAM 738-750.

If tools that are required to perform PMCS are not listed in procedures, notify your superior.

**INSPECTION**

Look for signs of trouble. Senses help here. You can feel, smell, hear, or see many problems that can be eliminated before they get worse. Inspect to see if items are in good condition. Are components correctly installed and secured? Is any damage to the frame or components visible? Correct any faults or notify unit maintenance.

---

**CARGO BED COVER (CBC), TYPE III, 2 1/2 T CARGO TRUCK, LMTV, AND LMTV TRAILER 0012 00  
PREVENTIVE MAINTENANCE CHECKS AND SERVICES (PMCS)**

---

There are some common items to check on the CBC and associated equipment. These include the following:

- Proper operation of the lifting/locking assemblies
- Proper operation of the winch assembly
- Proper operation of the personnel door
- Ensure that the ventilation ports are clean and free of any debris

### **LUBRICATION SERVICE INTERVALS**

Lubrication requirements for the CBC are outlined in WP 0007.

### **CLEANING**

Proper cleaning of the CBC and components is an integral part of maintenance. It will help prevent possible problems in the future, so make it a habit to clean the CBC inside and out whenever necessary. Both the CBC interior and exterior can be cleaned with a rag dampened with soap and water.



**TM 10-5411-233-13&P**

**CARGO BED COVER (CBC), TYPE III, 2 1/2 T CARGO TRUCK, LMTV, AND LMTV TRAILER 0012 00  
PREVENTIVE MAINTENANCE CHECKS AND SERVICES (PMCS)**

**THIS SECTION COVERS:**

Before Operation PMCS Checks and Services

**INITIAL SETUP:**

CBC in extended and locked position

**Maintenance Level**

Operator

Table 1. Preventive Maintenance Checks and Services (PMCS) for Cargo Bed Cover

ITEM NO.	INTERVAL	ITEM TO BE CHECKED OR SERVICED	PROCEDURE	EQUIPMENT NOT READY/ AVAILABLE IF:
1	Before	Upper Door Assembly	Ensure that upper (1) door section is properly engaged. Verify that the three twist knobs (2) securing the upper (1) and lower (3) door sections are tightened securely. Verify that hairpin cotter (4) in door latch mechanism (5) is installed and undamaged. Verify that fabric pull strap (6) is undamaged. Check for free and easy operation of Personnel Door (7), latch mechanism (5), and door hold-open device (8). Verify that door latch rods (18) do not have excessive wear at the point where they pass through the rod guides (19).	Personnel door does not open or close properly. Door latch mechanism does not operate properly or hairpin cotter is missing. Fabric pull strap is damaged or missing. Door hold-open device is damaged or does not operate properly. Ends of door latch rods are excessively worn.
2	Before	Lower Door Assembly	Ensure that the lower door section (3) is properly engaged and secured to the upper door section (1).	Lower door section does not attach securely to the upper door section.
3	Before	Upper and Lower Steps	Check for free and easy operation of roof access folding steps (9). Ensure that the folding steps operate properly. Check for any cracks or breaks in the folding steps including loose or missing attaching hardware (10) that would create an unsafe condition.	Roof access steps are cracked, broken, or otherwise damaged. Roof access step hardware missing.
4	Before	Lift Rings	Check for free and easy operation of Lift Rings (11). Ensure that the lift rings operate properly. Check for any cracks or breaks in the assembly that would create an unsafe condition. Check for any loose or missing attaching hardware (12) that would create an unsafe condition.	Lift rings cracked broken or otherwise damaged. Lifting ring hardware missing.
5	Before	Lifting/Locking Assemblies	Inspect the condition of the lifting/locking assemblies (13). If the CBC is in the height extended mode, ensure that the lifting/locking assemblies are in their vertical and locked position.	Lifting/locking assembly does not swing into position properly. Locking mechanism does not engage properly. Lifting/locking assembly does not stow properly.
6	Before	Handhold	Ensure that the roof access step handhold attaching hardware (14) is secure and not missing.	Roof access handhold attaching hardware missing or not secure.
7	Before	Ventilation Port	Make sure that the ventilation ports (15) are not blocked. Inspect the air filter (16) and clean if necessary.	Ventilation ports blocked or air filter dirty.
8	Before	Cabling	Inspect the visible portion of the cabling in the upper section cable channel. Verify that the winch cabling (17) has not been damaged, frayed, or abraded in any way.	Cable damaged, frayed, or abraded.
9	Before	Carrier Mounting Bolts	Ensure that all carrier mounting hardware (18) is securely tightened. Ensure that all vehicle mounting kit mounting hardware (19) is tightened securely.	Carrier hardware missing or not secure. Vehicle mounting kit hardware missing or not secure.

**CARGO BED COVER (CBC), TYPE III, 2 1/2 T CARGO TRUCK, LMTV, AND LMTV TRAILER 0012 00  
PREVENTIVE MAINTENANCE CHECKS AND SERVICES (PMCS)**

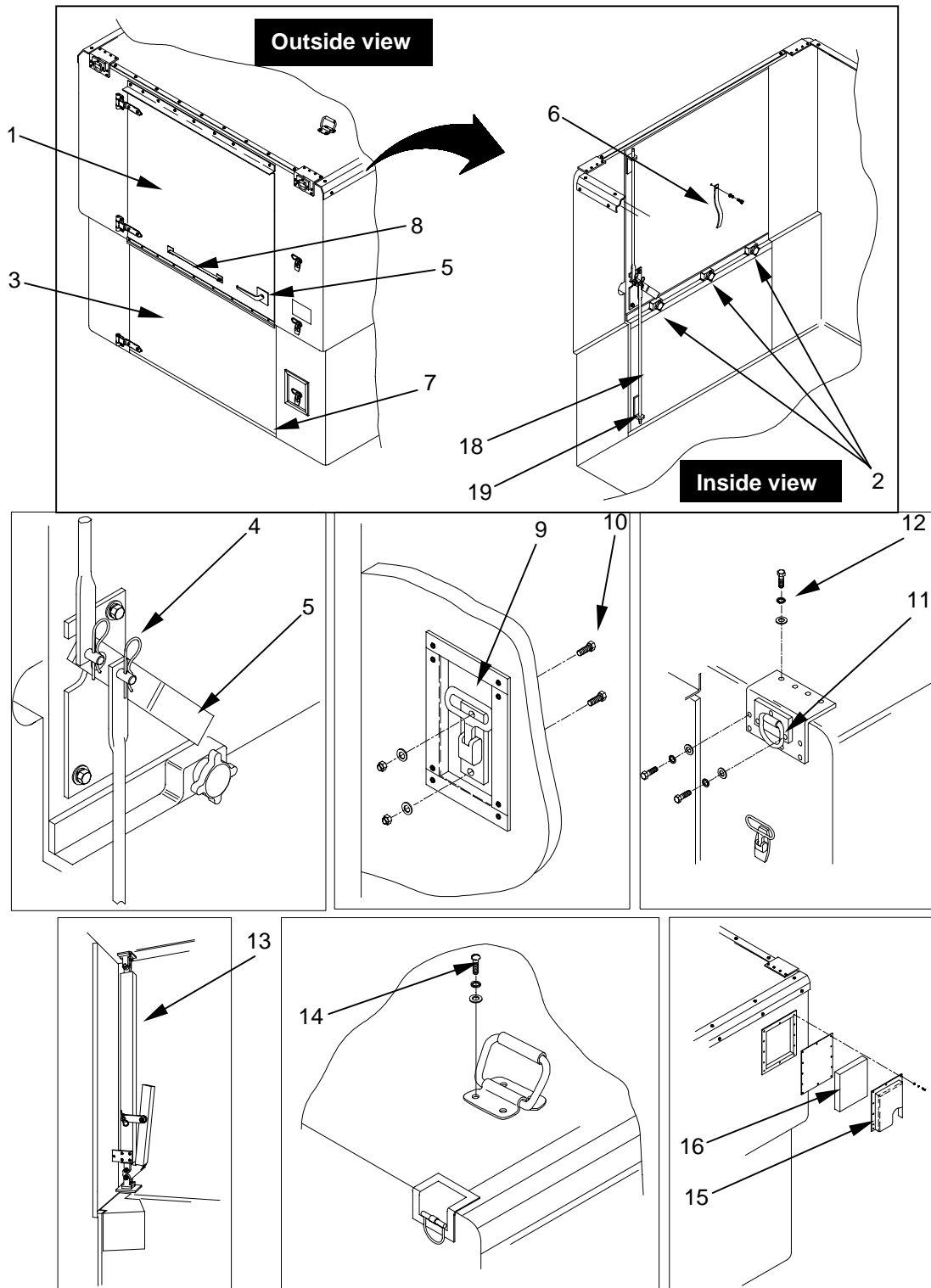

CBC "Before Operation" PMCS

**CARGO BED COVER (CBC), TYPE III, 2 1/2 T CARGO TRUCK, LMTV, AND LMTV TRAILER 0012 00  
PREVENTIVE MAINTENANCE CHECKS AND SERVICES (PMCS)**

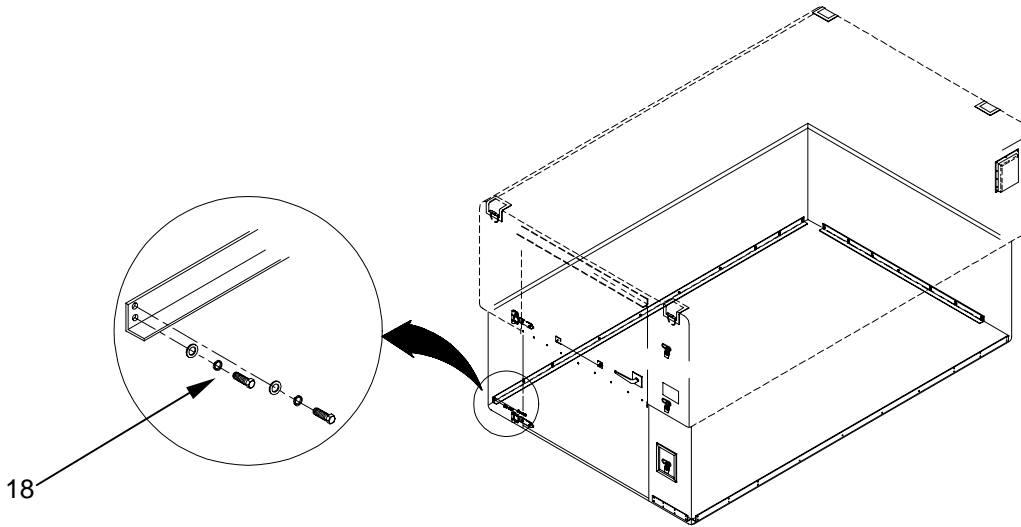
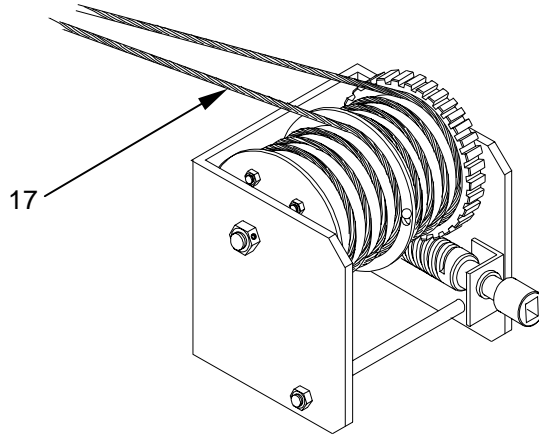

M1078, 2 1/2 T LMTV or M1082, 2 1/2 T LMTV Trailer Mounting Hardware

M35A2, 2 1/2 T Cargo Truck Mounting Hardware

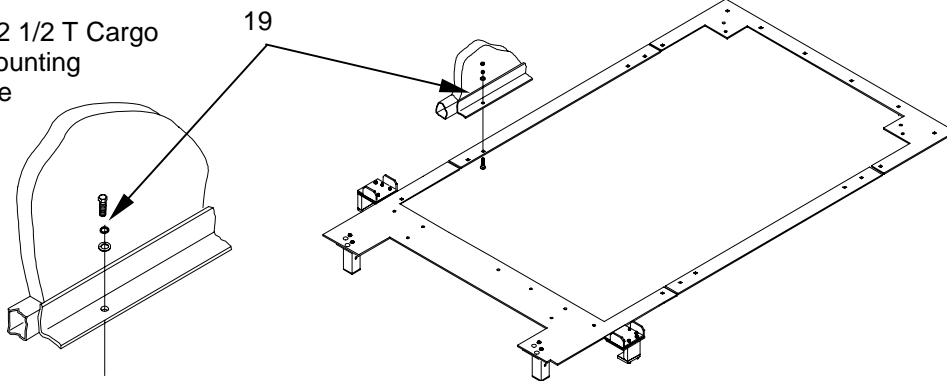

**CARGO BED COVER (CBC), TYPE III, 2 1/2 T CARGO TRUCK, LMTV, AND LMTV TRAILER 0012 00  
PREVENTIVE MAINTENANCE CHECKS AND SERVICES (PMCS)**

**THIS SECTION COVERS:**

During Operation PMCS Checks and Services

**INITIAL SETUP:**

CBC in extended and locked position

**Maintenance Level**

Operator

Table 1. Preventive Maintenance Checks and Services (PMCS) for Cargo Bed Cover - continued

ITEM NO.	INTERVAL	ITEM TO BE CHECKED OR SERVICED	PROCEDURE	EQUIPMENT NOT READY/ AVAILABLE IF:
10	During	Upper Extendable Section	Ensure that the winch mechanism (1) and the upper CBC section (2) operate and rise smoothly. Verify that no unusual effort is required to operate the winch.	Upper section of the CBC does not rise smoothly or the winch assembly appears to be binding.
11	During	Lifting/Locking Assembly	Verify that the lifting/locking assemblies (3) operate smoothly and install in their vertical and locked position.	Lifting/locking assemblies do not swing down or lock properly in their vertical position.

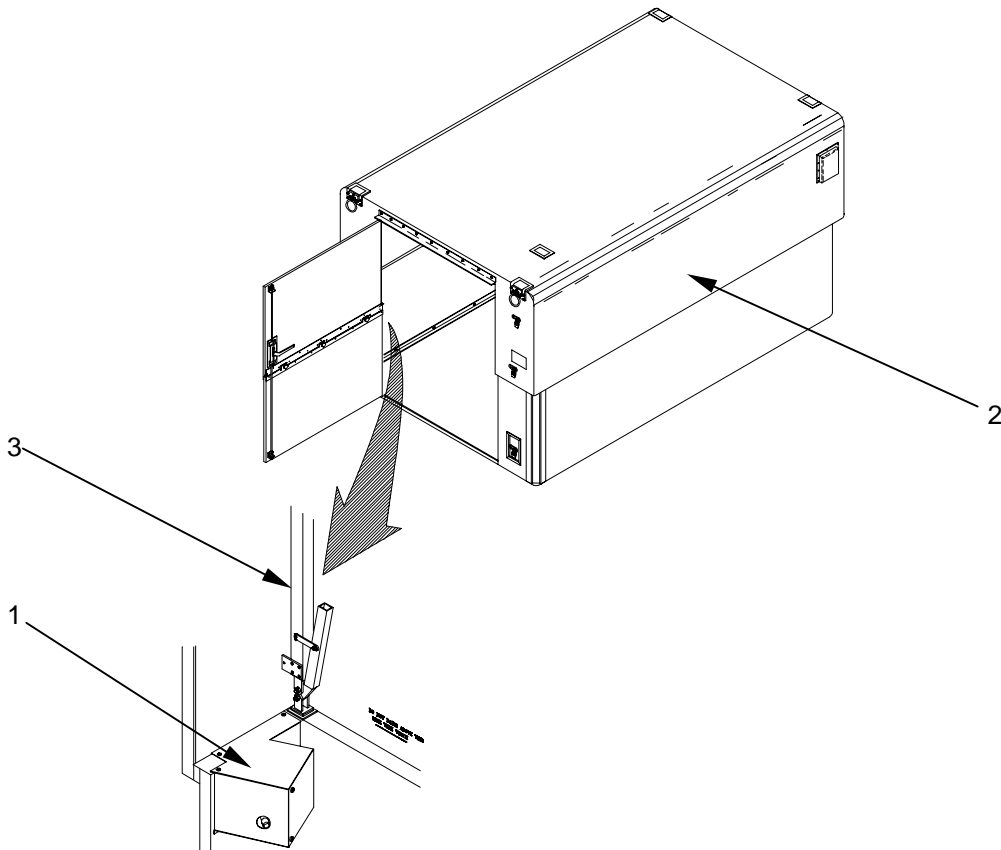

CBC "During Operation" PMCS

**CARGO BED COVER (CBC), TYPE III, 2 1/2 T CARGO TRUCK, LMTV, AND LMTV TRAILER 0012 00  
PREVENTIVE MAINTENANCE CHECKS AND SERVICES (PMCS)**

**THIS SECTION COVERS:**

After Operation PMCS Checks and Services

**INITIAL SETUP:**

CBC in extended and locked position

**Maintenance Level**

Operator

Table 1. Preventive Maintenance Checks and Services (PMCS) for Cargo Bed Cover - continued

ITEM NO.	INTERVAL	ITEM TO BE CHECKED OR SERVICED	PROCEDURE	EQUIPMENT NOT READY/ AVAILABLE IF:
12	After	Winch Assembly	Lubricate winch mechanism (1) in accordance with the lubrication schedule.	Winch mechanism has not been lubricated according to schedule or exhibits evidence of requiring additional lubrication.
13	After	Upper and Lower Personnel Door	Lubricate hinges (2) on the upper and lower sections of the personnel door in accordance with the lubrication schedule.	Door hinges have not been lubricated according to schedule or exhibit evidence of requiring additional lubrication.
14	After	Helicopter Cable Rub Strip	Inspect the condition of the helicopter cable rub strip (3) for burrs or any damage that could cause damage to the helicopter cable during airlift.	Burrs on helicopter rub strip that would abrade or cut helicopter airlift cables
15	After	CBC Interior Surface	Clean the inside (4) of the CBC with a rag and mildly soapy water.	Cleaning is required to ensure normal operation.
16	After	CBC Exterior Surface	Wash the outside of the CBC (5) as necessary.	Cleaning is required to ensure normal operation.

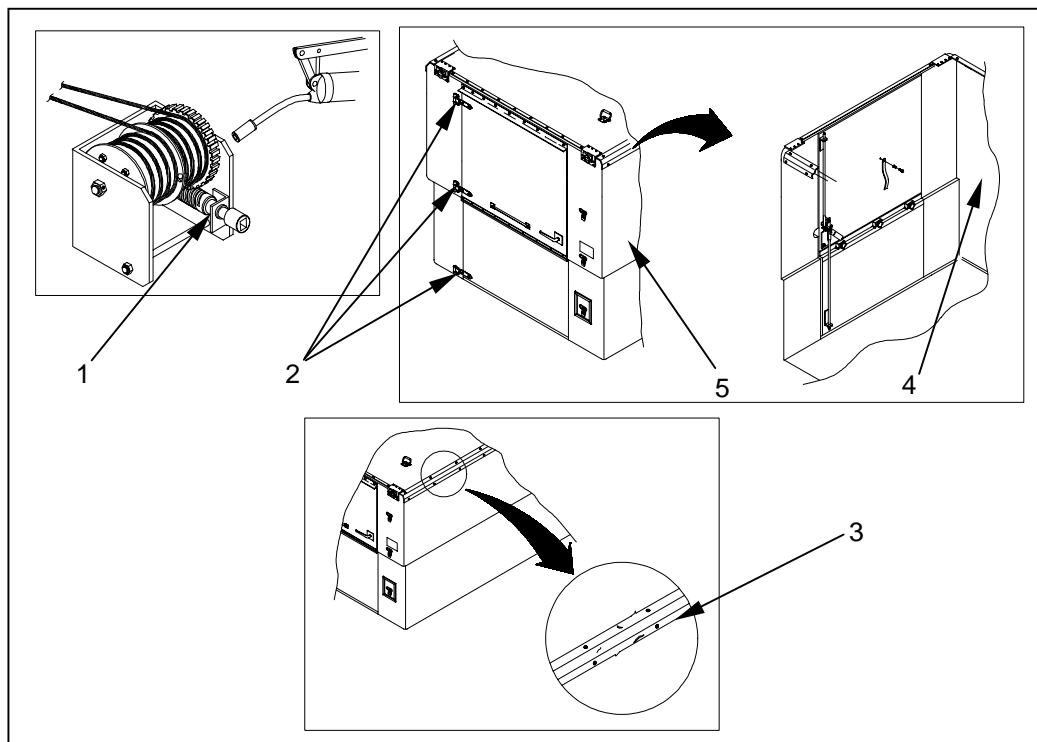

**TM 10-5411-233-13&P**

**CARGO BED COVER (CBC), TYPE III, 2 1/2 T CARGO TRUCK, LMTV, AND LMTV TRAILER 0012 00  
PREVENTIVE MAINTENANCE CHECKS AND SERVICES (PMCS)**

**MANDATORY REPLACEMENT PARTS**

Some parts used on the Cargo Bed Cover should be replaced on a specific schedule regardless of their condition. Under certain environmental conditions, these parts may require replacement sooner than the period stated in the table below.

Table 2. Mandatory Replacement Parts (to be replaced each year of operation\*)

<b>Item No.</b>	<b>Part Number</b>	<b>NSN</b>	<b>Nomenclature</b>	<b>Qty</b>
1	17-1-0042-3	--	Weather Seal**	1
2	17-1-0042-4	--	Weather Seal	1
3	17-1-0215-1	--	Air Filter***	1
4	17-1-0288-1	--	Rain Guard	1
5	17-1-0288-2	--	Rain Guard	1

\* The mandatory replacement period of one year can be extended for CBC's that are, or have been, in storage for extended periods.

\*\* Washing or cleaning weather gaskets/seals/guards in solvent will shorten their useful life. Heavy use may affect the life of the door weather gaskets, and may make replacement sooner than the one year period required.

\*\*\* Using the CBC in heavy dust areas could result in the need to replace the air filter sooner than the one year period. However, the air filter can be cleaned with soap and water, which will lengthen its useful life.

**END OF WORK PACKAGE**

TM 10-5411-233-13&P

**CHAPTER 5**

**UNIT**

**MAINTENANCE INSTRUCTIONS**

**FOR**

**CARGO BED COVER (CBC), TYPE III,**

**2 1/2 T CARGO TRUCK, LMTV, AND LMTV TRAILER**





**CARGO BED COVER (CBC), TYPE III, 2 1/2 T CARGO TRUCK, LMTV, AND LMTV TRAILER 0013 00  
UNIT MAINTENANCE**

**INSTALLATION OF MOUNTING KIT FOR M35A2, 2 1/2 TON CARGO TRUCK**

**THIS SECTION COVERS:**

Installation

**INITIAL SETUP**

Vehicle bed clean and free of debris  
 CBC unpacked as detailed in WP 0010 and  
 positioned on pallet near the vehicle.  
 Mounting Kit unpacked and hardware organized

**Maintenance Level**

Unit

**Tools and Special Tools**

General Mechanic Tool Kit (WP 0041, Table 2, Item 1)

**Materials/Parts**

Light machine oil  
 (WP0055, Table 1, Item 1)  
 Sealant, Type II [RTV] (WP0055, Table  
 1, Item 18)

**GENERAL**

Before the Cargo Bed Cover can be installed on the bed of the M35A2, 2 1/2 T Cargo Truck, the bed surface should be cleared of any foreign matter or other debris that would interfere with the installation process. A mounting kit must be installed to the truck bed that will allow the CBC to be secured to the vehicle.

Unless it is already in an extended position, once the CBC has been separated from its shipping pallet and prepared for installation as outlined in the UNPACKING section of WP 0010, it must be extended to its operational position as outlined in WP 0005 entitled EXTENDING THE CARGO BED COVER TO AN OPERATIONAL POSITION.

**LIFTING THE CBC INTO POSITION ONTO THE VEHICLE BED AND  
 DETERMINING CORRECT MOUNTING LOCATION**



**WARNING**

Do not lift the Cargo Bed Cover in its height retracted (lowered) condition. The CBC must be in its height extended (fully raised) condition prior to using the lift rings for lifting.

When the CBC is in its fully extended position, it must be lifted into position using the four Lift Rings positioned along the fore and aft roof lines of the CBC. The CBC should be lifted into position over the vehicle bed in accordance with the section of WP 0005 entitled HOISTING THE CARGO BED COVER USING THE LIFT RINGS.

TM 10-5411-233-13&P

CARGO BED COVER (CBC), TYPE III, 2 1/2 T CARGO TRUCK, LMTV, AND LMTV TRAILER 0013 00  
UNIT MAINTENANCE

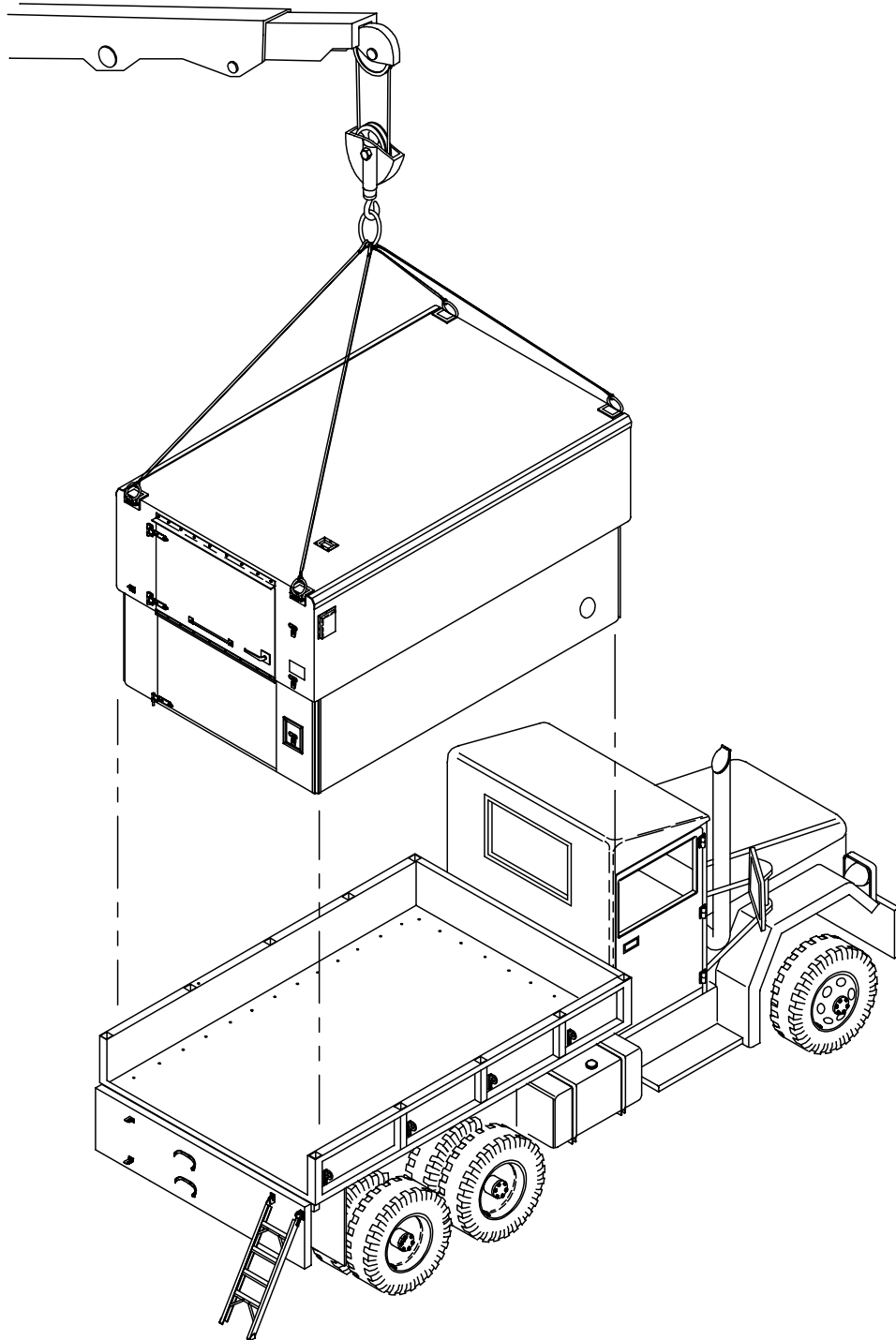

0013 00-2

**CARGO BED COVER (CBC), TYPE III, 2 1/2 T CARGO TRUCK, LMTV, AND LMTV TRAILER 0013 00  
UNIT MAINTENANCE**

To determine the proper mounting position for the CBC on the vehicle bed from front to back, lower the CBC into position on the vehicle bed so that the forward end of the upper section **(1)** is 1.4 ± .13 inches back (3.0 inches ± .13 from the lower section) from the inside front wall of truck bed **(2)** of the vehicle. Do not remove the hoisting sling at this time since it will be necessary to remove the CBC from the vehicle bed in a later step.

To correctly position the CBC with respect to the vehicle bed from left to right, the CBC is centered on the bed of the vehicle by ensuring that the distance from the CBC side walls **(3)** to the outer edge of the vehicle bed **(4)** is equal at all four corners.

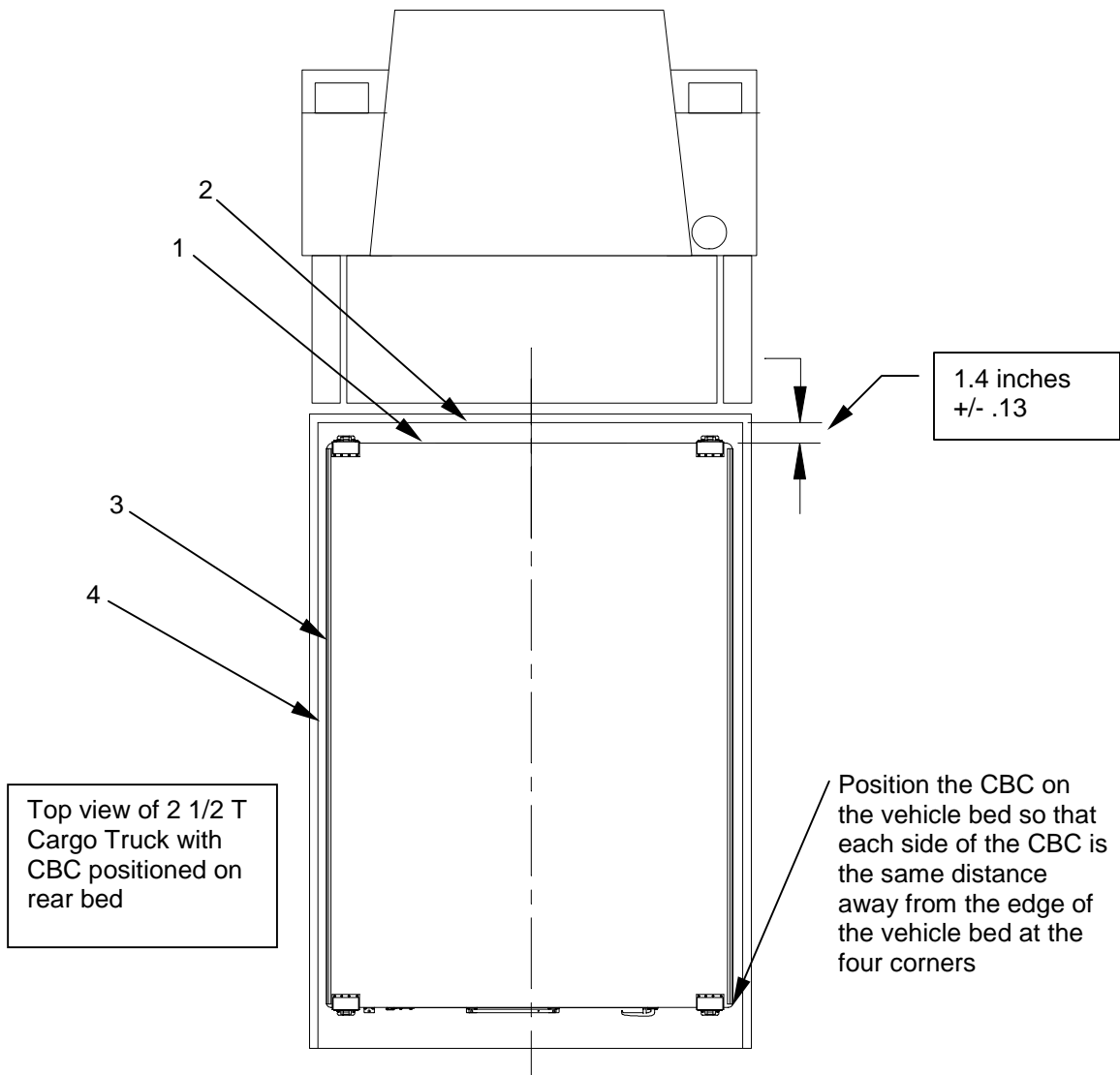

**CARGO BED COVER (CBC), TYPE III, 2 1/2 T CARGO TRUCK, LMTV, AND LMTV TRAILER 0013 00 UNIT MAINTENANCE**

**Identifying gaps between the CBC and the vehicle bed.** Once the CBC is in its correct mounting position on the vehicle bed, the area between the bottom edge of the CBC and the vehicle bed must be inspected in order to detect any gaps that are greater than 1/4 inch. These gaps are typically caused by dents and other irregularities in the surface of the vehicle bed. Weather stripping will be applied in a later step and additional layers will be required in the areas where gaps are identified.

To inspect for gaps greater than 1/4 inch between the CBC and the vehicle bed, use a flashlight and walk around the outside of the CBC at vehicle bed level. Shine the light where the lower edge of the CBC and the vehicle bed meet.

Using chalk, masking tape, or other temporary marking instrument, mark those areas on the CBC where gaps greater than 1/4 inch are present. To inspect for gaps at the front of the CBC, it may be necessary to enter the CBC and conduct the inspection from the inside.

Estimate the width of each gap area in order to determine whether additional 3/16 inch or 1/8 inch weatherstripping will required to properly fill the gap. Make a note of the thickness of additional weatherstripping required with chalk or on a piece of masking tape placed in the area of the gap. In some cases in may be necessary to use some combination of both sizes of weatherstripping in order to properly close the gap.

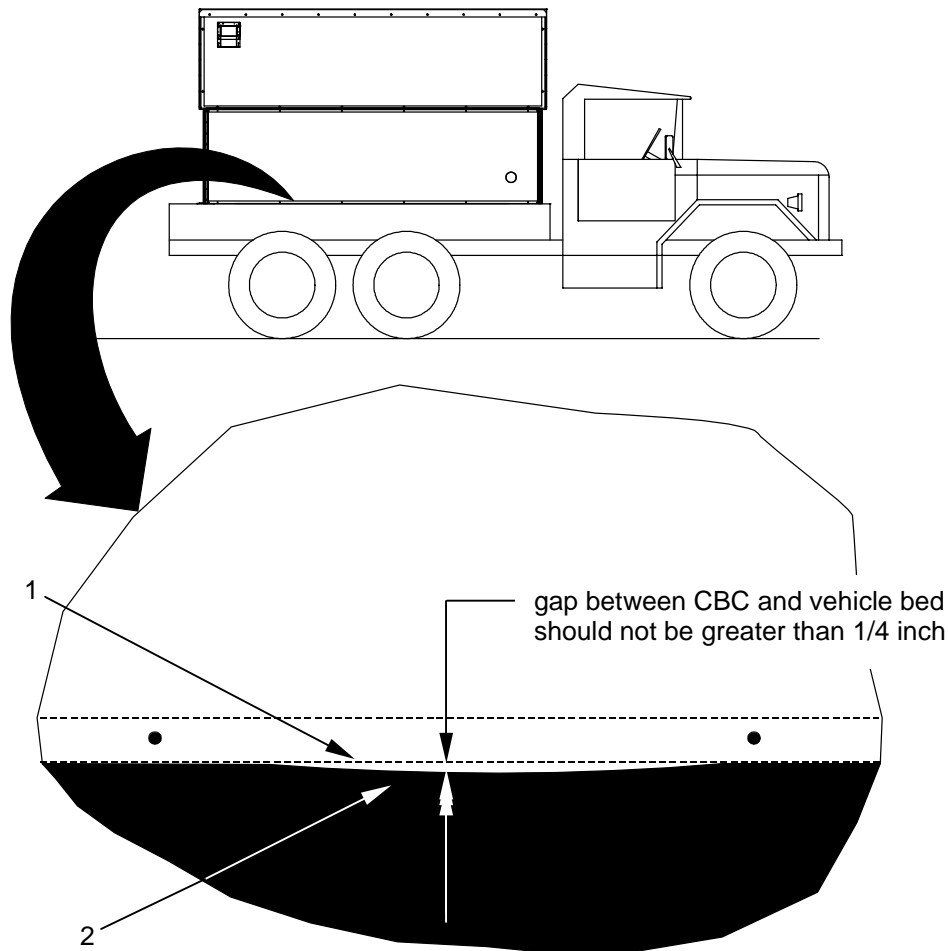

**CARGO BED COVER (CBC), TYPE III, 2 1/2 T CARGO TRUCK, LMTV, AND LMTV TRAILER 0013 00 UNIT MAINTENANCE**

**Marking the location of the carrier mounting angle holes.** The bottom edge of the lower section of the Cargo Bed Cover is attached to the vehicle bed by means of a series of carrier mounting angles (1). These angles and threshold have a total of 27 predrilled mounting holes where only 19 of the holes (2) are used.

To transfer the position of the carrier mounting holes to the vehicle bed, use the 3/8 inch transfer punch (3) supplied with the mounting kit and mark the vehicle bed in 19 places. There are 4 holes each in the carrier mounting angles at the front (4), left (5), and right sides (6) of the CBC. There are two holes in each of the two smaller carrier mounting angles (7) at the rear of the CBC located on either side of the door opening and a total of 3 holes in the threshold.

Once all 19 hole positions have been marked, the CBC can be removed from the vehicle bed and returned to its shipping pallet while the holes are drilled in the vehicle bed and Rivnuts installed.

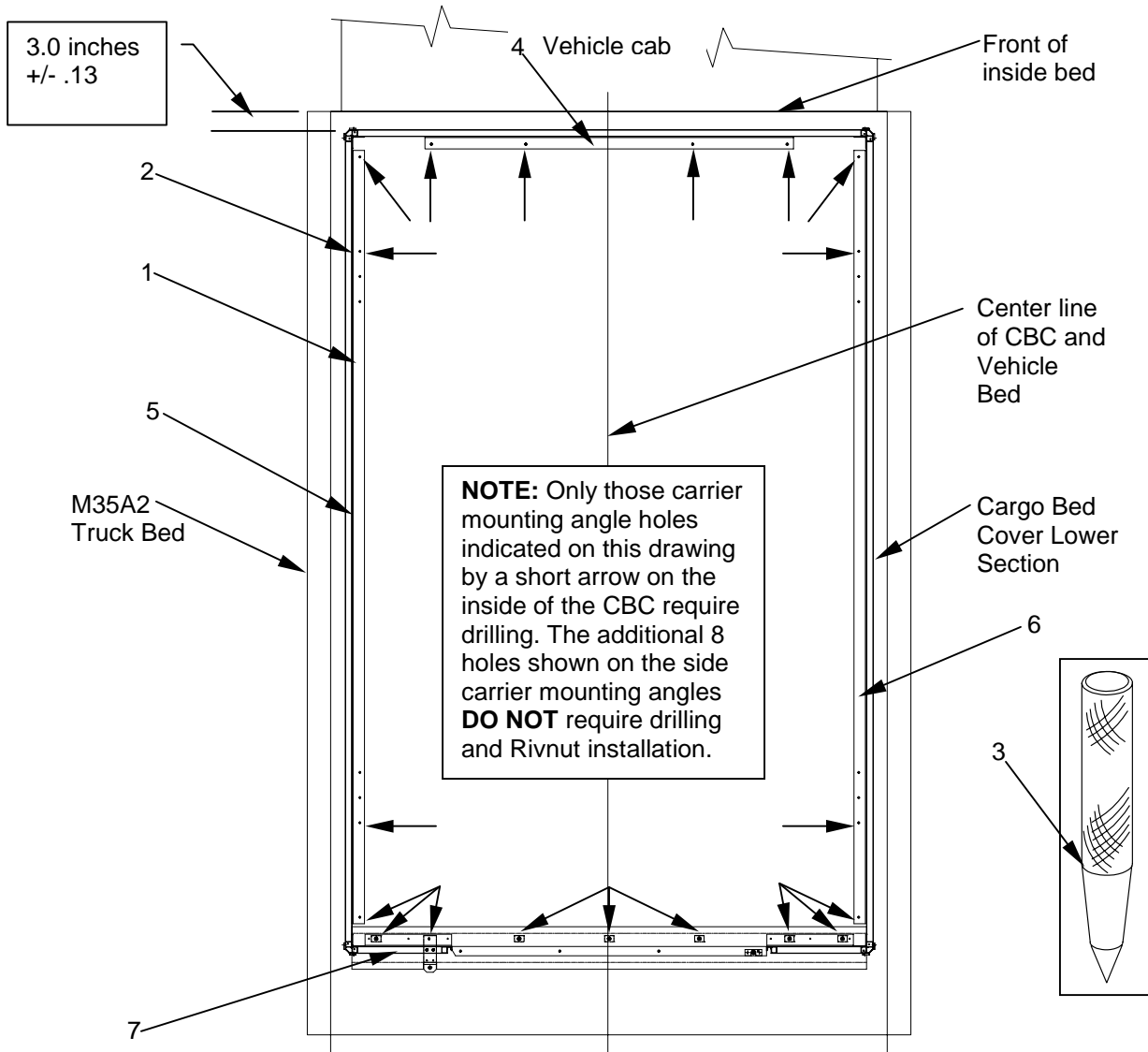

---

**CARGO BED COVER (CBC), TYPE III, 2 1/2 T CARGO TRUCK, LMTV, AND LMTV TRAILER 0013 00  
UNIT MAINTENANCE**

---

**Drilling the mounting holes in the vehicle bed**



**NOTE**

Drilling is made easier by starting with a smaller diameter drill bit. Increase the drill bit diameter in steps until the required diameter is met.

Once the CBC has been removed from the vehicle bed to allow access to the hole positions marked previously, Rivnut installation holes must be drilled at each of the 3/8 inch transfer punch locations (19 total), to their final size using a letter "Z" (.413 inch) diameter drill bit. Make sure that the drill bit is positioned in the center of the punched mark.

**Installing Rivnuts**

**CAUTION**

Always apply anti-sieze lubricant to bolt and screw threads before installation to prevent galling.

During the installation of blind rivet nuts (Rivnuts), the threads inside the Rivnut can sometimes be damaged by the installation tool, and may result in the the bolts and screws binding. If this occurs, run a 5/16-18 UNC tap (included with the mounting kit) into the threaded area. This will clear and straighten the threads, making for easier and faster assembly. Care should be taken using this method since the tap has the ability to remove and/or cross thread existing threads. Be sure to work slowly and deliberately when clearing the threads.

When all holes are drilled, install Rivnuts in each of the 19 installation holes using the hand operated Rivnut installation tool **(1)**, hex (allen) wrench **(2)** (included with installation tool), and 3/4 inch (or 1 1/16 inch depending on header tool used) wrench **(3)** (adjustable, fixed, or box end ratchet type).



**NOTE**

Before using the installation tool, inspect the condition of the jackscrew threads before use. If the tool has been used previously, the jackscrew threads may require a few drops of a light machine oil. If this is the initial use of the tool, no additional lubrication will be required.

To install a Rivnut, thread the Rivnut fastener **(4)** onto the threaded end **(5)** of the installation tool **(1)** included with the mounting kit. Be sure that the end of the installation tool is tight against the head of the fastener.

With the Rivnut **(4)** installed on the installation tool **(1)**, insert the Rivnut into the hole **(6)** previously drilled in the vehicle bed **(7)**.

**CARGO BED COVER (CBC), TYPE III, 2 1/2 T CARGO TRUCK, LMTV, AND LMTV TRAILER 0013 00  
UNIT MAINTENANCE**

Insert the hex wrench (2) into the socket (8) at the top of the installation tool (1). Insert the jaws of the adjustable or fixed wrench (3) on the flat-sided center section (9) of the installation tool (1).

While holding the hex wrench (2) stationary and the installation tool (1) at a right angle to the vehicle bed (7), turn the wrench (3) in a clockwise direction keeping track of the number of turns.

Turn the nut (3) in a clockwise direction until firm resistance indicates that the fastener is completely set. This will be approximately 1-1/2 to 2 turns.

Once the Rivnut is completely set, turn the wrench (3) in a counter-clockwise direction to break its grip with the Rivnut. Remove both wrenches (2,3) from the installation tool (1).

Remove the Rivnut installation tool (1) from the Rivnut by turning the entire tool by hand in a counter-clockwise direction.

Install all remaining Rivnuts in a similar manner.

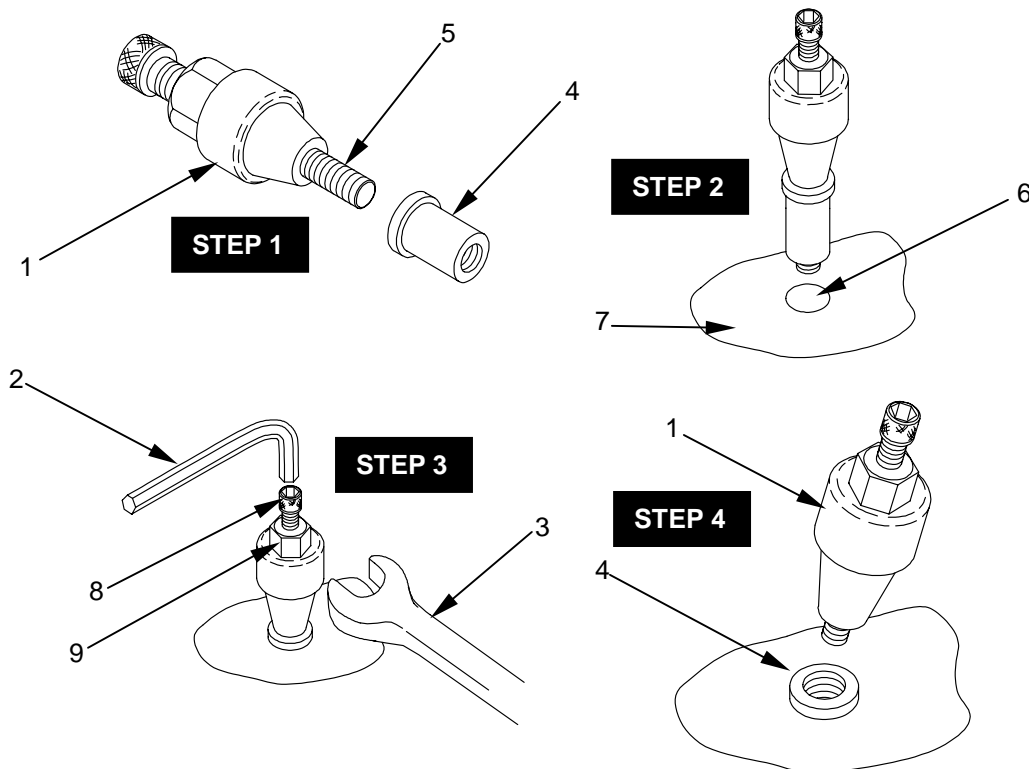

**CARGO BED COVER (CBC), TYPE III, 2 1/2 T CARGO TRUCK, LMTV, AND LMTV TRAILER 0013 00  
UNIT MAINTENANCE**

**INSTALLING WEATHER STRIPPING ON BOTTOM EDGE OF CBC**

Once all Rivnuts have been installed, the CBC can be lifted from its shipping pallet and lowered onto a set of supporting blocks (1) placed between the pallet and the CBC. The blocks are used in order to raise the CBC up off the shipping pallet. This will permit access to the bottom edge of the CBC that contacts the vehicle bed. Two thicknesses of weatherstripping, 3/16 and 1/8 inch are supplied in 50 foot rolls and are included in the mounting kit.

Install the first layer of weather stripping (3/16 inch thick x 1 inch wide) (2) along the bottom edge (3) of the CBC by removing the protective paper (4) backing and pressing the adhesive side (5) of the weather stripping in place on the CBC. Weather stripping is NOT applied to the carrier mounting angles (6), it is applied to the bottom edge (3) of the CBC itself and the underside of the threshold opposite the bottom edge.

Once the first layer (2) of weather stripping is in place, place an additional layer or layers (as required) of weather stripping (1/8 or 3/16 inch thick x 1 inch wide) (7) in those areas identified earlier where gaps greater than 1/4 inch were observed between the CBC and the vehicle bed. Then add a second complete layer of weatherstripping (1/8 inch thick x 1 inch wide) (8) over the first layer (3/16 inch thick x 1 inch wide) (2) and over any additional layers (7) that were added to compensate for gaps.

Once a minimum of 5/16 inch of weather stripping has been installed on the areas of the of the CBC not obscured by the supporting blocks (1), lift the CBC slightly with the hoisting sling, move the supporting blocks (1) to an area where weather stripping has already been installed, and install weatherstripping on the remaining non-weather stripped areas of the CBC as detailed above.

Once all weather stripping has been installed, RTV sealant must applied to the underside of the installed weather stripping as detailed in the next section.

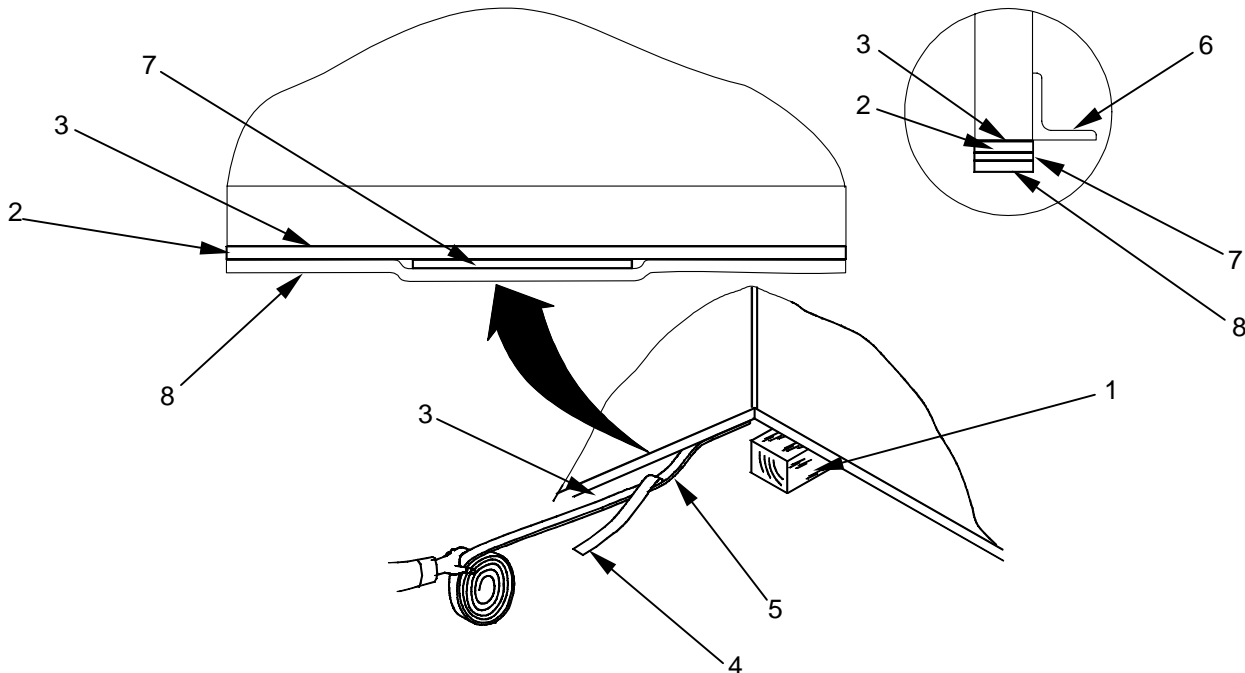



---

**CARGO BED COVER (CBC), TYPE III, 2 1/2 T CARGO TRUCK, LMTV, AND LMTV TRAILER 0013 00  
UNIT MAINTENANCE**

---

**Applying RTV sealant to the weatherstripping surface.**



---

**WARNING**

---

Do not stand inside or directly under the CBC while applying the RTV sealant. Standing under a suspended CBC may result in injury should the hoisting sling fail to support the CBC.



**NOTE**

Sealant should be applied only when the CBC is to be immediately mounted to the vehicle bed. The sealant has a working time of approximately 20 minutes and will start to cure after that time. Installing the CBC on the vehicle after the sealant begins to cure may adversely affect the sealant's ability to properly bond with the vehicle bed.

Once all weather stripping has been applied as detailed in the previous section, a bead of RTV (silicone) sealant must be applied where the weather stripping contacts the vehicle bed.

To apply the RTV sealant, raise the CBC to a comfortable working height using the hoisting sling.

Install the supplied cartridge of sealant into a standard caulking gun. Trim the tip of the cartridge so that a bead approximately 3/16 to 1/4 inch in width can be applied.

Apply a continuous bead of sealant 3/16 to 1/4 inch in width on the surface of the weather stripping along the outer edge. Start at one point on the underside of the CBC and move around the entire perimeter of the CBC applying sealant to all weatherstripping surfaces.

Once sealant has properly applied to all weatherstripping surfaces, the CBC should be lowered into position on the vehicle bed as described in the next section.

**SECURING THE CBC TO THE VEHICLE BED**

Using the hoisting sling, position the CBC on the vehicle bed so that all 19 holes in the carrier mounting angles align with the Rivnuts that were installed earlier.

To prevent smearing of the RTV sealant applied in the previous step, be sure to locate the CBC directly over the holes in the vehicle bed before allowing the CBC to come in contact with the vehicle bed.

**CAUTION**

Always apply anti-sieze lubricant to bolt and screw threads before installation to prevent galling.

Bolt the CBC to the vehicle bed at the 12 locations (**Locations marked “C” on the illustration that follows**) using one 1/4-28 UNF x 1.00 inch long hex head bolt (1), flat washer (3), and lockwasher (2) per hole. The flat washer is placed so that it contacts the mounting angle surface (4). The lockwasher (2) is placed under the head of the bolt (1).

At the four hole locations in the carrier mounting angles on either side of the threshold (**Locations marked “B”**), install one 1/4-28 UNF x 1.25 inch hex head bolt, flat washer, and lockwasher per hole. Install the bolts as described above.

In the remaining three hole locations on the threshold (**Locations marked “A”**), install three pan head screws (5) with lockwasher (6) placed under its head.

Tighten all fasteners securely.

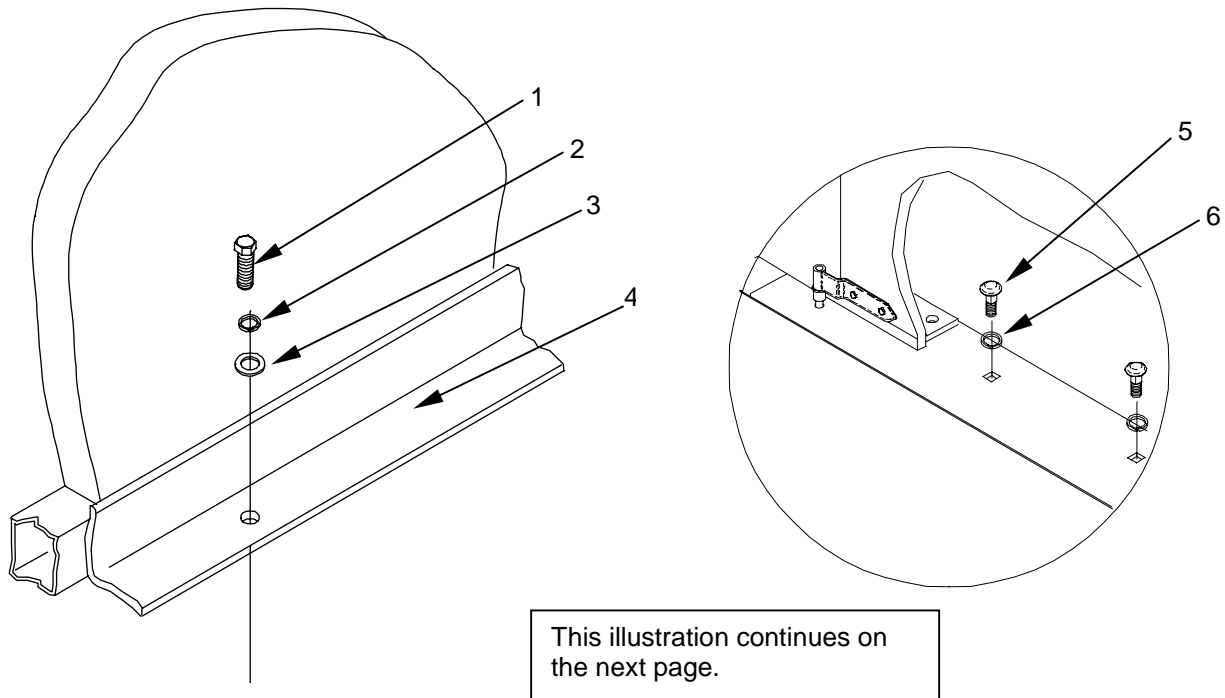

CARGO BED COVER (CBC), TYPE III, 2 1/2 T CARGO TRUCK, LMTV, AND LMTV TRAILER 0013 00  
UNIT MAINTENANCE

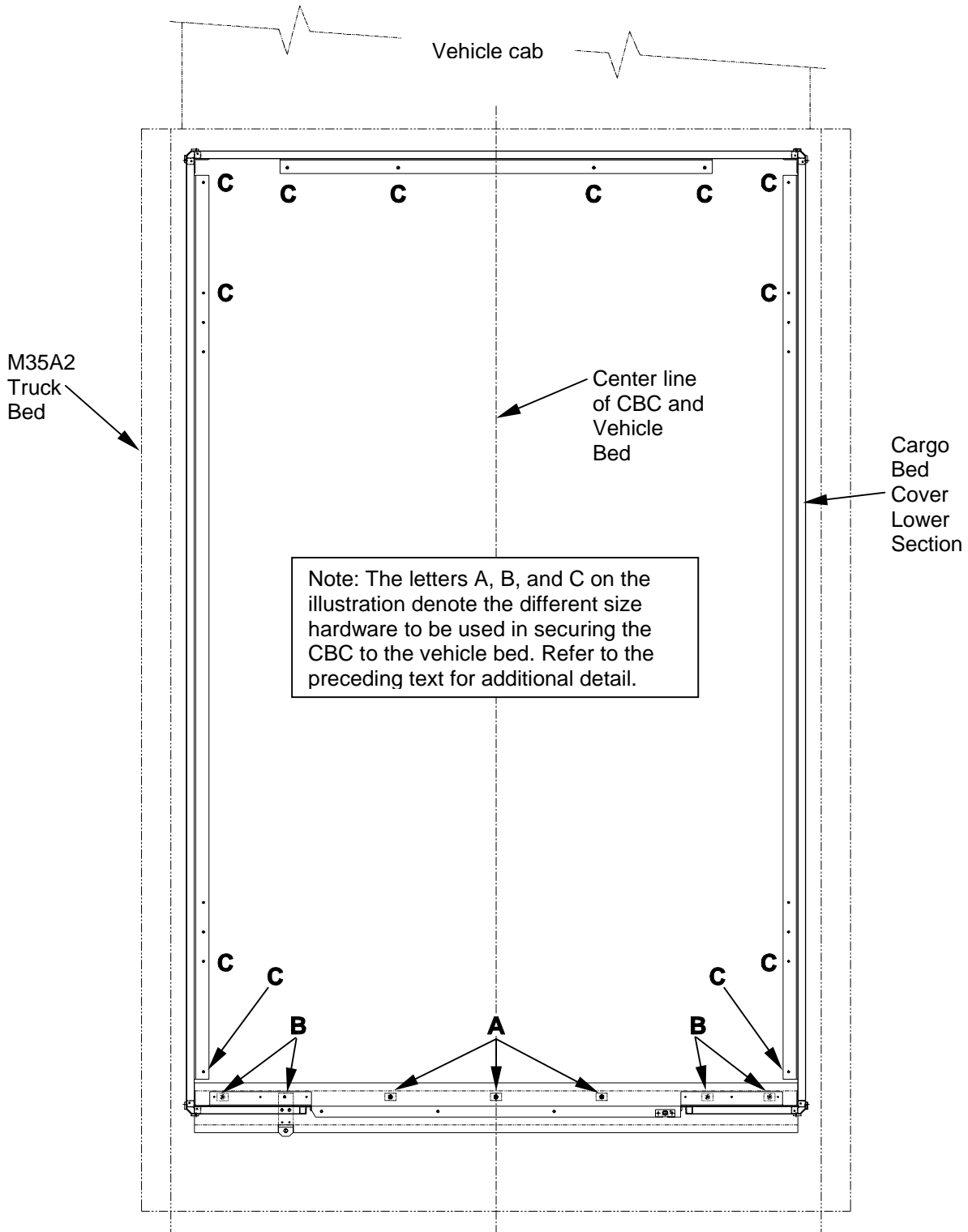

**CARGO BED COVER (CBC), TYPE III, 2 1/2 T CARGO TRUCK, LMTV, AND LMTV TRAILER 0013 00  
UNIT MAINTENANCE**

**APPLYING RTV SEALANT TO THRESHOLD AREA**

Once the CBC has been lowered into position and secured to the vehicle bed, RTV sealant must be applied around the threshold area (1) at the rear of the CBC.

To apply sealant around the threshold area, start at the left corner (2) of the CBC and inject sealant (3) under the area where the threshold (1) meets the vehicle bed (4). Fill the area sufficiently to create a good weather seal.

Continue to apply a bead of sealant all along the edge of the threshold (1) at the point where it meets the vehicle bed (4). Be sure to apply sealant around the hinge pivot pin area (5). Continue around the right corner (6) of the CBC and inject sealant under the right side of the threshold (7) as was done with the left corner.

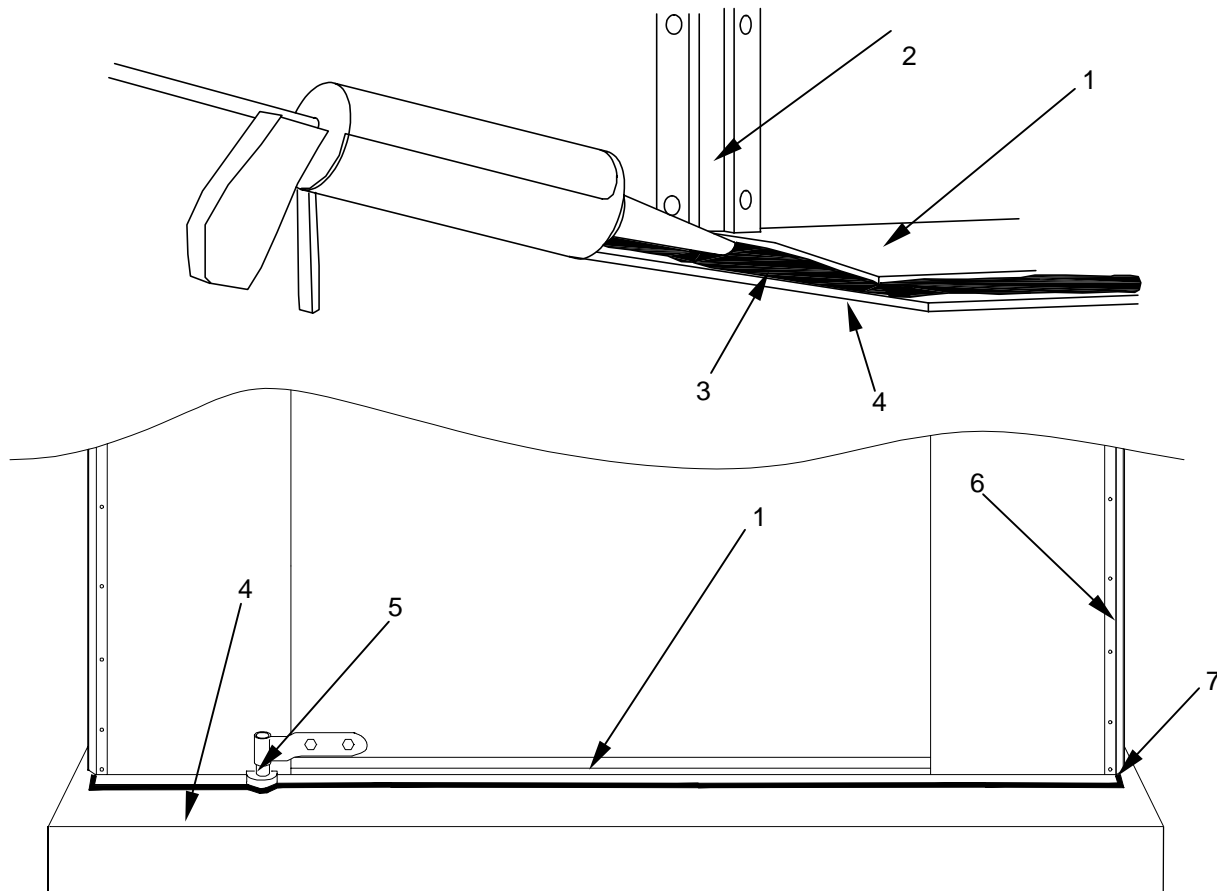

**Install Ladder.** Install the ladder onto the inside surface of the M35A2, 2 1/2 T Cargo Truck tailgate as detailed in WP 0016 entitled "Ladder Installation".

**END OF WORK PACKAGE**

---

**CARGO BED COVER (CBC), TYPE III, 2 1/2 T CARGO TRUCK, LMTV, AND LMTV TRAILER 0014 00  
UNIT MAINTENANCE**

---

**INSTALLATION OF MOUNTING KIT FOR M1078, 2 1/2 TON LMTV**

**THIS SECTION COVERS:**

Installation

---

**INITIAL SETUP**

Truck bed clean and free of debris

CBC prepared as detailed in WP 0010 and positioned near the vehicle on pallet

Mounting Kit unpacked and hardware organized on work surface

Side Panels and Tailgate removed (TM 9-2330-394-13&P)

**Maintenance Level**

**Materials/Parts**

Unit

**Tools and Special Tools**

General Mechanic Tool Kit (WP 0041, Table 2, Item 1)

Lifting Device (1 Ton minimum)

Caulking Gun, Ratchet Drive (WP 0041, Table 2, Item 7)

---

**General.** Before the Cargo Bed Cover can be installed on the bed of the M1078, 2 1/2 T LMTV, the bed surface should be cleaned of any foreign matter or other debris that would interfere with the installation process.

**INSTALLING WEATHER STRIPPING ON THE CBC**

Once the CBC has been separated from its shipping pallet and prepared for installation as outlined in the UNPACKING section of WP 0010, it must be extended to its operational position, if necessary, as outlined in WP 0005 entitled EXTENDING THE CARGO BED COVER TO AN OPERATIONAL POSITION.

Once the CBC **(1)** has been raised to an operational position, the CBC must be lifted and placed on supporting blocks **(2)** in order to gain access to the lower edge of the CBC for the installation of the weather stripping. A hoisting sling must be attached to lift the CBC in accordance with WP 0005. When initially positioning the blocks, it is best to place them first at the fore and aft ends to allow access to the left and right sides of the CBC and then to move them to the left and right sides to gain access to the fore and aft ends.

Once the CBC has been safely blocked, the weather stripping can be installed. Two thicknesses of weather stripping, individually labeled 3/16 inch and 1/8 inch, are included with the mounting plate installation kit. They are both supplied in rolls of 50 feet.

Apply the 3/16 inch weather stripping **(3)** to the bottom edge **(4)** of the Cargo Bed Cover **(1)** by removing the protective backing **(5)** from the weather stripping and pressing the adhesive side **(6)** into position. Do NOT apply the weather stripping to the bottom of the carrier mounting angles **(7)**. Be sure to allow the weather stripping to extend beyond the corners of the CBC by approximately 2 inches.

Add an second layer of 1/8 inch thick weather stripping **(8)** over the initial layer of 3/16 thick weather stripping **(3)**. Be sure to stagger the joints when applying the second layer so that a weather stripping joint on the first layer is not directly over a joint on the second layer. When complete, the total thickness of the weather stripping on the underside of the CBC should be 5/16 inch **(9)**.

In order to apply the weather stripping around the entire perimeter of the CBC, it will be necessary to lift the CBC and reposition the blocks **(2)**. Continue applying the 3/16 inch weather stripping **(3)** and 1/8 inch

**CARGO BED COVER (CBC), TYPE III, 2 1/2 T CARGO TRUCK, LMTV, AND LMTV TRAILER 0014 00  
UNIT MAINTENANCE**

weather stripping (8) around the entire bottom edge of the CBC (4) as well as to the underside of the threshold (10).

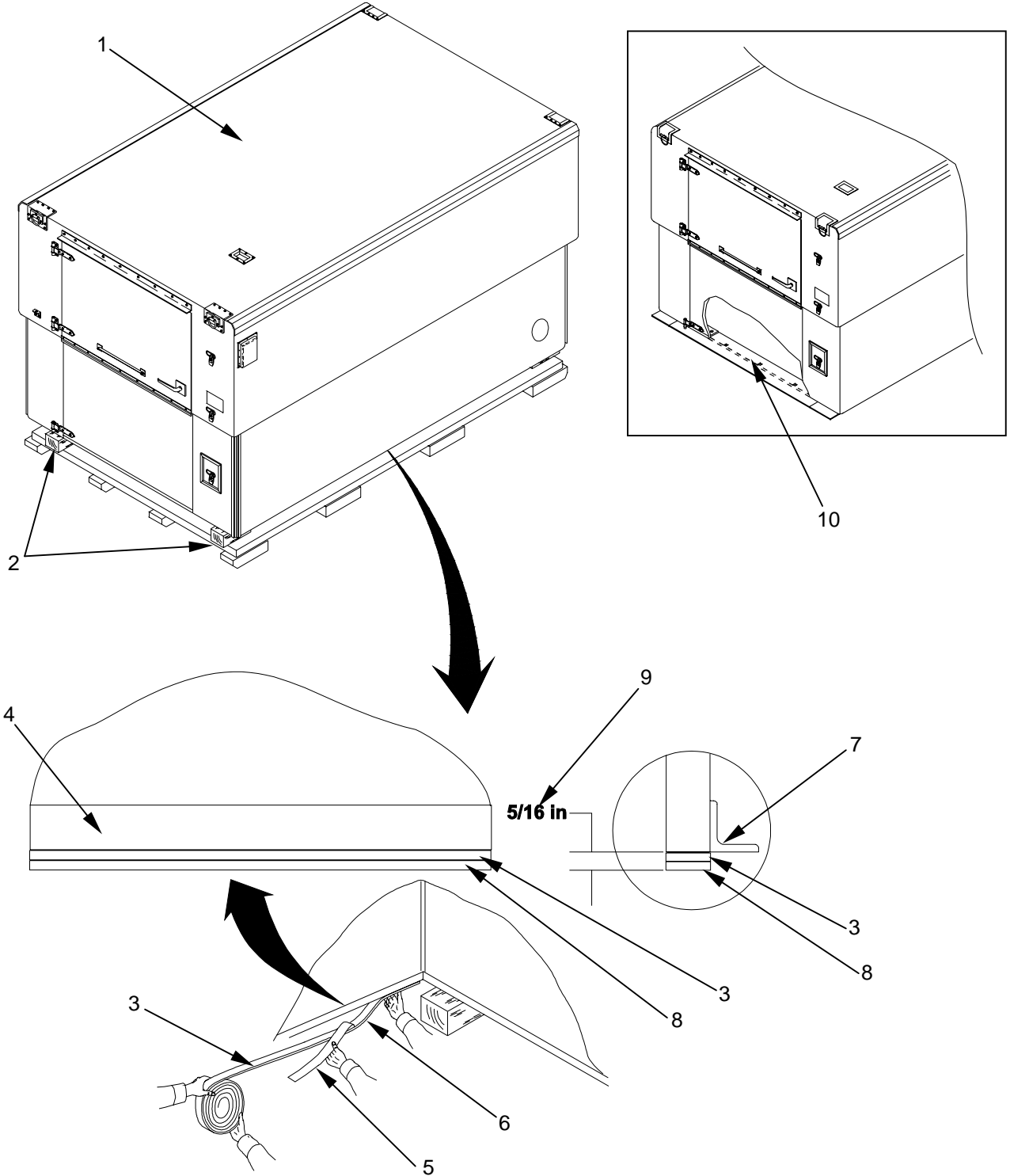

---

**CARGO BED COVER (CBC), TYPE III, 2 1/2 T CARGO TRUCK, LMTV, AND LMTV TRAILER 0014 00  
UNIT MAINTENANCE**

---

**INSTALLING WEATHER STRIPPING TO THE MOUNTING PLATE COMPONENTS**

There are four components to the mounting plate assembly, a front section **(1)**, rear section **(2)**, left side **(3)**, and right side **(4)**. Weather stripping must be installed on the side of each mounting plate component where the mounting plate contacts the vehicle bed. Weather stripping is also applied on the ends **(5)** of each side plate **(3,4)** where the plates will eventually butt against the front **(1)** and rear sections **(2)**.

To install the weather stripping to the mounting plate components, position each component on a work surface so that the marked side of the mounting plate faces up. Remember that this will be the side of the mounting plate that will contact the vehicle bed once it is installed on the CBC and secured to the vehicle.

Position the mounting plate components as shown so that the left (driver) side mounting plate **(3)** which is labeled "ROADSIDE" is positioned on the **RIGHT** side of the work area and the right (passenger) side mounting plate **(4)** which is labeled "CURBSIDE" is positioned on the **LEFT** side of the work area. Remember that the mounting plate components are laid out upside down on the work area.

Remove the protective backing **(6)** from the 3/16 inch thick weather stripping **(7)** included with the installation kit and apply the adhesive side of the weather stripping on the mounting plate component as illustrated. An outline on the mounting plate shows where the weather stripping is to be applied. Sections of weather stripping should be cut and applied at a right angle whenever the weather stripping changes direction.

Continue applying the 3/16 inch weather stripping **(7)** until it has been applied to all mounting plate components.

Apply a second layer of 1/8 inch weather stripping **(8)** on top of the 3/16 inch layer **(7)** already in place. Be sure to stagger the joints **(9)** so that joints on the 3/16 inch and 1/8 inch layers are not in the same location. Press all weather stripping firmly in place.

Apply a section of 3/16 inch wide weather stripping approximately 3-1/4 inches in length along each end **(5)** of each **side** mounting plate section. This weather stripping will seal the areas where the side sections butt up against the front and rear mounting plate sections when they are installed on the CBC.

**CARGO BED COVER (CBC), TYPE III, 2 1/2 T CARGO TRUCK, LMTV, AND LMTV TRAILER 0014 00 UNIT MAINTENANCE**

**NOTE:** This illustration depicts the **UNDERSIDE** of the mounting plate. This is the side that contacts the vehicle bed once the mounting plate is installed on the CBC.

Remember that the mounting plate is positioned **UPSIDE DOWN** on the work surface in order to apply weather stripping. The two side mounting plates are arranged on the work surface opposite their final installed positions on the CBC.

Side Plate labeled **"CURBSIDE"** should be placed here to apply weather stripping. Its **final** position will be on the passenger side of the CBC.

Side Plate labeled **"ROADSIDE"** should be placed here to apply weather stripping. Its **final** position will be on the driver side of the CBC.

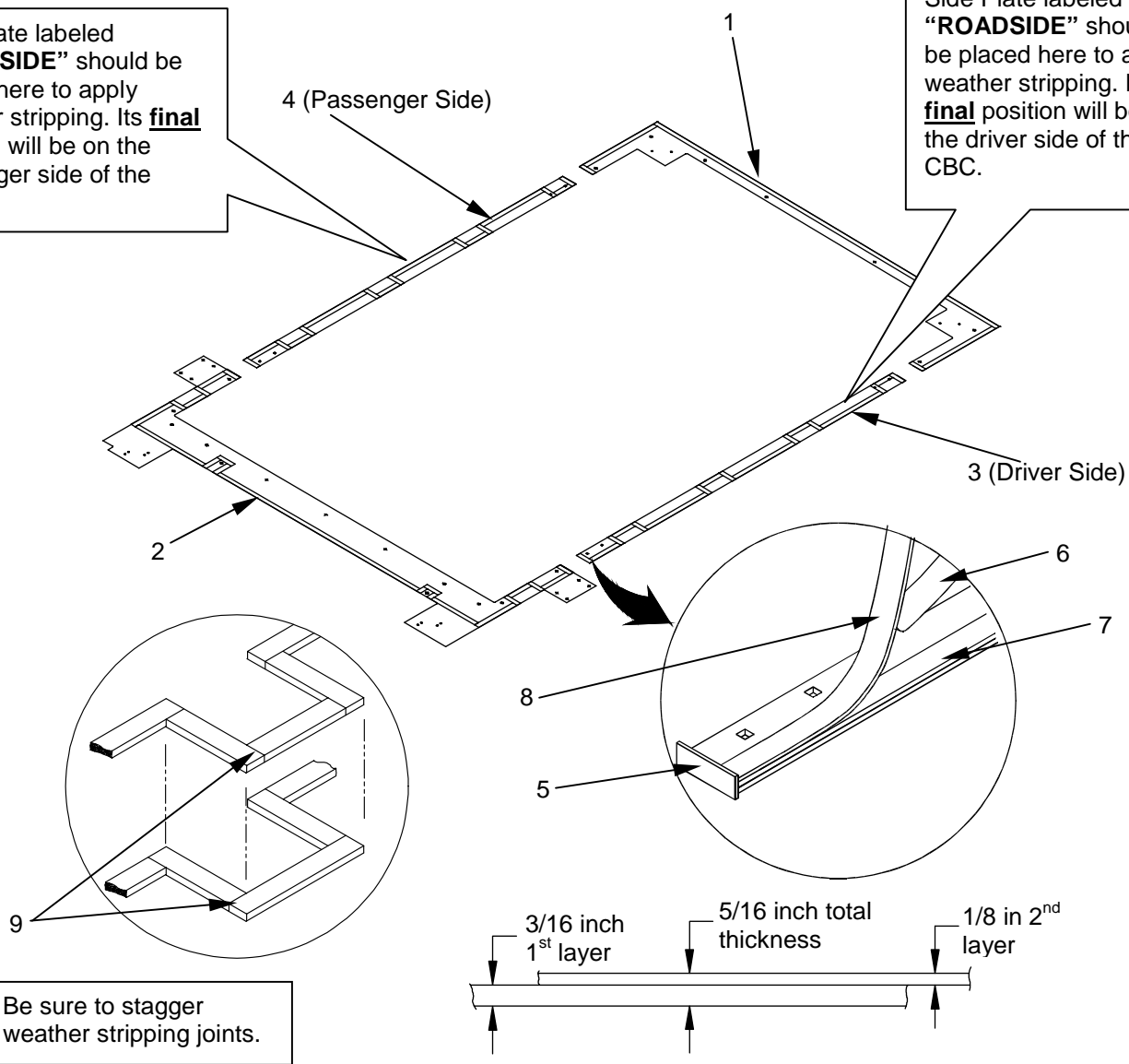

Be sure to stagger weather stripping joints.



**CARGO BED COVER (CBC), TYPE III, 2 1/2 T CARGO TRUCK, LMTV, AND LMTV TRAILER 0014 00  
UNIT MAINTENANCE**

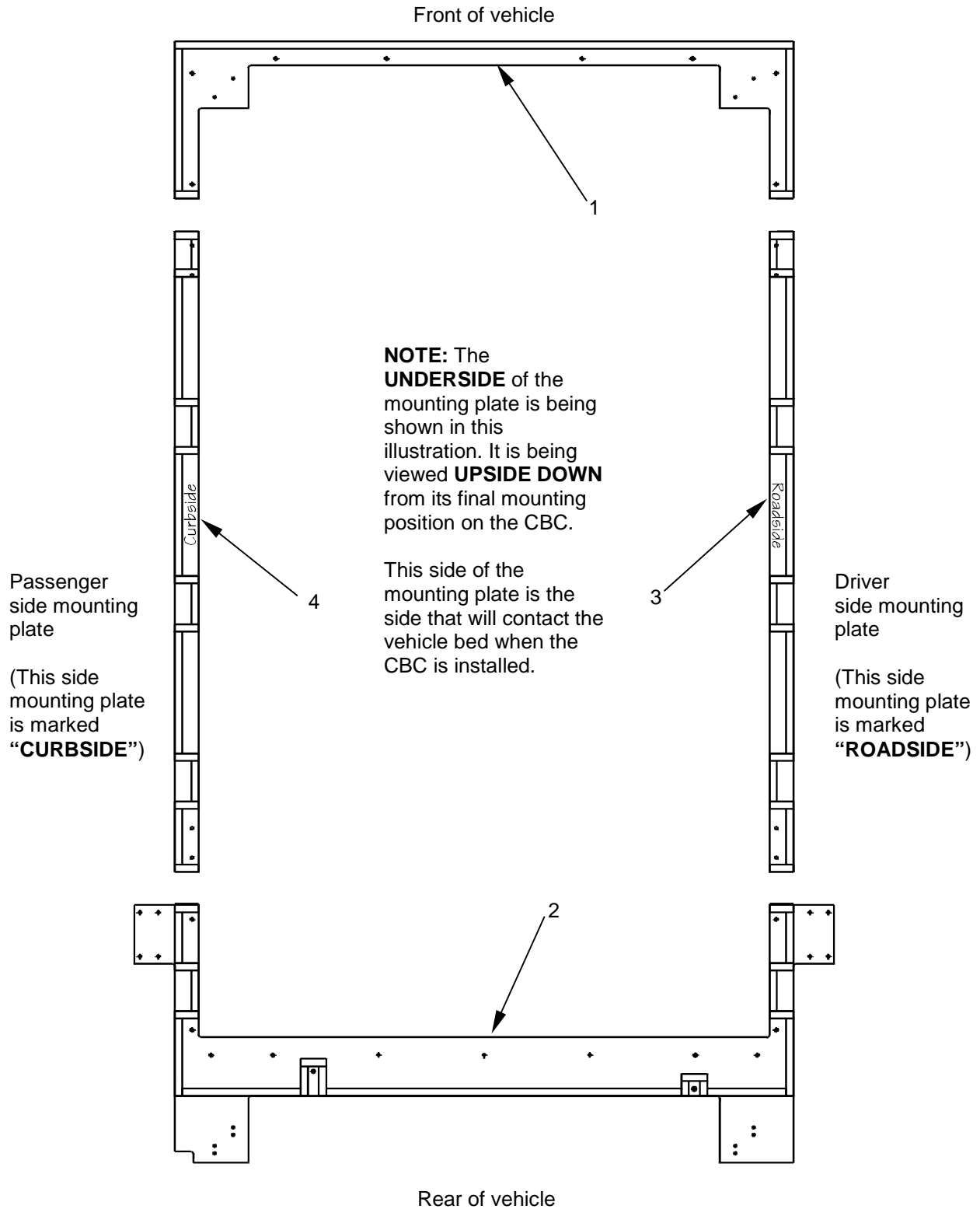

**INSTALLING THE MOUNTING PLATE TO THE CARGO BED COVER**

The mounting plate assembly mounts to the carrier mounting angles located at the bottom of the lower section of the CBC. The individual sections are secured to the carrier mounting angles using carriage bolts, pan head screws, flat washers, lock washers, and nuts supplied with the mounting plate installation kit.

**Installing the front mounting plate section.** Before installing the front and rear mounting plate sections, be sure that the supporting blocks are located under the side walls of the CBC and are approximately 24 inches from the corners. This will provide adequate room to install the front and rear sections.

To install the front mounting plate section (1) to the CBC (2), position the section under the front carrier mounting angle (3) of the CBC so that the face of the mounting plate section with the applied weather stripping faces DOWN and toward the vehicle bed.

Press the mounting plate (1) up into position and align the holes (4) on the mounting plate with the holes (5) on the carrier mounting angles (3).

Have a second person hold the mounting plate section (1) securely in position and install a total of eight 5/16-18 UNC x 1 inch long carriage bolts (6) up through the mounting plate (1) and through the CBC carrier mounting angle (3). Install one 5/16 inch flat washer (7) over the end of the bolt and against the surface of the carrier mounting angle, followed by a 5/16 inch lockwasher (8) and 5/16 UNC hex nut (9). Repeat for all remaining screws.

Hand tighten all hardware, but do not tighten securely at this time.

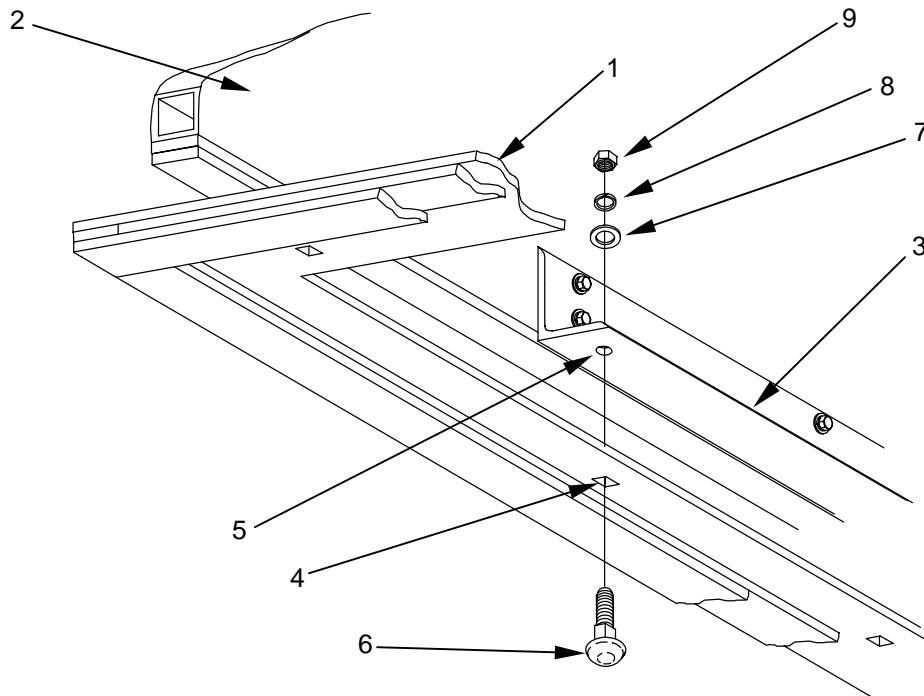

**CARGO BED COVER (CBC), TYPE III, 2 1/2 T CARGO TRUCK, LMTV, AND LMTV TRAILER 0014 00  
UNIT MAINTENANCE**

**Installing the rear mounting plate section.** To install the rear mounting plate section **(13)** to the CBC, position the section under the threshold **(14)** of the CBC so that the face of the mounting plate section with the applied weather stripping faces **DOWN** and toward the vehicle bed. The threshold is the area on either side of the personnel door opening.

Press the mounting plate up **(13)** into position and align the holes on the mounting plate with the holes in the threshold **(14)**. Align the holes at the ends of the rear mounting plate with the holes on the side wall carrier mounting angle sections nearest the corners of the CBC.

Have a second person hold the mounting plate section in position and install a total of four, 5/16-18 UNC x 1 1/4 inch long carriage bolts **(15)** up through the mounting plate and the holes in the CBC threshold on either side of the personnel door opening. Install one 5/16 inch flat washer **(16)** over the end of the bolt and against the surface of the threshold **(14)** followed by a 5/16 inch lockwasher **(17)** and 5/16 UNC hex nut **(18)**.

Install four, 5/16-18 UNC x 1 inch long carriage bolts **(8)** up through the ends of the rear mounting plate **(13)** and the holes in the CBC carrier mounting angles along the side walls nearest the corners. Install one 5/16 inch flat washer **(9)** over the end of the bolt and against the surface of the carrier mounting angle followed by a 5/16 inch lockwasher **(10)** and 5/16 UNC hex nut **(11)**.

Install three, 5/16-18 UNC x .63 inch long pan head screws **(19)** **DOWN** through the section of the CBC threshold at the door opening and into threaded inserts **(20)** mounted in the mounting plate with a 5/16 inch lockwasher **(21)** under each head.

Hand tighten all hardware. Do not tighten securely at this time.

**Installing the left side (driver or roadside) mounting plate section.** Before installing the side mounting plate sections **(1,12)**, lift the CBC with the hoisting sling and reposition the supporting blocks under the front and rear mounting plate sections that were installed earlier. This will allow access to the side walls of the CBC.



**NOTE**

The holes for the side mounting plate sections may be partially obscured by the weather stripping installed earlier. To install the carriage bolt properly, move the weather stripping aside slightly to gain access to the hole. Install the carriage bolt so that it seats properly against the mounting plate. Make sure that the square portion under the head of the bolt fits into the square hole of the mounting plate. Reposition the weather stripping over the head of the carriage bolt.

Install the left side mounting plate section **(1)** in the same fashion as for the front **(2)** and rear **(13)** sections detailed above. Be sure to butt the ends **(3)** of the side section with the additional sections of weather stripping against the end **(4)** of the front section **(2)** and rear section **(13)**.

Press the left side mounting plate section **(1)** up into position and align the holes **(5)** on the mounting plate with the holes **(6)** on the carrier mounting angles **(7)**.

---

**CARGO BED COVER (CBC), TYPE III, 2 1/2 T CARGO TRUCK, LMTV, AND LMTV TRAILER 0014 00  
UNIT MAINTENANCE**

---

Have a second person hold the left side mounting plate section **(1)** in position and install a total of four 5/16-18 UNC x 1 inch long carriage bolts **(8)** up through the mounting plate **(1)** and the CBC carrier mounting angle **(7)**.

Install one 5/16 inch flat washer **(9)** over the end of the bolt and against the surface of the carrier mounting angle **(7)** followed by a 5/16 inch lockwasher **(10)** and 5/16 UNC hex nut **(11)** for each of the remaining bolts.

Tighten all hardware by hand but do not tighten securely at this time.

**Installing the right side (passenger or curbside) mounting plate section.** Install the right side mounting plate section **(12)** in the same fashion as for the left mounting plate section detailed previously. Be sure to butt the ends of the side section with the additional weather stripping against the end of the front and rear section.

Press the right side mounting plate section up into position and align the holes on the mounting plate with the holes on the carrier mounting angles.

Have a second person hold the right side mounting plate section in position and install a total of four 5/16-18 UNC x 1 inch long carriage bolts up through the mounting plate and the CBC carrier mounting angle.

Install one 5/16 inch flat washer over the end of the bolt and against the surface of the carrier mounting angle followed by a 5/16 inch lockwasher and 5/16 inch UNC hex nut for each of the remaining bolts.

Once all four sections of the mounting plate assembly have been installed, tighten all hardware securely.

CARGO BED COVER (CBC), TYPE III, 2 1/2 T CARGO TRUCK, LMTV, AND LMTV TRAILER 0014 00  
UNIT MAINTENANCE

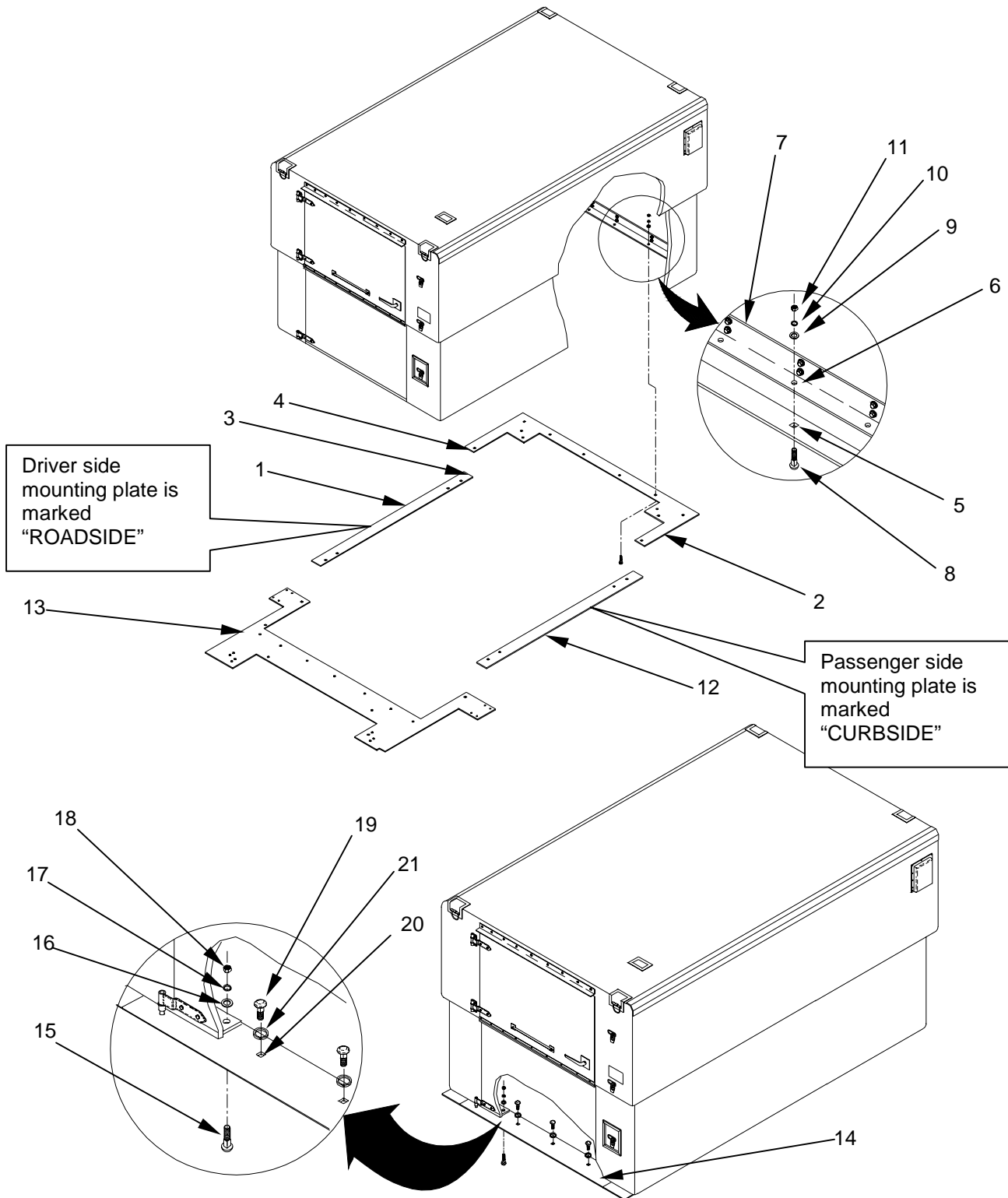

---

**CARGO BED COVER (CBC), TYPE III, 2 1/2 T CARGO TRUCK, LMTV, AND LMTV TRAILER 0014 00  
UNIT MAINTENANCE**

---

**INSTALLING TIEDOWN POST ASSEMBLIES**



**NOTE**

In order to mount the tiedown post assemblies to the mounting plate assembly, the supporting blocks used to raise the CBC/mounting plate combination must be selected to raise the CBC at least 8-1/2 inches in order to allow adequate clearance for the installation of the tiedown post assemblies.

Four tiedown post assemblies **(1)** are installed at the four corners of the mounting plate assembly **(2)**. These tiedown post assemblies will later be lowered into holes **(3)** on the vehicle bed **(4)** and help to secure the CBC and Mounting Plate combination to the vehicle bed.

To install the rear tiedown post assemblies, locate the tiedown post mounting holes **(5)** located at the corners of the rear mounting plate sections. Be sure to use the forward set of mounting holes when installing the rear tiedown post assemblies.

Position one tiedown post spacer plate **(6)** under one corner of the mounting plate and align the mounting holes **(7)** in the spacer plate with the forward mounting holes **(5)** in the mounting plate.

Position one tiedown post assembly **(1)** in position under and against the spacer plate **(6)** positioned above. Align all mounting holes.

Install two 5/16 inch (.328 inch ID x 1.375 inch OD x .063 inch thick) flat washers **(8)**, followed by 5/16 inch lockwasher **(9)** and 5/16 inch UNC x 1 3/4 inch long hex head screw **(10)** down through the mounting plate **(2)**, spacer plate **(6)**, and into the tiedown post assembly **(1)**. Repeat for the second mounting hole.

Hand tighten the screws into the rivnuts **(11)** installed in the tiedown post assembly **(1)**.

Do not tighten the screws securely at this time. The screw installation holes are oversized slightly to allow the tiedown posts to move slightly.

Install the other rear tiedown post assembly.

Install the two front tiedown post assemblies in the corners of the front mounting plate assembly in similar fashion.

CARGO BED COVER (CBC), TYPE III, 2 1/2 T CARGO TRUCK, LMTV, AND LMTV TRAILER 0014 00  
UNIT MAINTENANCE

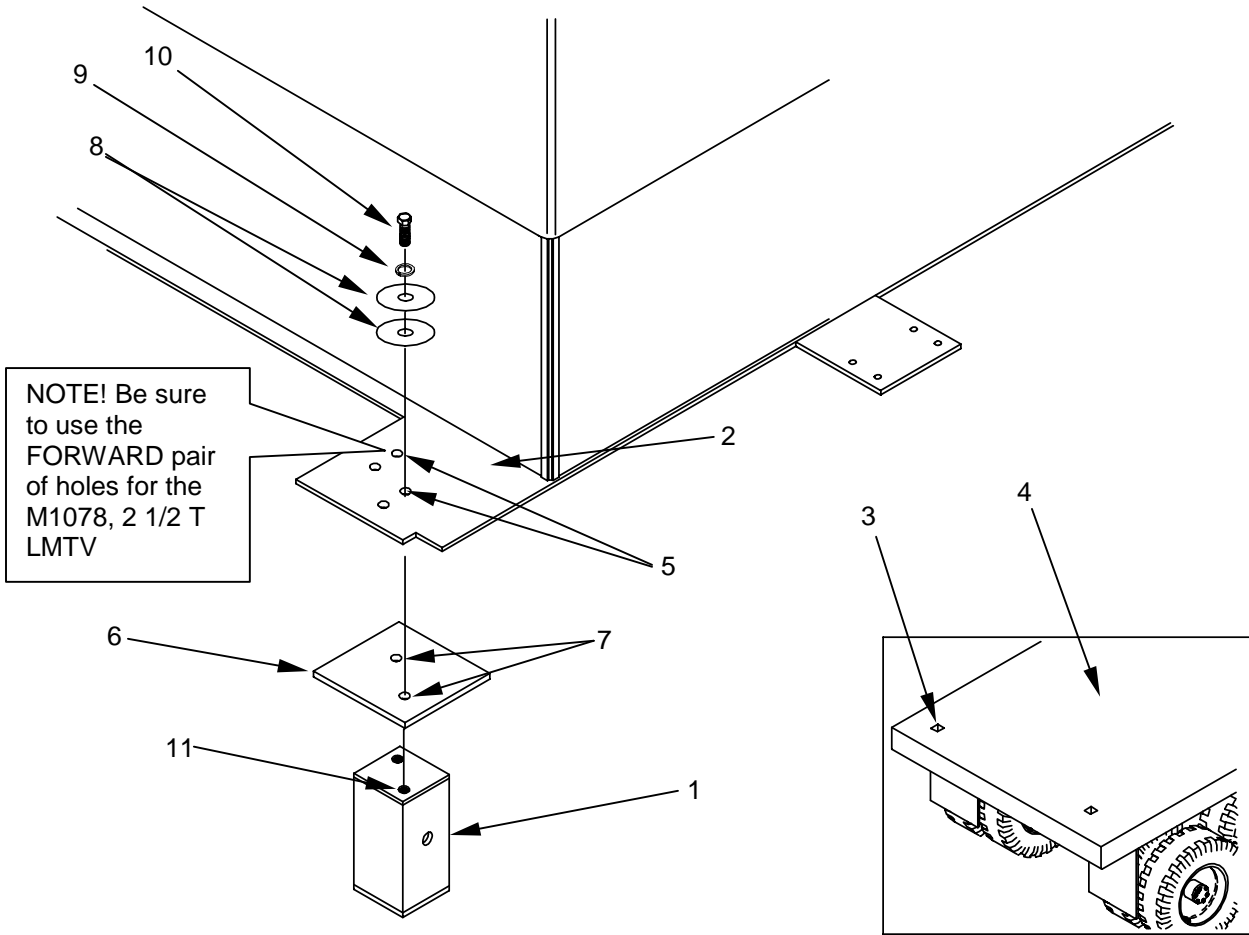

**CARGO BED COVER (CBC), TYPE III, 2 1/2 T CARGO TRUCK, LMTV, AND LMTV TRAILER 0014 00  
UNIT MAINTENANCE**

**INITIAL INSTALLATION OF CLAMP PLATE CHANNEL**

Before the CBC and mounting plate combination are mounted on the vehicle bed, the clamp plate channel must be installed. A clamp plate channel is installed on either side of the mounting plate and helps to secure the CBC/mounting plate combination to the vehicle bed.

To install the initial portion of the clamp plate assembly, position one clamp plate assembly spacer plate (1) on the underside of the extension (2) that extends from the side of the rear mounting plate section (3). Be sure to position the spacer plate with the countersunk hole side facing down. Align the holes (4) in the spacer plate (1) with the holes (5) in the mounting plate extension (2).

Position the clamp plate channel (6) on the top surface of the mounting plate extension (2), aligning the four holes (7) in the clamp plate channel (6) with the four holes (5) in the mounting plate extension (2).

While holding the spacer plate (1) and clamp plate channel (6) in position on the mounting plate extension (2), install a 5/16-18 UNC x 1.28 inch long flat head screw (8) up through the spacer plate (1), mounting plate extension (2), and exiting the top of the clamp plate channel (6).

Secure the screw (8) with one 5/16 inch flat washer (9), and 5/16 inch UNC hex locknut (10). Install the remaining three flat head screws and associated hardware. Tighten all hardware securely.

Repeat for the opposite side of the CBC mounting plate.

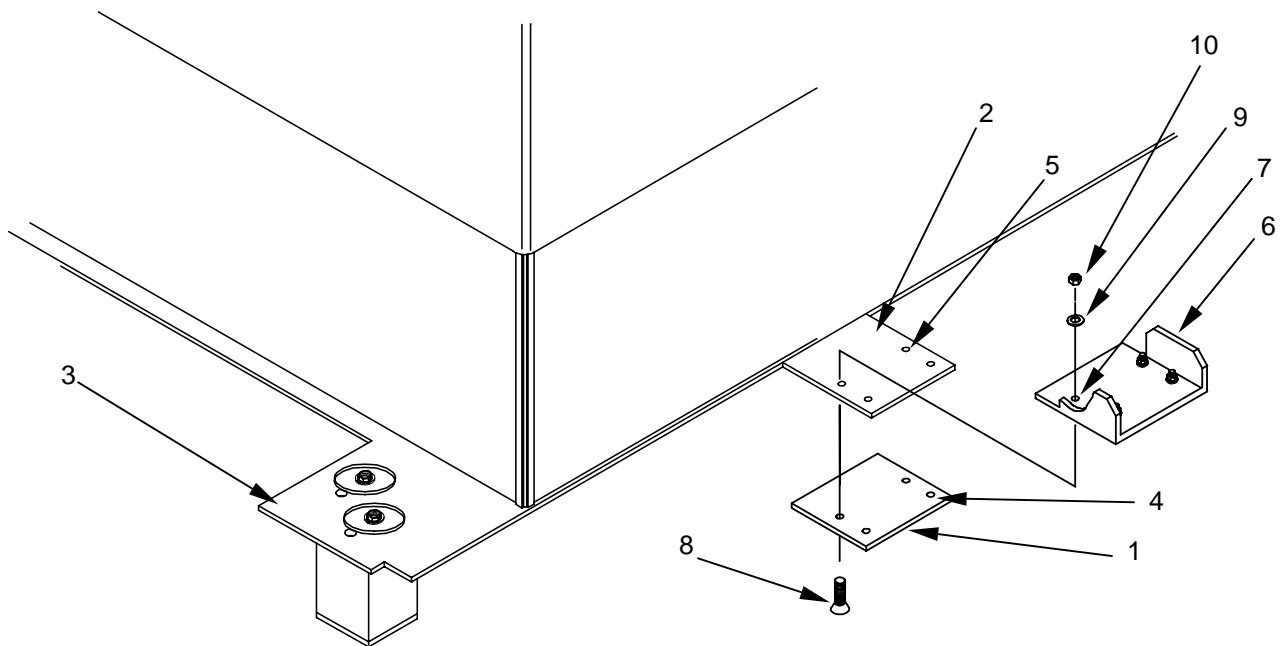



**CARGO BED COVER (CBC), TYPE III, 2 1/2 T CARGO TRUCK, LMTV, AND LMTV TRAILER 0014 00  
UNIT MAINTENANCE**

**Removing the plugs in the LMTV bed.** Before the CBC and mounting plate combination can be lowered into the pockets located on the vehicle bed, the protective plugs in the bed must be removed.

To remove the plugs **(1)** in the vehicle bed **(2)**, reach under the bed and pull the retaining pin **(3)** that secures the plug in place.

Push the plug **(1)** down and through the vehicle bed pocket **(4)**.

Push the plugs in the remaining three holes through the vehicle bed **(2)**.

The plugs are attached to the vehicle bed with a wire rope tether **(5)**. The plugs will be secured to the base of the tiedown post assembly in a later step.

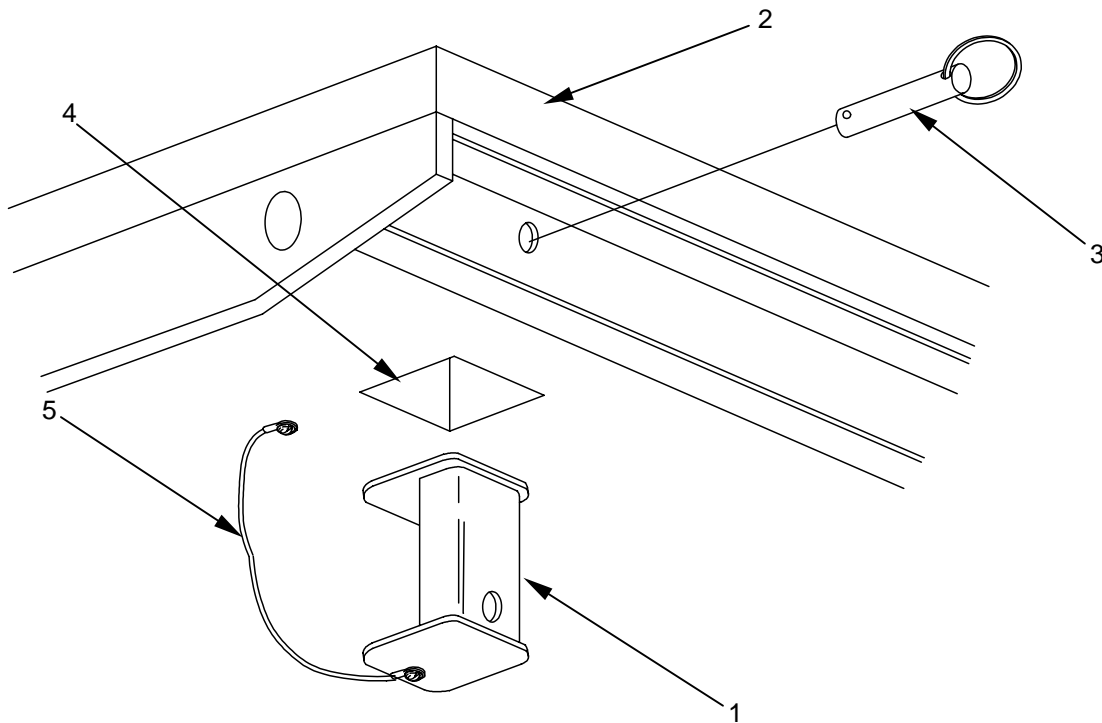

---

**CARGO BED COVER (CBC), TYPE III, 2 1/2 T CARGO TRUCK, LMTV, AND LMTV TRAILER 0014 00  
UNIT MAINTENANCE**

---

**LOWERING THE CBC ONTO THE VEHICLE BED**

Once the mounting plate assembly **(1)** has been completely installed on the bottom of the Cargo Bed Cover **(2)**, the CBC can be carefully lowered onto the vehicle bed **(3)**.



**NOTE**

It is important to ensure that the CBC and mounting plate combination is level when lowered into position on the vehicle bed or the tie down post assemblies may bind as they are lowered into the vehicle bed pockets. Since the weight of the CBC is not distributed evenly, the CBC may tilt toward the rear when lifted with the hoisting sling. To compensate for this condition and to ensure that the CBC is level, additional weight such as two 50 pound sandbags or other weight should be placed toward the front edge of the roof.

To secure the CBC and mounting plate combination to the vehicle bed of the LMTV, lift the CBC (currently supported by blocks), using the hoisting sling **(4)** and slowly lower it into position on the bed **(3)** of the LMTV. Be sure that the CBC is level as it is suspended in the air.

Align the four tiedown post assemblies **(5)** into the four corresponding pockets **(6)** in the vehicle bed **(3)**.

Once all four tiedown posts **(5)** are engaged in the pockets **(6)** in the vehicle bed **(3)**, lower the CBC all the way to the surface of the vehicle bed.

Do not secure the tiedown post assemblies at this time.

CARGO BED COVER (CBC), TYPE III, 2 1/2 T CARGO TRUCK, LMTV, AND LMTV TRAILER 0014 00  
UNIT MAINTENANCE

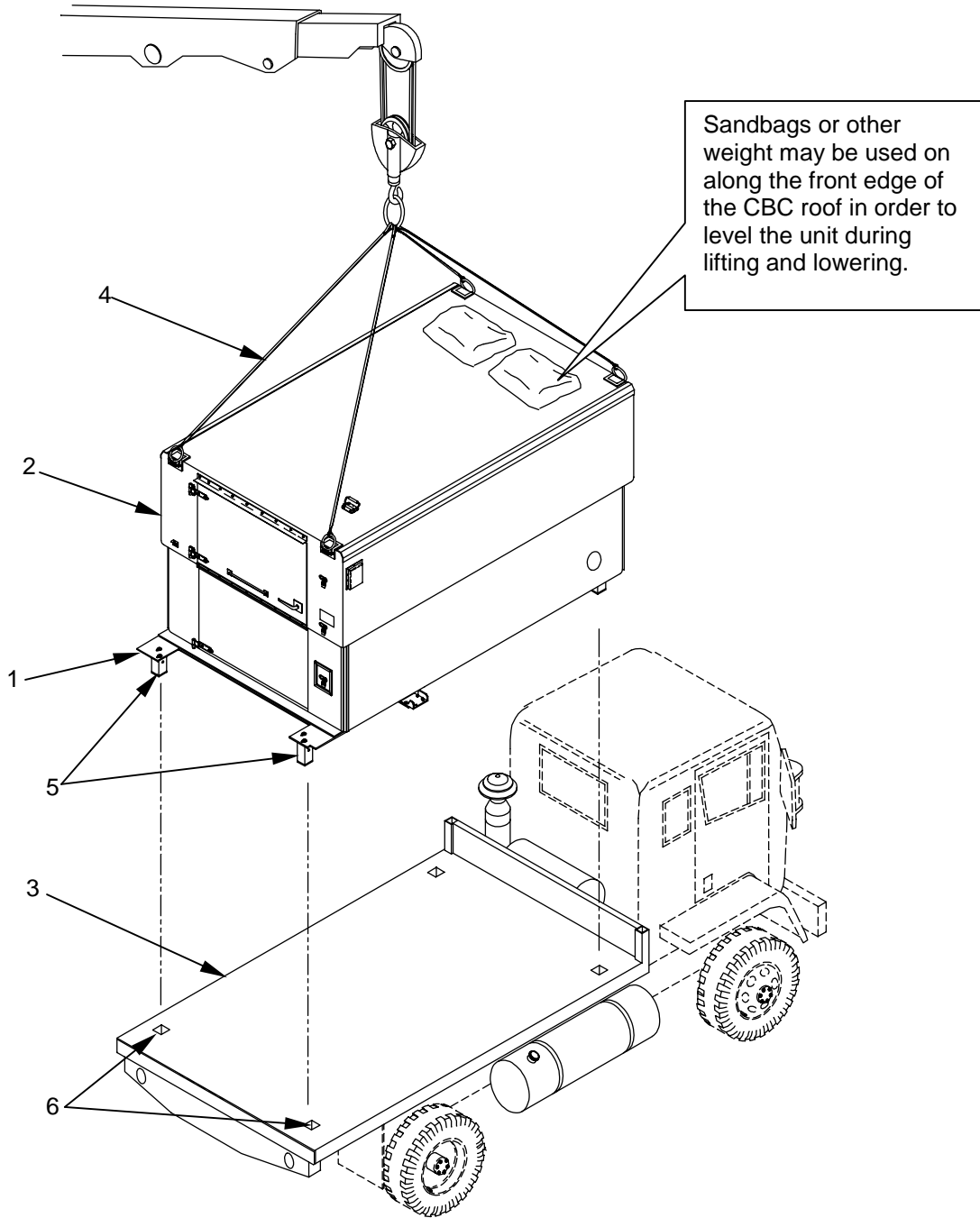

---

**CARGO BED COVER (CBC), TYPE III, 2 1/2 T CARGO TRUCK, LMTV, AND LMTV TRAILER 0014 00  
UNIT MAINTENANCE**

---

**IDENTIFYING GAPS BETWEEN THE CBC AND THE VEHICLE BED**

Once the CBC is in its final mounting position on the vehicle bed, the weather stripping seal must be inspected in order to detect any gaps that may exist between the weather stripping on the underside of the mounting plate **(1)** and the vehicle bed **(2)**. These gaps are typically caused by dents and other irregularities in the surface of the vehicle bed.

To inspect the quality of the weather stripping seal, use a flashlight and walk around the outside of the CBC at vehicle bed level. Shine the light where the weather stripping and vehicle bed meet.

Using chalk, masking tape, or other temporary marking instrument, mark those areas of the CBC where gaps can be seen. To inspect the quality of the weather stripping seal at the front of the CBC, it will be necessary to enter the CBC and conduct the inspection from the inside.

Estimate the width of each gap area in order to determine whether 3/16 inch or 1/8 inch weather stripping is required to properly fill the gap. Make a note of the thickness required with chalk or on a piece of masking tape placed in the area of the gap. Note that in some cases it may be necessary to use some combination of both sizes of weather stripping in order to properly close the gap.

Once the gaps have been identified and marked, raise the CBC using the hoisting sling to a comfortable working height and apply additional weather stripping in the marked areas.

When the additional weather stripping has been installed, lower the CBC back into position on the vehicle bed. Inspect the quality of the seal using the method described above. If any gaps are still seen, mark the areas and apply additional layers of weather stripping as required.

Continue this process until no gaps are present.

CARGO BED COVER (CBC), TYPE III, 2 1/2 T CARGO TRUCK, LMTV, AND LMTV TRAILER 0014 00  
UNIT MAINTENANCE

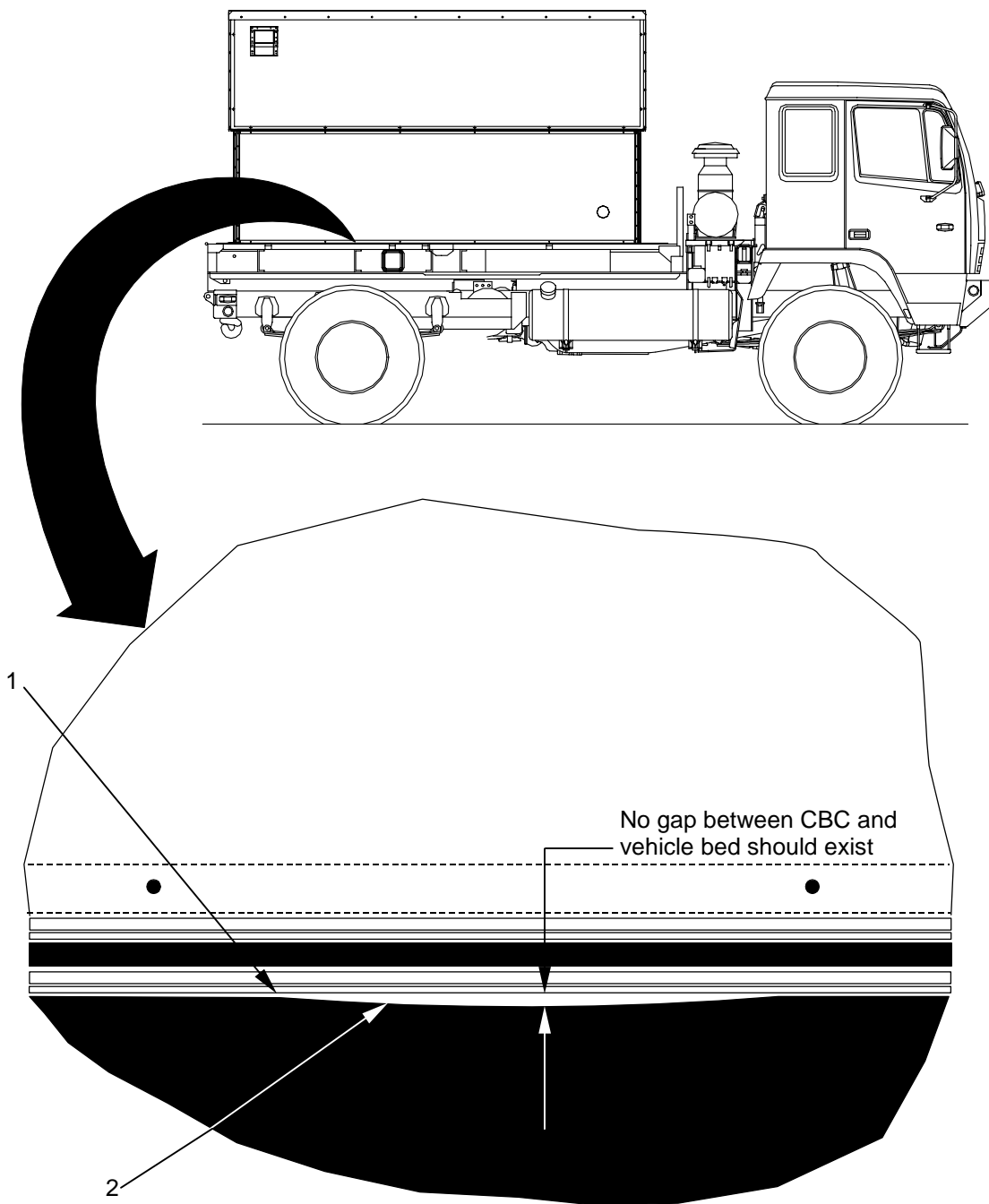

APPLYING RTV SILICONE SEALANT



**NOTE**

Sealant should be applied only if the CBC is to be immediately mounted to the vehicle bed. The sealant has a working time of approximately 20 minutes and will start to cure after that time. Installing the CBC on the vehicle after the sealant begins to cure may adversely affect the sealant's ability to properly bond with the vehicle bed.

Once all gaps have been identified and eliminated as described previously, a bead of RTV (silicone) sealant must be applied where the weather stripping contacts the vehicle bed and around the threshold area.

To apply the RTV sealant, raise the CBC to a comfortable working height using the hoisting sling.

Install the supplied cartridge of sealant into a standard caulking gun. Trim the tip of the cartridge so that a bead approximately 3/16 to 1/4 inch in width can be applied.

Apply a continuous bead of sealant **(1)** 3/16 to 1/4 inch in width on the surface of the weather stripping **(2)** along the outer edge. Start at one point at the underside of the CBC and move around the entire perimeter of the CBC applying sealant to all weather stripping surfaces.

Once sealant has properly applied to all weather stripping surfaces, the CBC should be lowered into position on the vehicle bed.

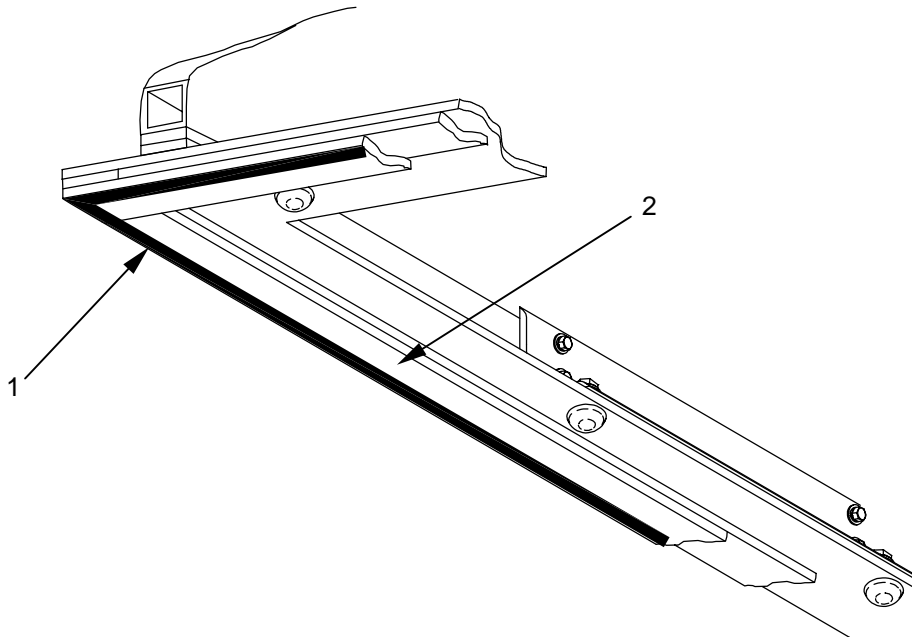

**CARGO BED COVER (CBC), TYPE III, 2 1/2 T CARGO TRUCK, LMTV, AND LMTV TRAILER 0014 00  
UNIT MAINTENANCE**

Once the CBC has been lowered into position on the vehicle bed, RTV sealant must be applied around the threshold area (1) at the rear of the CBC.

To apply sealant around the threshold area, start at the left corner (2) of the CBC and inject sealant (3) under the area where the threshold (1) meets the mounting plate (4). Fill the area sufficiently to create a good weather seal.

Continue to apply a bead of sealant all along the edge of the threshold (1) at the point where it meets the mounting plate (4). Be sure to apply sealant around the hinge pivot pin area (5). Continue around the right corner (6) of the CBC and inject sealant under the right side of the threshold (7) as was done with the left corner.

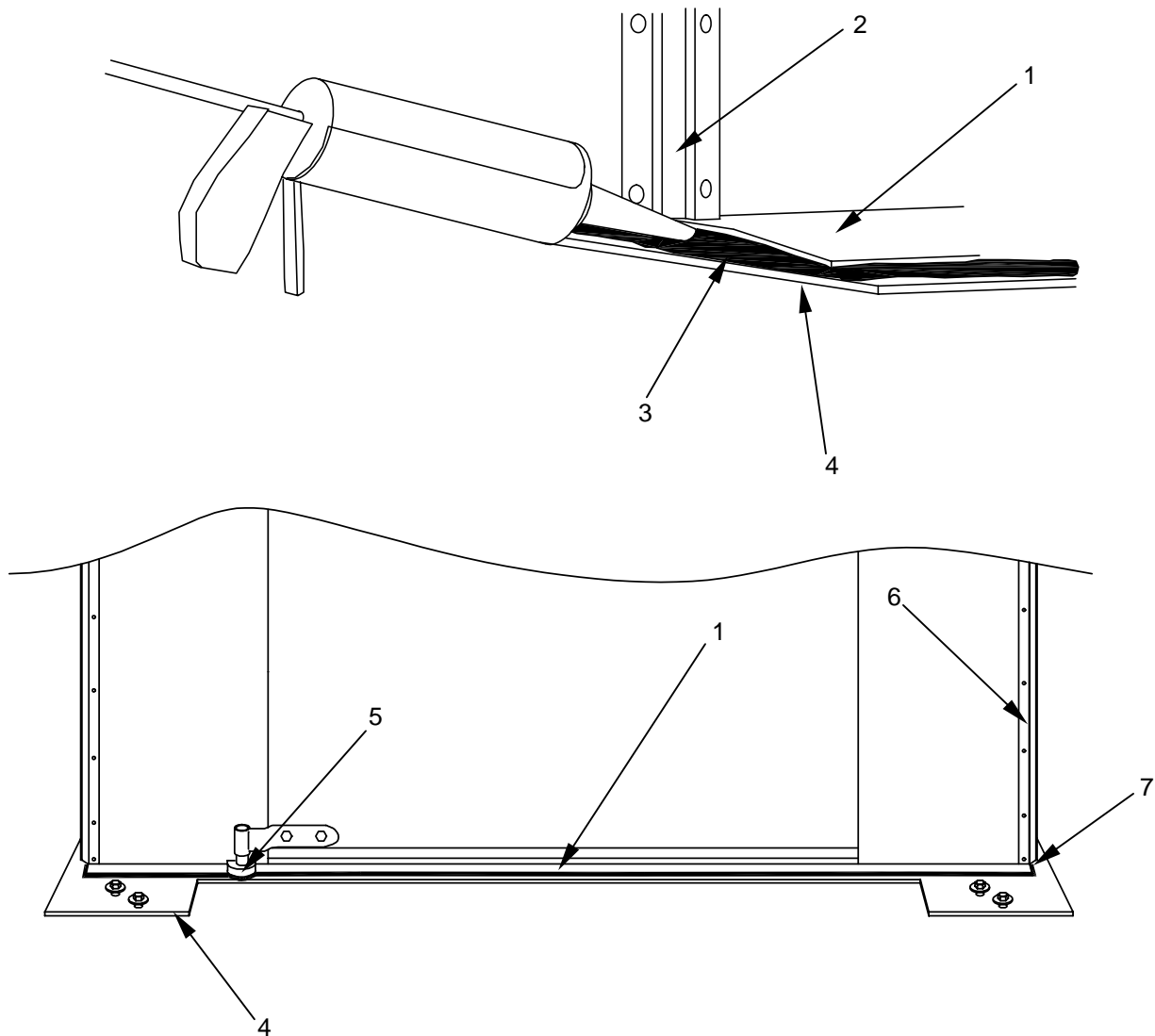

**SECURING THE TIEDOWN POST ASSEMBLIES**

To secure the tiedown post assemblies, tighten the two bolts (1) located at the top of each tie down post assembly (2).

When the two top bolts of each tie down post assembly are secure, install one bottom plate (3) to the bottom of each tie down post assembly (2) from the underside of the vehicle bed (4). Place the vehicle bed plug (5) over the bottom plate (3) and align the hole in the plug with the hole in the bottom plate (this is done simply to secure the plug). Secure the plug (5) and bottom plate (3) to the base of the tie down post (2) using one flatwasher (6), lockwasher (7), and 3/8-16 UNC x 2 inch long bolt (8). Tighten securely.

Repeat for the remaining tie down post assemblies.

Install the pin (9) that previously secured the vehicle bed plugs into the side of the tie down post assemblies.

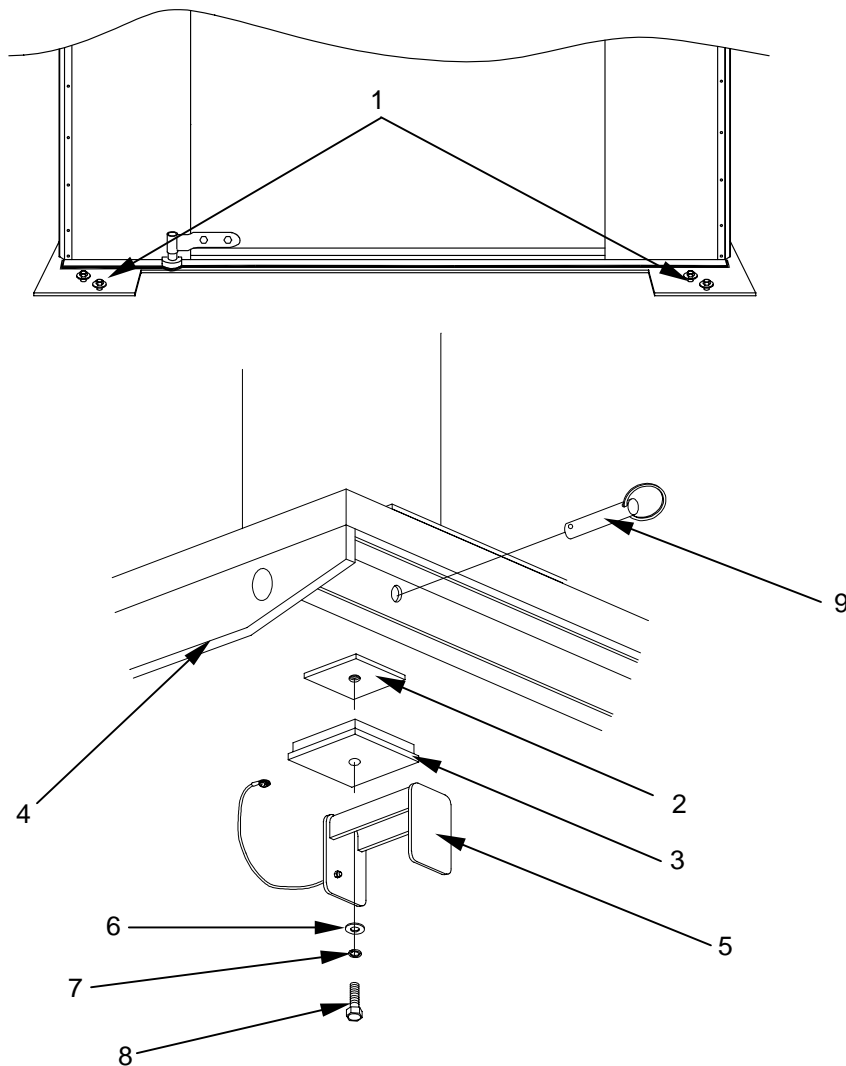



**CARGO BED COVER (CBC), TYPE III, 2 1/2 T CARGO TRUCK, LMTV, AND LMTV TRAILER 0014 00 UNIT MAINTENANCE**

**FINAL INSTALLATION OF CLAMP PLATE ASSEMBLIES**

Clamp plate assemblies (5) are installed on either side of the mounting plate assembly (2) and work in conjunction with the tie down post assemblies to secure the CBC/mounting plate combination to the vehicle bed.

When the CBC is in its final position, install two 1/2-13 UNC x 4.5 inch hex head bolts (3) through the holes in the clamp plate channel (1).

Install a spacer block (4) and clamp plate assembly (5) onto the bolts (3) and secure with 1/2 inch flat washer (6) and 1/2-13 UNC hex locknut (7). Be sure that the side of the clamp plate assembly (5) with the rubber pad (8) engages securely on the underside of the truck bed (9).

Repeat for the second clamp plate assembly located on the opposite side of the CBC.

Tighten all clamp plate assembly hardware securely.

Once the CBC has been properly secured to the vehicle, the Cargo Bed Cover is ready to be used as detailed in WP 0005 entitled "OPERATION UNDER USUAL CONDITIONS".

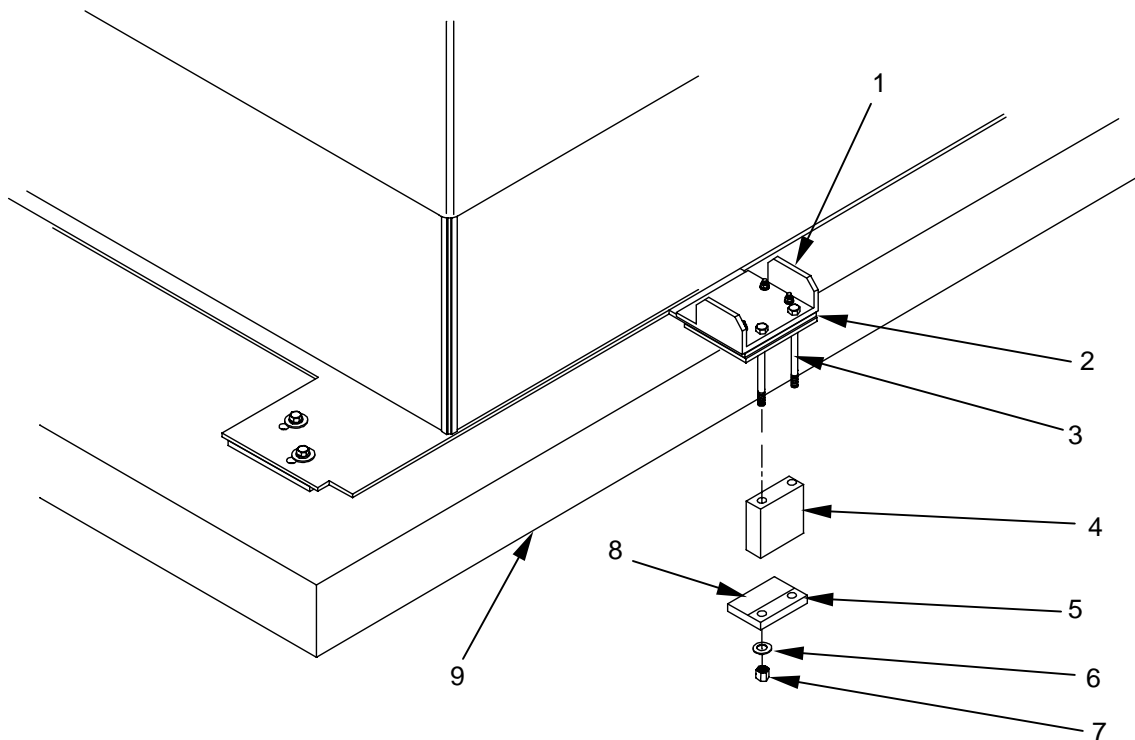

**END OF WORK PACKAGE**



**CARGO BED COVER (CBC), TYPE III, 2 1/2 T CARGO TRUCK, LMTV, AND LMTV TRAILER 0015 00 UNIT MAINTENANCE**

**INSTALLATION OF MOUNTING KIT FOR M1082, 2 1/2 TON LMTV TRAILER**

**THIS SECTION COVERS:**

Installation

**INITIAL SETUP**

- Trailer bed clean and free of debris
- CBC in fully extended position (WP 0005)
- CBC unpacked as detailed in (WP 0010) and positioned near the vehicle
- Mounting Kit unpacked and hardware organized
- Side panels and tailgate removed. (TM 9-2330-394-13&P)

**Maintenance Level**

Unit

**Materials/Parts**

**Tools and Special Tools**

- Lifting device (1 ton minimum)
- General Mechanic Tool Kit (WP 0041, Table 2, Item 1)
- Caeking Gun, Ratchet Drive (WP 0041, Table 2, Item 7)

**Personnel Required**

Two

**General.** Before the Cargo Bed Cover can be installed on the bed of the M1082, 2 1/2 T LMTV Trailer, the bed surface should be cleaned of any foreign matter or other debris that would interfere with the installation process.

**INSTALLING WEATHER STRIPPING ON THE CBC**

After verifying that the CBC **(1)** has been raised to an operational position, the CBC must be lifted and placed on supporting blocks **(2)** in order to gain access to the lower edge of the CBC for the installation of the weather stripping. A hoisting sling must be attached to lift the CBC in accordance with WP 0005. When initially positioning the blocks, it is best to place them first at the fore and aft ends to allow access to the left and right sides of the CBC and then to move them to the left and right sides to gain access to the fore and aft ends.

Once the CBC has been safely blocked, the weather stripping can be installed. Two thicknesses of weather stripping are included with the mounting plate installation kit, 3/16 inch and 1/8 inch. They are both supplied in rolls of 50 feet.

Apply the 3/16 inch weather stripping **(3)** to the bottom edge **(4)** of the Cargo Bed Cover **(1)** by removing the protective backing **(5)** from the weather stripping and pressing the adhesive side **(6)** into position. Do NOT apply the weather stripping to the bottom of the carrier mounting angles **(7)**. Be sure to allow the weather stripping to extend beyond the corners of the CBC by approximately 2 inches.

Add a layer of 1/8 inch thick weather stripping **(8)** over the initial layer of 3/16 thick weather stripping **(3)**. Be sure to stagger the joints when applying the second layer so that a weather stripping joint on the first layer is not directly over a joint on the second layer. When complete, the total thickness of the weather stripping on the underside of the CBC should be 5/16 inch **(9)**.

In order to apply the weather stripping around the entire perimeter of the CBC, it will be necessary to lift the CBC and reposition the blocks **(2)**. Continue applying the 3/16 inch weather stripping **(3)** and 1/8 inch weather stripping **(8)** around the entire bottom edge of the CBC **(4)** as well as the underside of the threshold **(10)**.

**CARGO BED COVER (CBC), TYPE III, 2 1/2 T CARGO TRUCK, LMTV, AND LMTV TRAILER 0015 00  
UNIT MAINTENANCE**

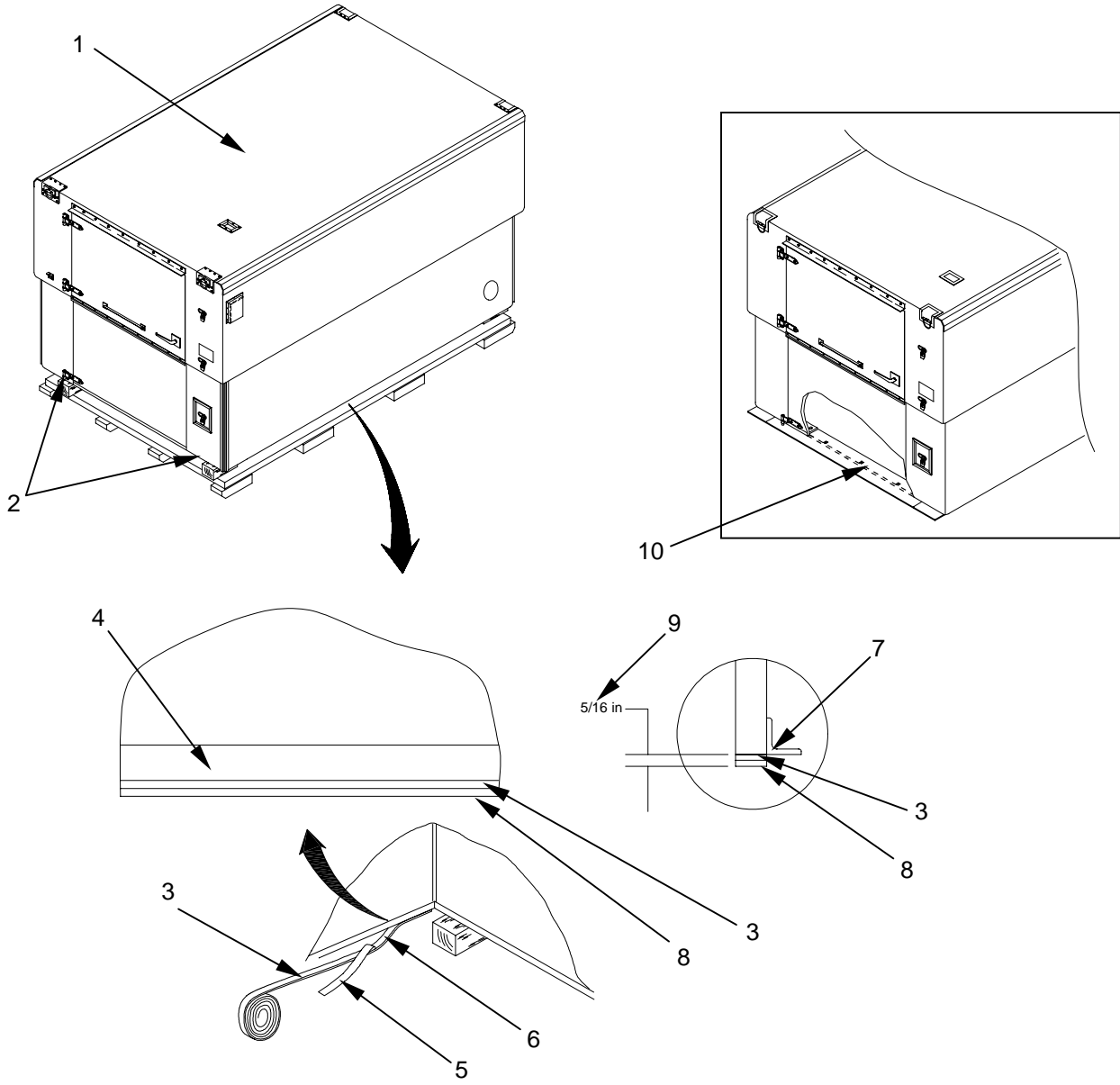

**INSIDE VIEW**

---

**CARGO BED COVER (CBC), TYPE III, 2 1/2 T CARGO TRUCK, LMTV, AND LMTV TRAILER 0015 00  
UNIT MAINTENANCE**

---

**INSTALLING WEATHER STRIPPING TO THE MOUNTING PLATE COMPONENTS**

There are four components to the mounting plate assembly, a front section **(1)**, rear section **(2)**, left side **(3)**, and right side **(4)**. Weather stripping must be installed on the side of each mounting plate component where the mounting plate contacts the vehicle bed. Weather stripping is also applied on the ends **(5)** of each side plate **(3,4)** where the plates will eventually butt against the front **(1)** and rear sections **(2)**.

To install the weather stripping to the mounting plate components, position each component on a work surface so that the marked side of the mounting plate faces up. Remember that this will be the side of the mounting plate that will contact the vehicle bed once it is installed on the CBC and secured to the vehicle.

Position the mounting plate components as shown so that the left (driver) side mounting plate **(3)** which is labeled "ROADSIDE" is positioned on the **RIGHT** side of the work area and the right (passenger) side mounting plate **(4)** which is labeled "CURBSIDE" is positioned on the **LEFT** side of the work area. Remember that the mounting plate components are laid out upside down on the work area.

Remove the protective backing **(6)** from the 3/16 inch thick weather stripping **(7)** included with the installation kit and apply the adhesive side of the weather stripping on the mounting plate component as illustrated. An outline on the mounting plate shows where the weather stripping is to be applied. Sections of weather stripping should be cut and applied at a right angle whenever the weather stripping changes direction.

Continue applying the 3/16 inch weather stripping **(7)** until it has been applied to all mounting plate components.

Apply a layer of 1/8 inch weather stripping **(8)** on top of the 3/16 inch layer **(7)** already in place. Be sure to stagger the joints **(9)** so that joints on the 3/16 inch and 1/8 inch layers are not in the same location. Press all weather stripping firmly in place.

Apply a section of 3/16 inch thick weather stripping approximately 3-1/4 inches in length along each end **(5)** of each **side** mounting plate section. This weather stripping will seal the areas where the side sections butt up against the front and rear mounting plate sections when they are installed on the CBC.

**CARGO BED COVER (CBC), TYPE III, 2 1/2 T CARGO TRUCK, LMTV, AND LMTV TRAILER 0015 00  
UNIT MAINTENANCE**

**NOTE:** This illustration depicts the **UNDERSIDE** of the mounting plate. This is the side that contacts the vehicle bed once the mounting plate is installed on the CBC.

Remember that the mounting plate is positioned **UPSIDE DOWN** on the work surface in order to apply weather stripping. The two side mounting plates are arranged on the work surface opposite their final installed positions on the CBC.

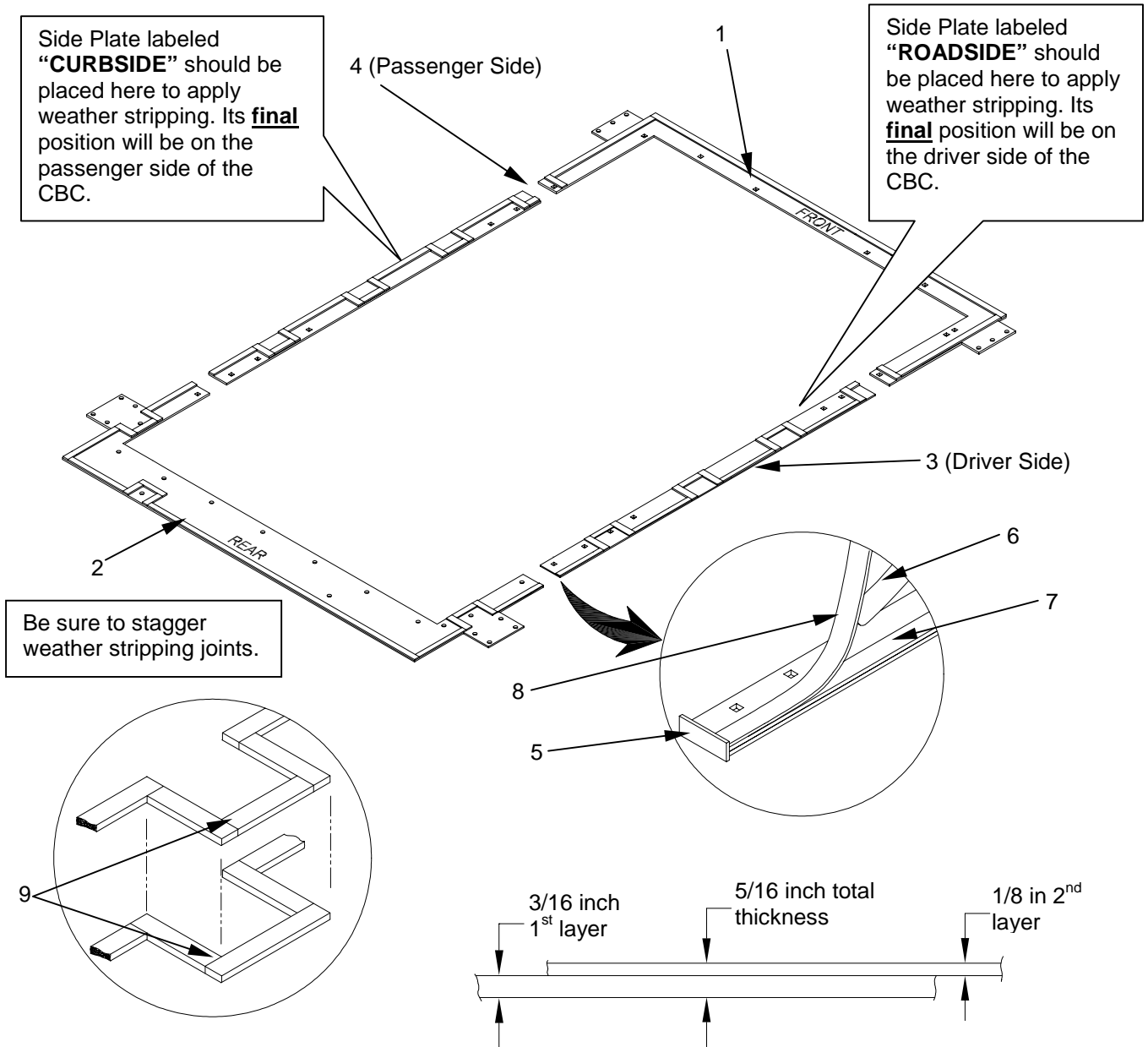

**CARGO BED COVER (CBC), TYPE III, 2 1/2 T CARGO TRUCK, LMTV, AND LMTV TRAILER 0015 00  
UNIT MAINTENANCE**

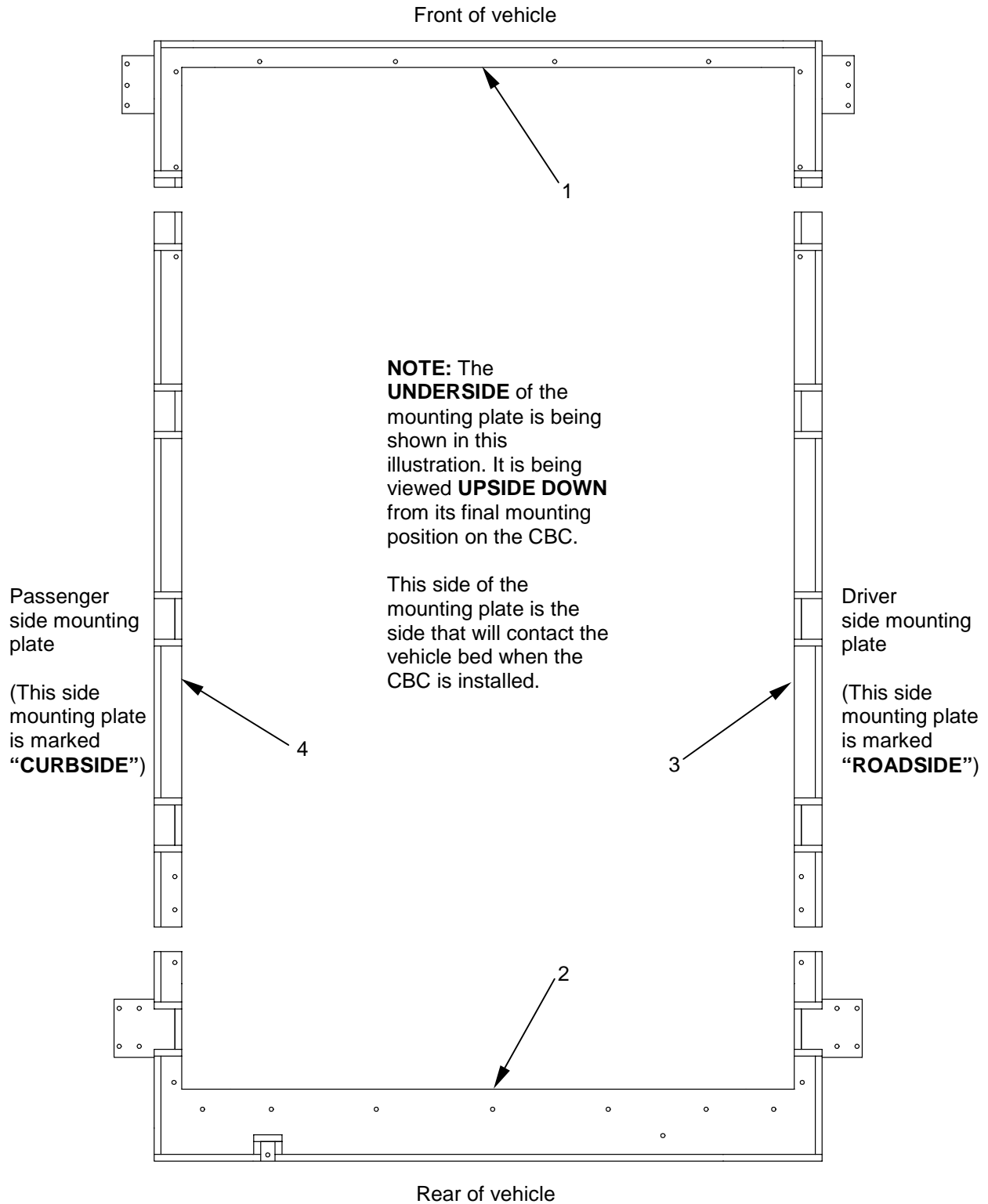

**CARGO BED COVER (CBC), TYPE III, 2 1/2 T CARGO TRUCK, LMTV, AND LMTV TRAILER 0015 00  
UNIT MAINTENANCE**

**MOUNT GUSSET PLATES TO FRONT MOUNTING PLATE**

Once the weather stripping has been applied to the underside of all four mounting plates, flip all four plates over on the work surface so that the weather stripping applied earlier now faces down on the work surface.



**NOTE**

Flat side of gusset plates face toward outside of trailer.

Align the spacer plate (1) with the front mounting plate (2) and install three 1.12 inch countersink screws (3). Install the left gusset plate (4) and attach it using 5/16" flat washers (5) and 5/16" locknut (6). Repeat this procedure for installing the right gusset plate. Tighten all hardware securely.

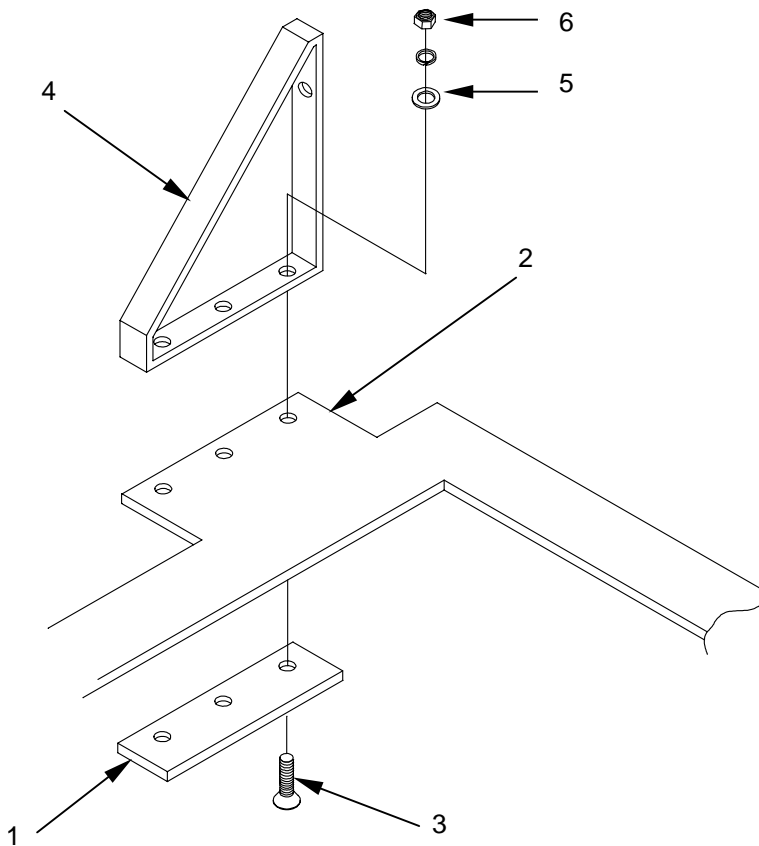



**CARGO BED COVER (CBC), TYPE III, 2 1/2 T CARGO TRUCK, LMTV, AND LMTV TRAILER 0015 00  
UNIT MAINTENANCE**

**INSTALLING THE MOUNTING PLATE TO THE CARGO BED COVER**

The mounting plate assembly mounts to the carrier mounting angles located at the bottom of the lower section of the CBC. The individual sections are secured to the carrier mounting angles using carriage bolts, pan head screws, flat washers, lock washers, and nuts that are supplied with the mounting plate installation kit.

**Installing the front mounting plate section.** Before installing the front and rear mounting plate sections, be sure that the supporting blocks are located under the side walls of the CBC and are approximately 24 inches from the corners. This will provide adequate room to install the front and rear sections.

To install the front mounting plate section (1) to the CBC (2), position the section under the front carrier mounting angle (3) of the CBC so that the face of the mounting plate section with the applied weather stripping faces DOWN and toward the vehicle bed.

Press the mounting plate (1) up into position and align the holes (4) on the mounting plate with the holes (5) on the carrier mounting angles (3).

Have a second person hold the mounting plate section (1) securely in position and install a total of eight 5/16-18 UNC x 1 inch long carriage bolts (6) up through the mounting plate (1) and through the CBC carrier mounting angle (3). Install one 5/16 inch flat washer (7) over the end of the bolt and against the surface of the carrier mounting angle, followed by a 5/16 inch lockwasher (8) and 5/16 UNC hex nut (9). Repeat for all remaining carriage bolts.

Hand tighten all hardware; do not tighten securely at this time.

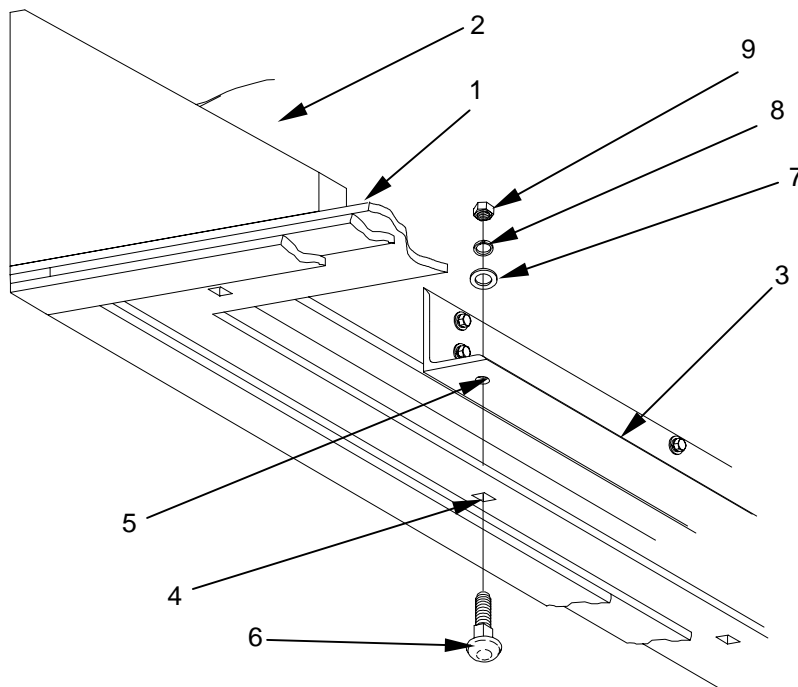

**CARGO BED COVER (CBC), TYPE III, 2 1/2 T CARGO TRUCK, LMTV, AND LMTV TRAILER 0015 00  
UNIT MAINTENANCE**

**Installing the rear mounting plate section.** To install the rear mounting plate section **(1)** to the CBC, position the section under the threshold **(2)** of the CBC so that the face of the mounting plate section with the applied weather stripping faces DOWN and toward the vehicle bed.

Press the mounting plate up **(1)** into position and align the holes on the mounting plate with the holes in the threshold **(2)**. Align the holes at the ends of the rear mounting plate with the holes on the side wall carrier mounting angle sections nearest the corners of the CBC.

Have a second person hold the mounting plate section in position and install a total of four, 5/16-18 UNC x 1 1/4 inch long carriage bolts **(3)** up through the mounting plate and the holes in the CBC threshold on either side of the personnel door opening. Install one 5/16 inch flat washer **(4)** over the end of the bolt and against the surface of the threshold **(2)** followed by a 5/16 inch lockwasher **(5)** and 5/16 UNC hex nut **(6)**.

Install four, 5/16-18 UNC x 1 inch long carriage bolts **(7)** up through the ends of the rear mounting plate **(1)** and the holes in the CBC carrier mounting angles along the side walls nearest the corners. Install one 5/16 inch flat washer **(8)** over the end of the bolt and against the surface of the carrier mounting angle followed by a 5/16 inch lockwasher **(9)** and 5/16 UNC hex nut **(10)**.

Install three, 5/16-18 UNC x .63 inch long pan head screws **(11)** DOWN through the section of the CBC threshold at the door opening and into threaded inserts **(12)** mounted in the mounting plate with a 5/16 inch lockwasher **(13)** under each head.

Hand tighten all hardware. Do not tighten securely at this time.

**Installing the left side (driver/roadside) mounting plate section.** Before installing the side mounting plate sections **(14,15)**, lift the CBC with the hoisting sling and reposition the supporting blocks under the front and rear mounting plate sections that were installed earlier. This will allow access to the side walls of the CBC.



**NOTE**

The holes for the side mounting plate sections may be partially obscured by the weather stripping installed earlier. To install the carriage bolt properly, move the weather stripping aside slightly to gain access to the hole. Install the carriage bolt so that it seats properly against the mounting plate. Make sure that the square portion under the head of the bolt fits into the square hole of the mounting plate. Reposition the weather stripping over the head of the carriage bolt.

Install the left side mounting plate section **(14)** in the same fashion as for the front **(16)** and rear **(1)** sections. Be sure to butt the ends **(17)** of the side section having the additional sections of weather stripping against the end **(18)** of the front section **(16)** and rear section **(1)**.

Press the left side mounting plate section **(14)** up into position and align the holes **(19)** on the mounting plate with the holes **(20)** on the carrier mounting angles **(21)**.

**TM 10-5411-233-13&P**

---

**CARGO BED COVER (CBC), TYPE III, 2 1/2 T CARGO TRUCK, LMTV, AND LMTV TRAILER 0015 00  
UNIT MAINTENANCE**

---

Attach the mounting plate section with four 5/16-18 UNC x 1 inch long carriage bolts **(7)** up through the mounting plate **(14)** and the CBC carrier mounting angle **(21)**, and 5/16 inch flatwasher **(8)**, 5/16 inch lockwashers **(9)** and 5/16 inch hex nuts **(10)**.

Tighten all hardware by hand but do not tighten securely at this time.

Once all four sections of the mounting plate assembly have been installed, tighten all hardware securely.

**Installing the right side (passenger or curbside) mounting plate section.** Repeat procedure for the right side (passenger/curbside) mounting plate section as described previously for the left side (driver/roadside) mounting plate section.

**CARGO BED COVER (CBC), TYPE III, 2 1/2 T CARGO TRUCK, LMTV, AND LMTV TRAILER 0015 00  
UNIT MAINTENANCE**

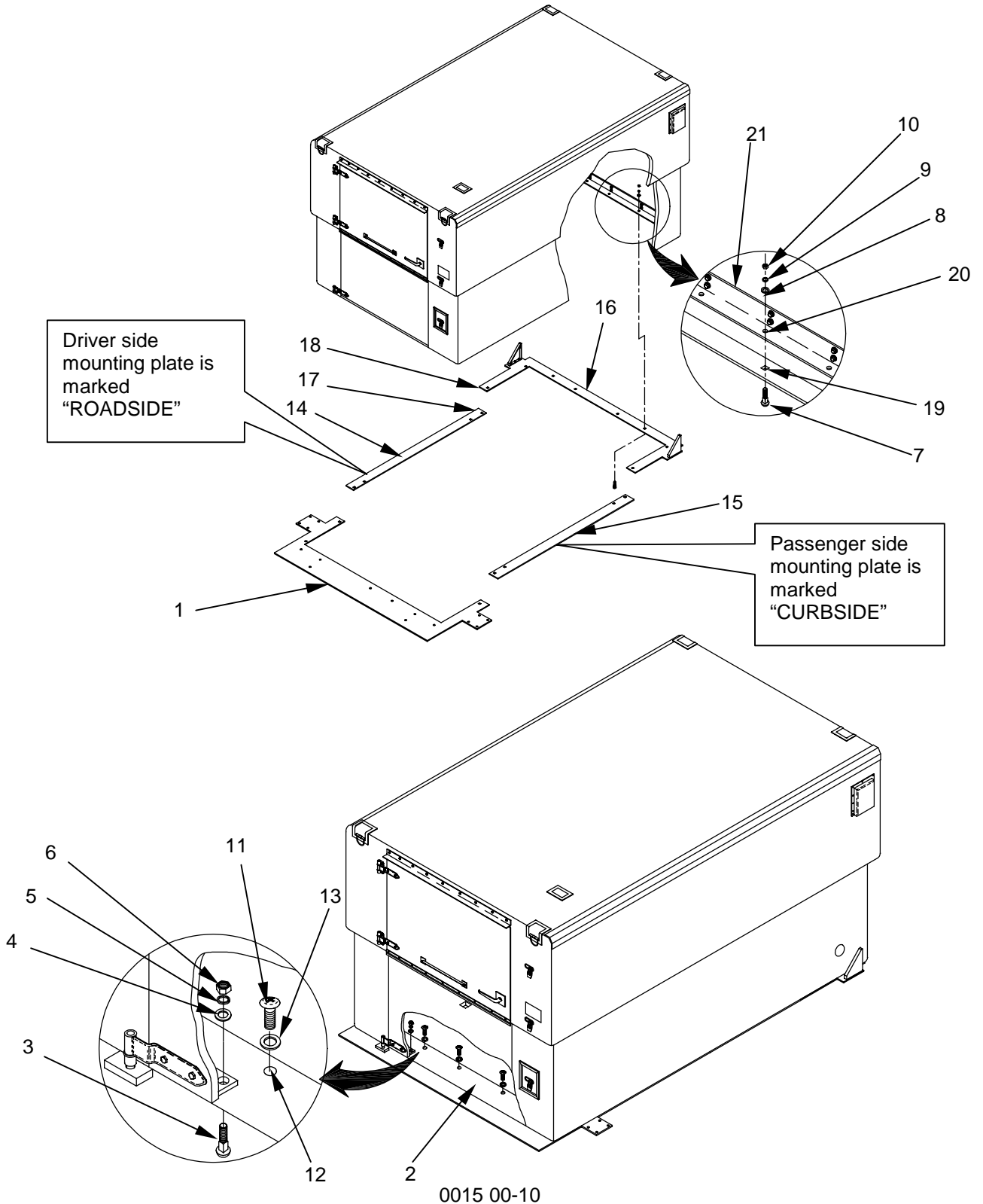

**INITIAL INSTALLATION OF CLAMP PLATE CHANNEL**

Before the CBC and mounting plate combination can be mounted to the vehicle bed, the clamp plate channel must be installed. Two clamp plate channels are installed on either side of the mounting plate assembly and secure the CBC/mounting plate combination to the vehicle bed.

To complete the initial installation of the clamp plate assembly, position one clamp plate assembly spacer plate (1) on the underside of the extension (2) that extends from the side of the rear mounting plate section (3). Be sure to position the spacer plate with the countersunk holes side facing down. Align the holes (4) in the spacer plate (1) with the holes (5) in the mounting plate extension (2).

Position the clamp plate channel (6) as shown on the top surface of the mounting plate extension (2), aligning the four holes (7) in the clamp plate channel (6) with the four holes (5) in the mounting plate extension (2).

Install the spacer plate (1) and clamp plate channel (6) in position on the mounting plate extension (2), install a 5/16-24 UNF x 1.28 inch long flat head screw (8) up through the spacer plate (1), mounting plate extension (2), exiting the top of the clamp plate channel (6).

Secure the screw (8) with one 5/16 inch flat washer (9), and 5/16 inch UNF hex locknut (10). Install the remaining three flat head screws and associated hardware. Tighten all hardware securely.

Repeat for the remaining clamp plate channel location.

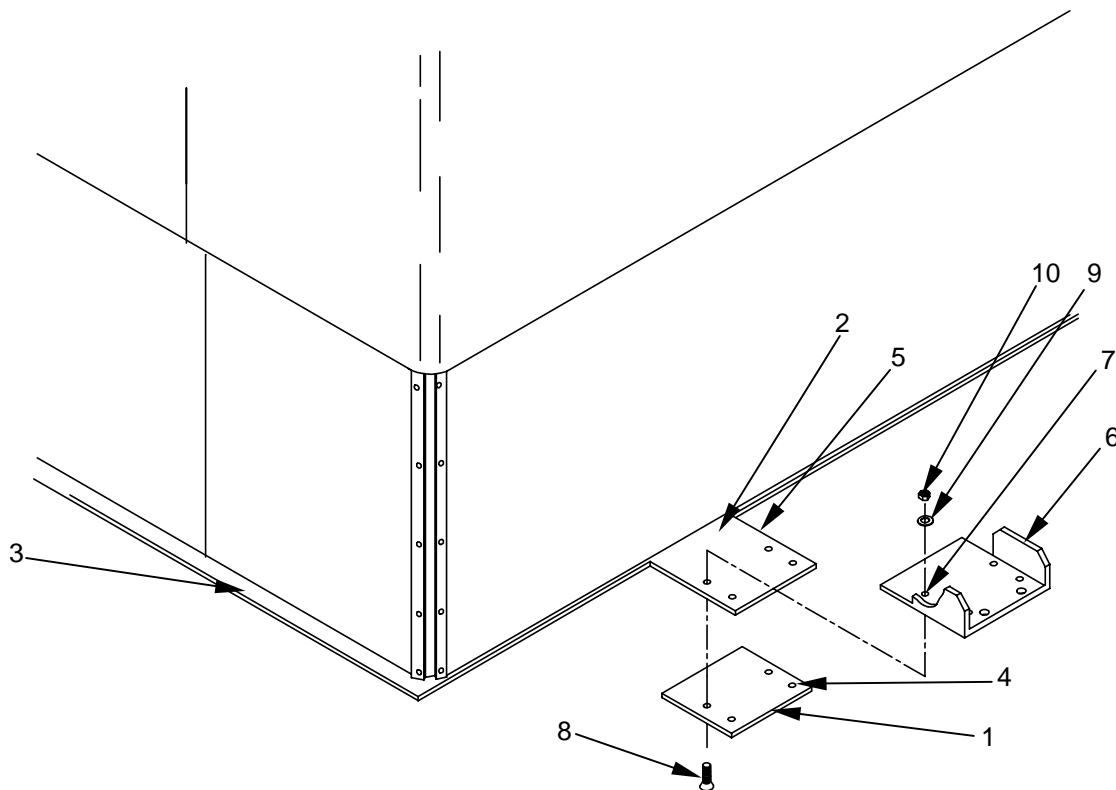

**CARGO BED COVER (CBC), TYPE III, 2 1/2 T CARGO TRUCK, LMTV, AND LMTV TRAILER 0015 00  
UNIT MAINTENANCE**

**LOWERING THE CBC ONTO THE VEHICLE BED**

Once the mounting plate assembly (1) has been completely installed on the bottom of the Cargo Bed Cover (2), the CBC can be carefully lowered onto the vehicle bed (3).

To install the CBC and mounting plate combination on the vehicle bed of the LMTV Trailer, lift the CBC off the shipping pallet using the hoisting sling (4) and slowly lower it into position on the bed of the LMTV Trailer. Lower the CBC/mounting plate combination until it is just above the surface of the vehicle bed.

Align the hole (5) in the vertical portion of each gusset plate (6) with the slotted hole (7) in the vertical trailer support (8) at the front of the trailer bed. Once the holes (5) on both gusset plates (6) are aligned properly and the vertical portion of the gusset plates (6) contact the vertical trailer supports (8) on each side of the trailer, lower the CBC until it completely rests on the trailer bed.

Install one 7 inch bolt (9) and flat washer (10) through slotted holes (7) in the vertical trailer support (8) and then through each gusset plate (6). Install a flat washer (10) through the hole (5) in the gusset plate (6) and through both slotted holes (7) in the vertical trailer support (8). Install a flat washer (10) and locknut (11) on the end of the 7 inch bolt (9) and hand tighten. Make sure there are no gaps between the gusset plate (6) and the vertical trailer support (8). Do not tighten the hardware securely at this time.

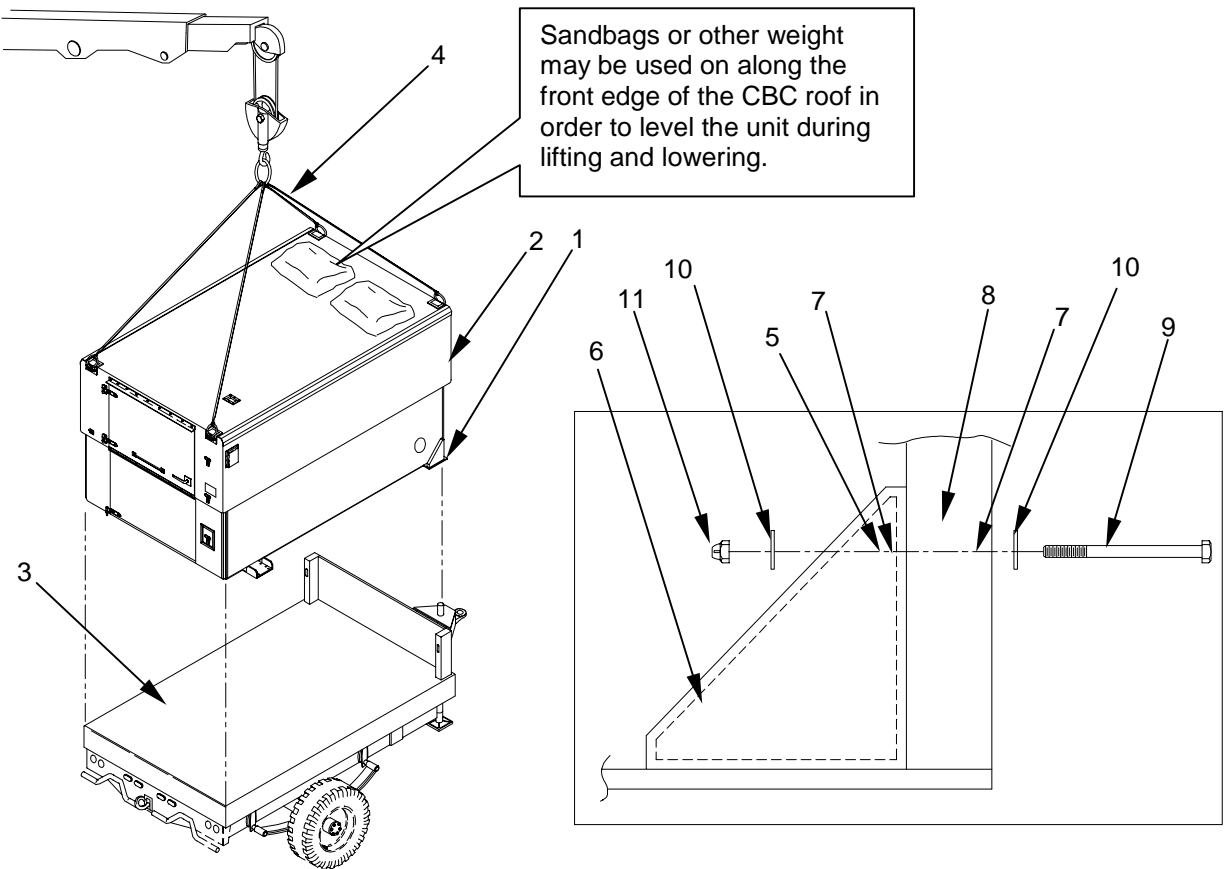

---

**CARGO BED COVER (CBC), TYPE III, 2 1/2 T CARGO TRUCK, LMTV, AND LMTV TRAILER 0015 00  
UNIT MAINTENANCE**

---

**IDENTIFYING GAPS BETWEEN THE CBC AND THE VEHICLE BED**

Once the CBC is in its final mounting position on the vehicle bed, the weather stripping seal must be inspected in order to detect any gaps that may exist between the weather stripping **(1)** on the underside of the mounting plate and the vehicle bed **(2)**. These gaps are typically caused by dents and other irregularities in the surface of the vehicle bed.

To inspect the quality of the weather stripping seal, have a person with a flashlight enter the CBC, partially close the personnel door, and shine the light along the bottom of the mounting plate where the weather stripping and vehicle bed meet.

On the outside of the CBC, use chalk, masking tape, or other temporary marking instrument, and mark those areas of the CBC where light shines through and gaps can be seen. To inspect the quality of the weather stripping seal at the front of the CBC, it will be necessary to enter the CBC and conduct the inspection from the inside.

Estimate the width of each gap area in order to determine whether 3/16 inch or 1/8 inch weather stripping is required to properly fill the gap. Make a note of the thickness required with chalk or on a piece of masking tape placed in the area of the gap. Note that in some cases it may be necessary to use some combination of both sizes of weather stripping in order to properly close the gap.

Once the gaps have been identified and marked, remove the two bolts temporarily securing the gusset plates and raise the CBC using the hoisting sling to a comfortable working height and apply additional weather stripping in the marked areas.

When the additional weather stripping has been installed, lower the CBC back into position on the vehicle bed. Inspect the quality of the seal using the method described above. If any gaps are still seen, mark the areas and apply additional layers of weather stripping as required.

Continue this process until no gaps are present. Do not secure the CBC to the vehicle bed at this time.

CARGO BED COVER (CBC), TYPE III, 2 1/2 T CARGO TRUCK, LMTV, AND LMTV TRAILER 0015 00  
UNIT MAINTENANCE

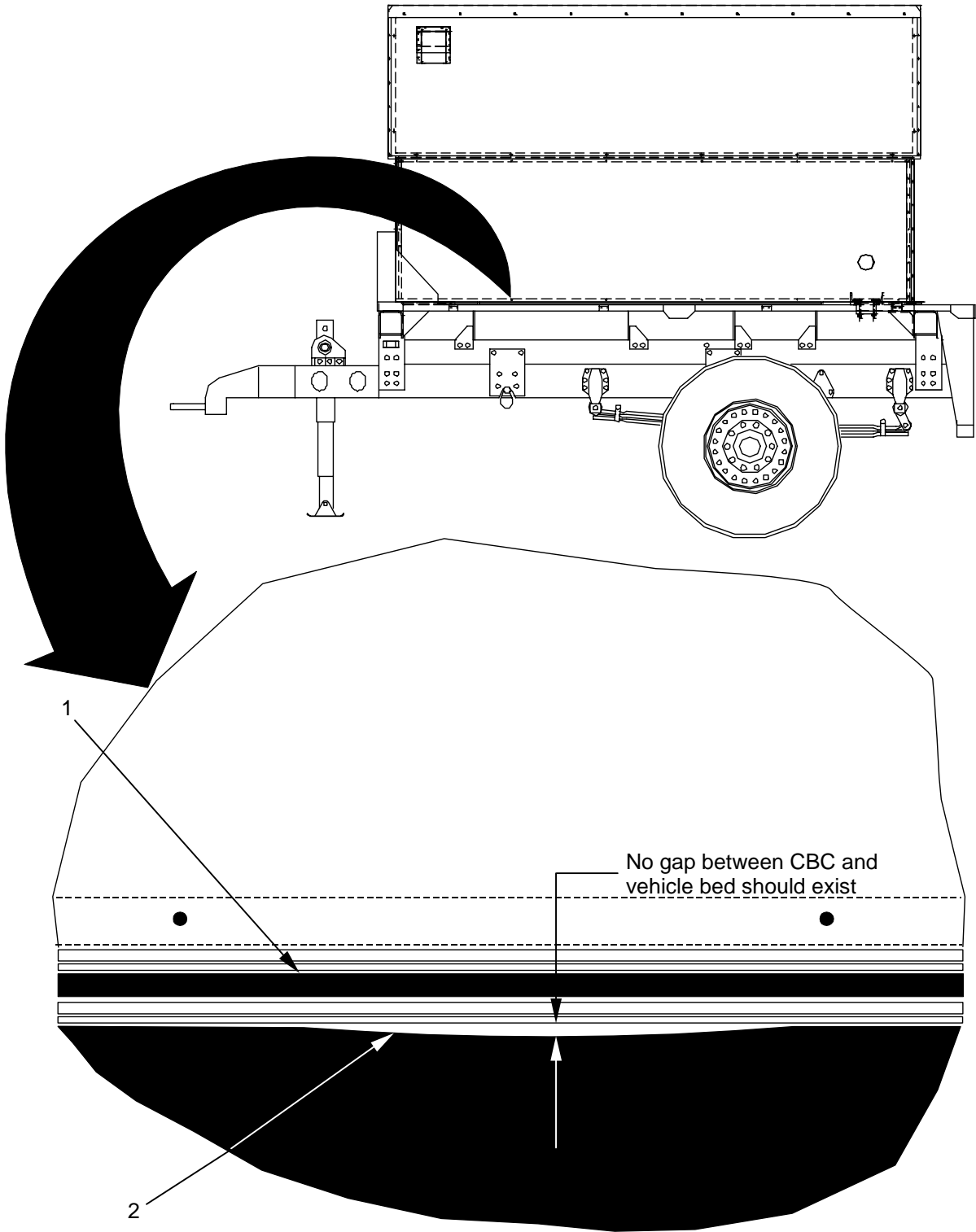



APPLYING RTV SILICONE SEALANT, FINAL ASSEMBLY OF GUSSET PLATES



NOTE

Sealant should be applied only if the CBC is to be immediately mounted to the vehicle bed. The sealant has a working time of approximately 20 minutes and will start to cure after that time. Installing the CBC on the vehicle after the sealant begins to cure may adversely affect the sealant's ability to properly bond with the vehicle bed.

Once all gaps have been identified and eliminated as described above, a bead of RTV (silicone) sealant must be applied where the weather stripping contacts the vehicle bed and around the threshold area.

To apply the RTV sealant, raise the CBC to a comfortable working height using the hoisting sling.

Install the supplied cartridge of sealant into a standard caulking gun. Trim the tip of the cartridge so that a bead approximately 3/16 to 1/4 inch in width can be applied.

Apply a continuous bead of sealant **(1)** 3/16 to 1/4 inch in width on the surface of the weather stripping **(2)** along the outer edge. Start at one point at the underside of the CBC and move around the entire perimeter of the CBC applying sealant to all weather stripping surfaces.

Once sealant has been properly applied to all weather stripping surfaces, the CBC should be lowered into position on the vehicle bed. Take care to return the CBC in the same position so that the hole in the gusset plates align with the slotted hole in the vertical trailer support and that the flat portion of the gusset plate contacts the vertical trailer support.

Install one 7 inch bolt **(3)** and flat washer **(8)** through both slotted holes **(6)** in the vertical trailer support **(7)**. Install a flat washer **(8)** and locknut **(9)** on the end of the 7 inch bolt **(3)**. Tighten the hardware on each gusset plate securely.

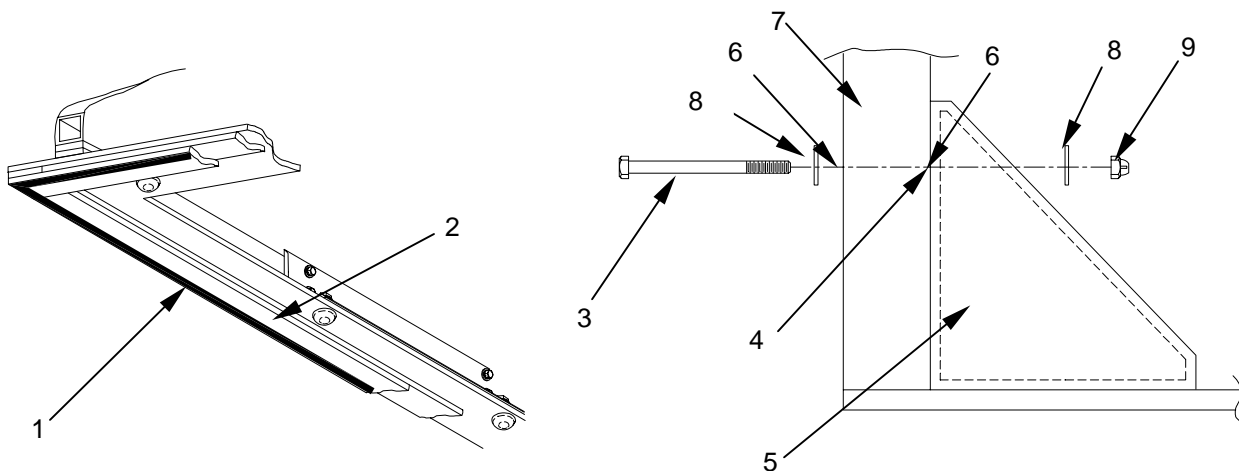

**CARGO BED COVER (CBC), TYPE III, 2 1/2 T CARGO TRUCK, LMTV, AND LMTV TRAILER 0015 00  
UNIT MAINTENANCE**

RTV sealant must now be applied around the threshold area (1) at the rear of the CBC.

To apply sealant around the threshold area, start at the left corner (2) of the CBC and inject sealant (3) under the area where the threshold (1) meets the mounting plate (4). Fill the area sufficiently to create a good weather seal.

Continue to apply a bead of sealant all along the edge of the threshold (1) at the point where it meets the mounting plate (4). Be sure to apply sealant around the hinge pivot pin area (5). Continue around the right corner (6) of the CBC and inject sealant under the right side of the threshold (7) as was done with the left corner.

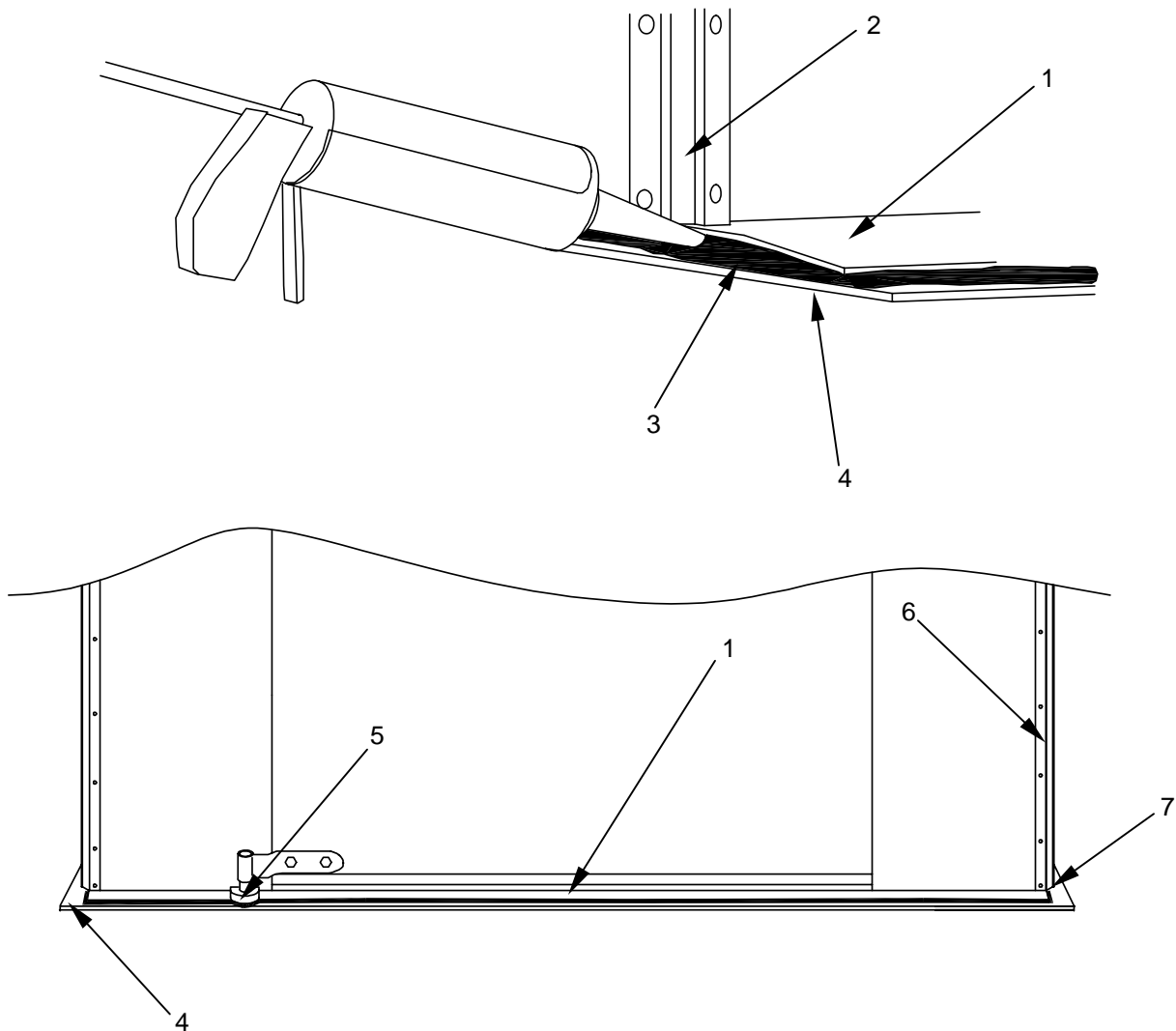

---

**CARGO BED COVER (CBC), TYPE III, 2 1/2 T CARGO TRUCK, LMTV, AND LMTV TRAILER 0015 00  
UNIT MAINTENANCE**

---

**FINAL INSTALLATION OF CLAMP PLATE ASSEMBLY**

Two clamp plate assemblies **(1)** (one on each side) are installed at the corners of the rear mounting plate assembly **(2)** and are used to secure the CBC/mounting plate combination **(3)** to the trailer bed **(4)**.

With the CBC is in its final position, position the spacer **(5)** and bottom plate with rubber pad **(6)** under the installed portion of the clamp plate assembly **(7)** located at the rear passenger side **(8)**.

Install a hex head bolt **(9)** through each hole in the clamp plate channel **(10)**, spacer **(5)**, and bottom plate with rubber pad **(6)**. Make sure that the rubber pad on the bottom plate **(6)** faces up and engages securely on the underside of the trailer bed **(4)**.

Secure the assembly with 1/2 inch flat washer **(11)**, and 1/2-13 UNC locknut **(12)** Tighten the clamp plate assembly hardware securely.

Repeat the above procedure for the clamp plate assembly located on the rear driver side of the CBC. Tighten the clamp plate assembly hardware securely.

Once the CBC has been securely installed to the vehicle, the Cargo Bed Cover is ready to be used as detailed in WP 0005 entitled "OPERATION UNDER USUAL CONDITIONS".

**MODIFYING THE LMTV TRAILER LADDER**

The ladder that is supplied with the LMTV Trailer must be modified to permit clearance of the CBC personnel door and the ladder. To modify the ladder, 5 inches of the top left leg must be cut off. Once the top of the left leg has been shortened, the cut end should be protected with a plastic cap.

CARGO BED COVER (CBC), TYPE III, 2 1/2 T CARGO TRUCK, LMTV, AND LMTV TRAILER 0015 00  
UNIT MAINTENANCE

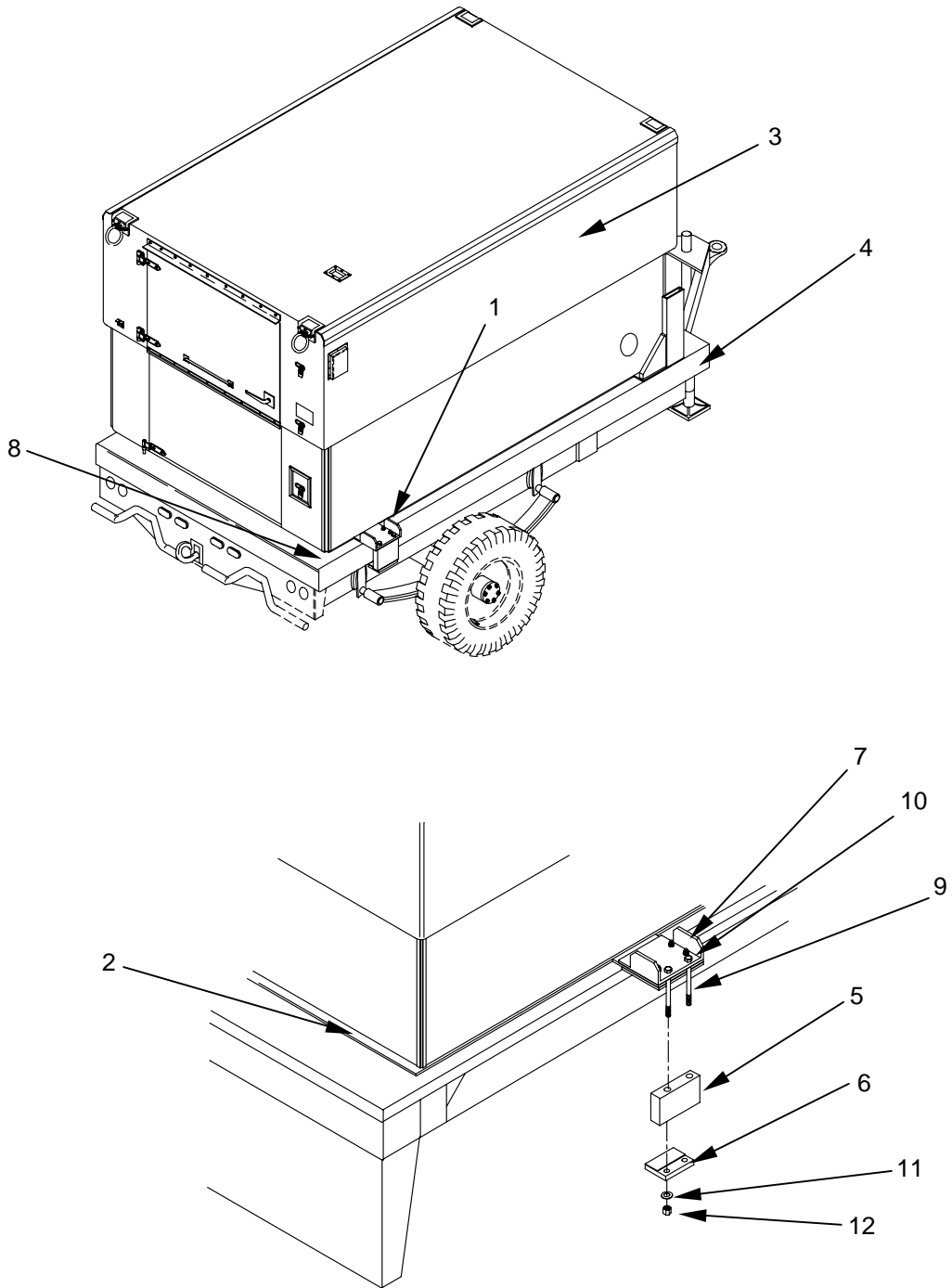

END OF WORK PACKAGE

**CARGO BED COVER (CBC), TYPE III, 2 1/2 T CARGO TRUCK, LMTV, AND LMTV TRAILER 0016 00 UNIT MAINTENANCE**

**LADDER INSTALLATION**

**THIS SECTION COVERS:**

Installation

**INITIAL SETUP**

**Maintenance Level**

Unit

**Tools and Special Tools**

General Mechanic Tool Kit (WP 0041, Table 2, Item 1)

**Materials/Parts**

Light machine oil  
(WP0055, Table 1, Item 1)

**GENERAL**

Before the Cargo Bed Cover can be used, a ladder must be installed on the tailgate of the M35A2, 2 1/2 T Cargo Truck. The ladder is stowed on the inside, left hand surface of the tailgate (while standing and facing the rear of the vehicle). This installation only applies to the M35A2, 2 1/2 Ton Cargo Truck. It is not required with the M1078, 2 1/2 Ton LMTV or M1082, 2 1/2 Ton LMTV Trailer.

In order to install the ladder (1), a set of stowage brackets (2) must be installed on the left hand, inside surface of the tailgate (3). Two strap assemblies (4) are also installed on the inside surface of the tailgate. The combination of stowage brackets (2) and strap assemblies (4) secure the ladder in its stowed position.

A set of deployment brackets (5) is installed toward the rear, right hand edge of the tailgate (3). These deployment brackets are used to support the ladder in its deployed condition.

The installation process for the stowage brackets (2), deployment brackets (5), and strap assemblies (4) involve measuring and locating a series of holes on the tailgate, drilling out these holes, installing threaded inserts, and mounting the various brackets.

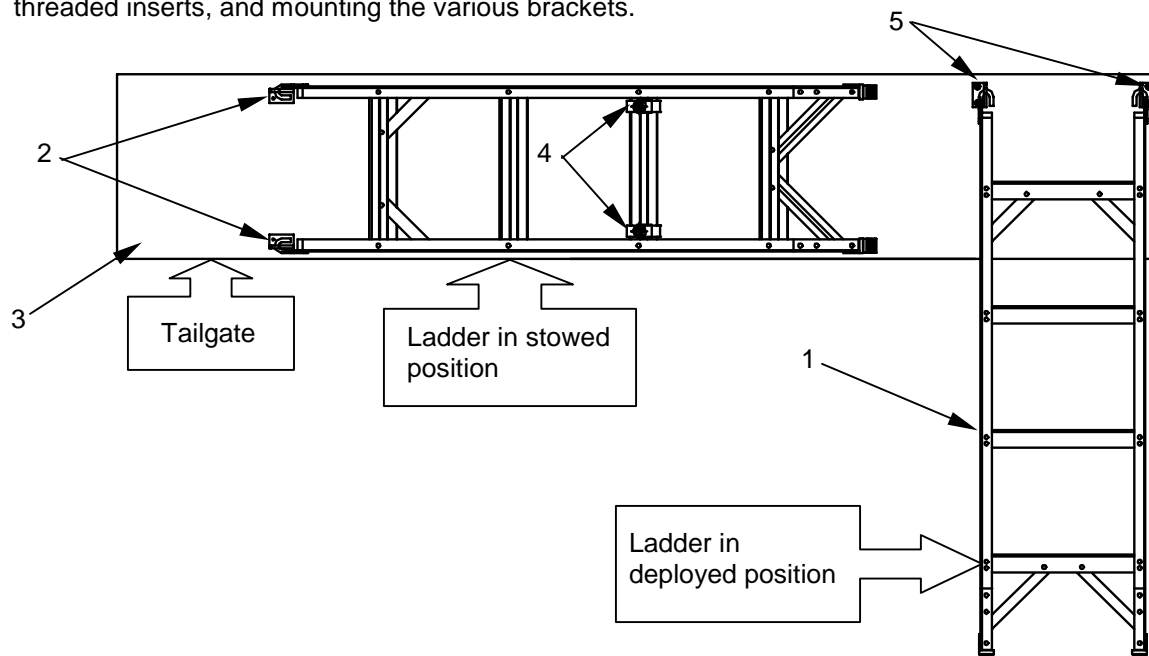

**TM 10-5411-233-13&P**

**CARGO BED COVER (CBC), TYPE III, 2 1/2 T CARGO TRUCK, LMTV, AND LMTV TRAILER 0016 00  
UNIT MAINTENANCE**

**LADDER INSTALLATION PROCEDURE**

To install the ladder hardware for the 2 1/2 Ton Cargo Truck, lower the tailgate and lock it into a horizontal position. This creates a convenient and stable work surface for the installation process.

**Ladder Installation Kit Contents.** Table 1 lists the parts contained within the ladder installation kit. Verify that all parts are present and in the proper quantity. Arrange the parts on a convenient worksurface near the tailgate of the vehicle.

Table 1. Parts Listing Entry Ladder Kit for M35A2

ITEM NO.	PART NUMBER	DESCRIPTION AND USABLE ON CODE	QTY
1	17-1-0315	LADDER, VEHICLE .....	1
2	17-1-0315-2	BRACKET, ANGLE .....	1
3	17-1-0315-3	BRACKET, ANGLE .....	1
4	17-1-0315-4	BRACKET, ANGLE .....	1
5	17-1-0315-5	BRACKET, ANGLE .....	1
6	S25B140	BLIND RIVNUT (1/4-20) .....	10
7	17-1-3618-1	STRAP, HANDLE.....	2
8	AN970-4	WASHER, FLAT (1/4) .....	4
9	MS35338-139	WASHER, LOCK (1/4) .....	8
10	ASME 18.2.1	SCREW, HEX HD (1/4-20 X .75 LG) .....	10
11	C-845	WRENCH TYPE HEADER (1/4-20).....	1
12	3374A25	9/32 TRANSFER PUNCH .....	1
13	2932A28	DRILL BIT (LET Q).....	1
14	2521A622	HAND TAP (1/4-20).....	1

CARGO BED COVER (CBC), TYPE III, 2 1/2 T CARGO TRUCK, LMTV, AND LMTV TRAILER 0016 00  
UNIT MAINTENANCE

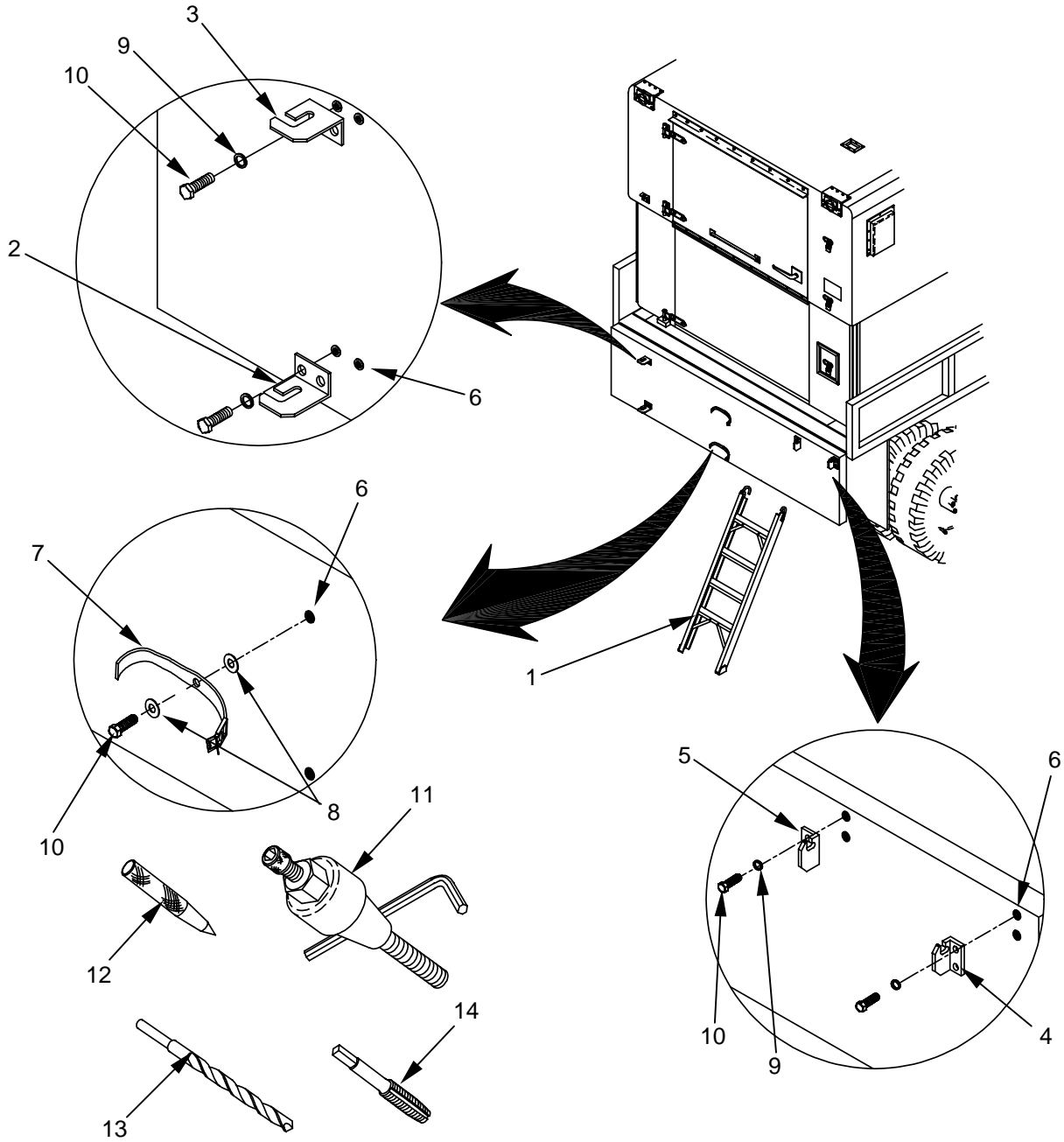

**CARGO BED COVER (CBC), TYPE III, 2 1/2 T CARGO TRUCK, LMTV, AND LMTV TRAILER 0016 00 UNIT MAINTENANCE**

**Tailgate Position References.** Throughout the procedures that follow, references will be made to the four edges of the tailgate. All positions are given from the perspective of a soldier standing and facing the rear of the vehicle with the tailgate down. The left, right, front, and rear edge of the tailgate are shown in the accompanying diagram.

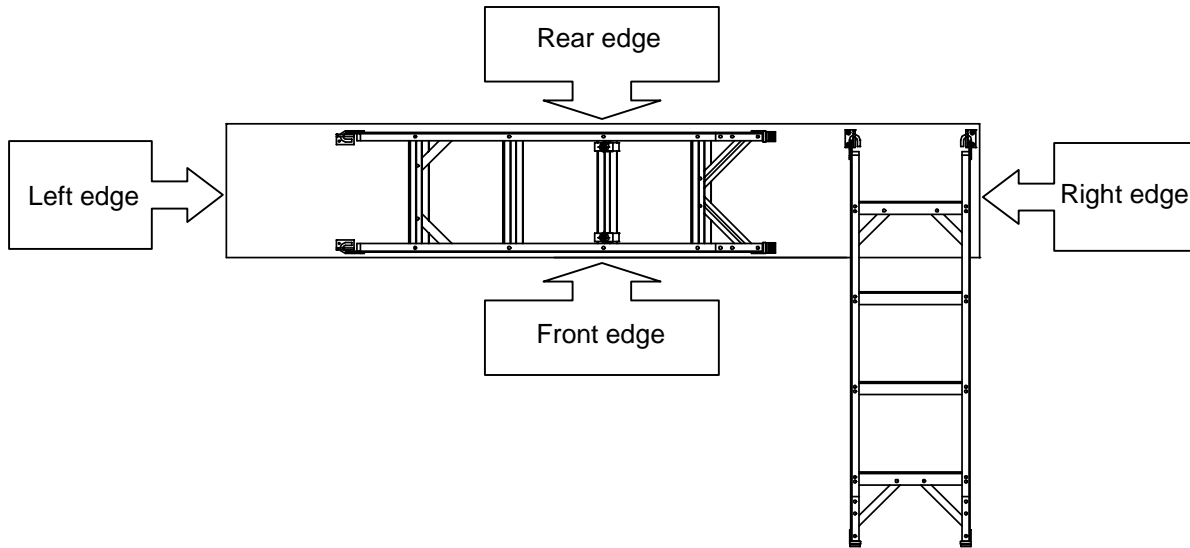

**Mounting the ladder stowage brackets**

**Step 1.** To install the ladder stowage brackets required to stow the ladder, use a tape measure and make a mark 14 inches in from the left edge of the tailgate at its front edge.

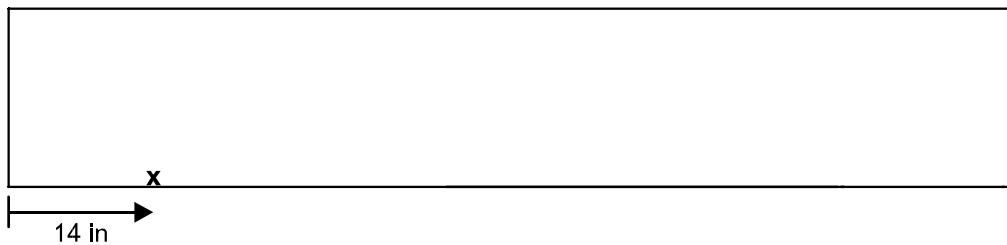

**Step 2.** At the 14 inch mark, draw a 2 inch vertical line from the front edge of the tailgate toward the rear edge of the tailgate.





**CARGO BED COVER (CBC), TYPE III, 2 1/2 T CARGO TRUCK, LMTV, AND LMTV TRAILER 0016 00  
UNIT MAINTENANCE**

**Step 3.** Measure 1 1/2 inches from the front edge of the tailgate along the 2 inch vertical line and make a mark.

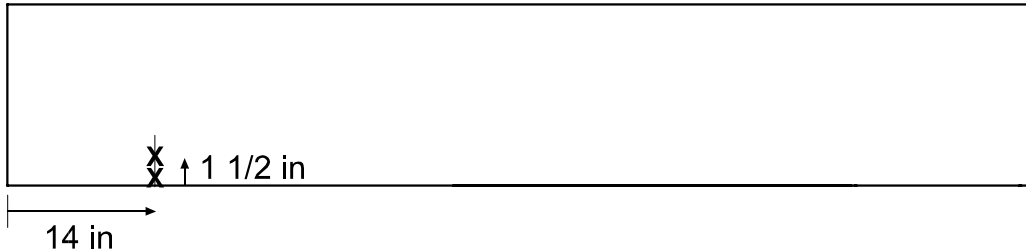

**Step 4.** Make a second mark approximately 3 inches to the right of the 1 1/2 inch mark and draw a line connecting the two marks with a straight edge.

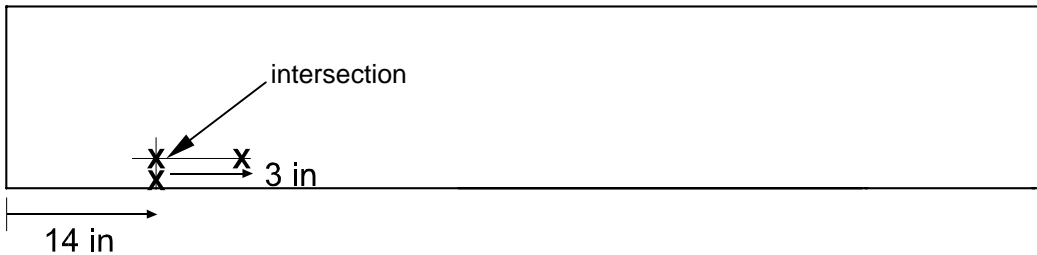

**Step 5.** Place the first bracket in position at the intersection point located 14 inches in from the left edge and 1 1/2 inches from the front edge of the tailgate. Be sure to select the larger "stowage" bracket as these brackets are different from the smaller "deployment" brackets. Position the bracket so that the mounting holes face the rear edge of the tailgate. Ensure that the opening on the bracket faces the left edge of the tailgate. Mark the position of the two holes in the first bracket.



**Step 6.** Using a 9/32 inch transfer punch, mark the center of the two mounting holes.



**CARGO BED COVER (CBC), TYPE III, 2 1/2 T CARGO TRUCK, LMTV, AND LMTV TRAILER 0016 00 UNIT MAINTENANCE**

**Step 7.** Using a Letter "Q" size drill bit, drill out the two marked holes. Drill only through the inside surface of the tailgate. Do not drill completely through the opposite side of the tailgate. Remove any burrs.



**Step 8.** Install a 1/4-20 blind Rivnut in each of the two mounting holes using a Rivnut installation tool included with the mounting kit. Complete instructions for Rivnut installation can be found in WP 0013.

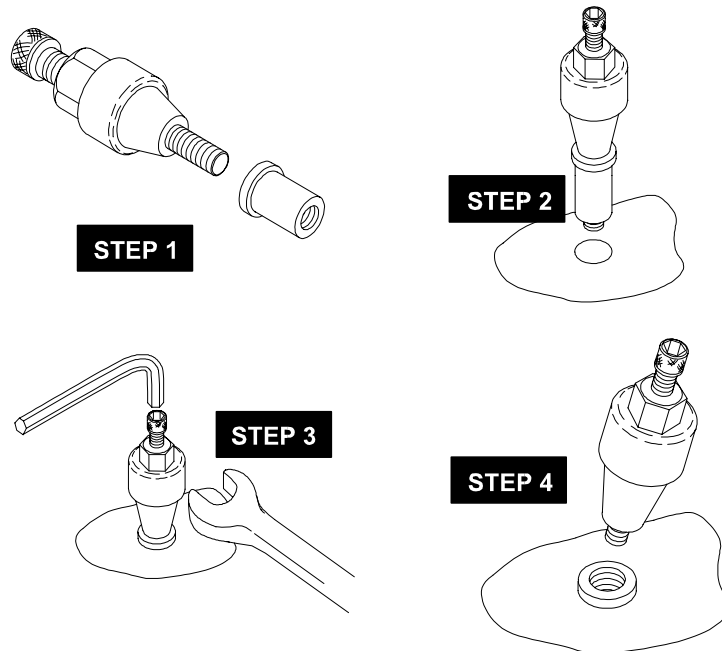

**Step 9.** Once all Rivnuts have been installed, mount the bracket to the tailgate using 1/4-20 x .75 inch long hex head screws and 1/4 inch lockwashers. Tighten all hardware securely.



**Step 10.** With the tailgate in a horizontal position, attach the ladder to the installed first bracket.

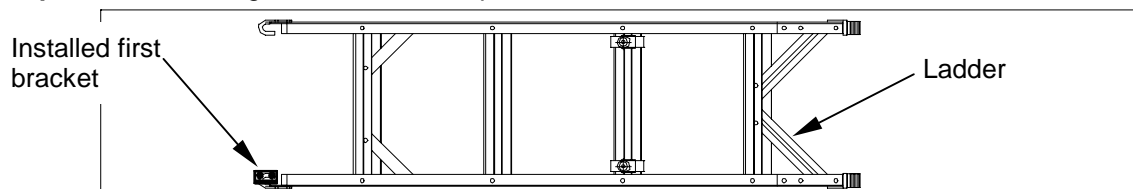

**CARGO BED COVER (CBC), TYPE III, 2 1/2 T CARGO TRUCK, LMTV, AND LMTV TRAILER 0016 00  
UNIT MAINTENANCE**

**Step 11.** Using the ladder as a “template”, attach the second uninstalled bracket to the opposite side of the ladder (I,e., opposite the installed bracket). Position the second uninstalled bracket so that the mounting holes face the first bracket and toward the front edge of the tailgate. Ensure that the opening on the bracket faces the left edge of the tailgate. Mark the position of the two holes in the second uninstalled bracket. Remove the ladder from the tailgate.

Uninstalled second bracket

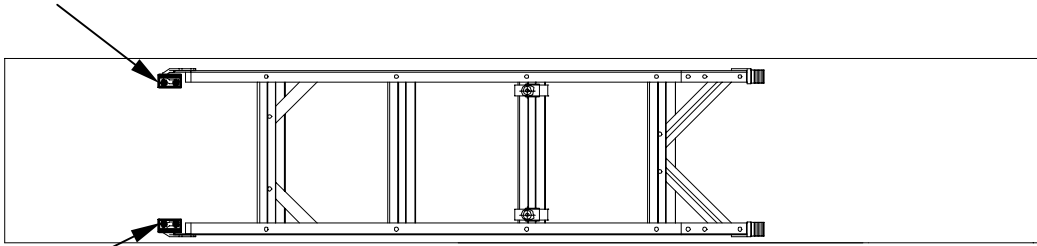

Installed first bracket

**Step 12.** Repeat prior **Steps 6** through **9** to complete installation of the second bracket.

**Mounting strap assemblies for ladder stowage**

**Step 1.** To install the two strap assemblies used to stow the ladder, use a tape measure and make a mark 48 1/4 inches from the left edge of the tailgate at its front edge.

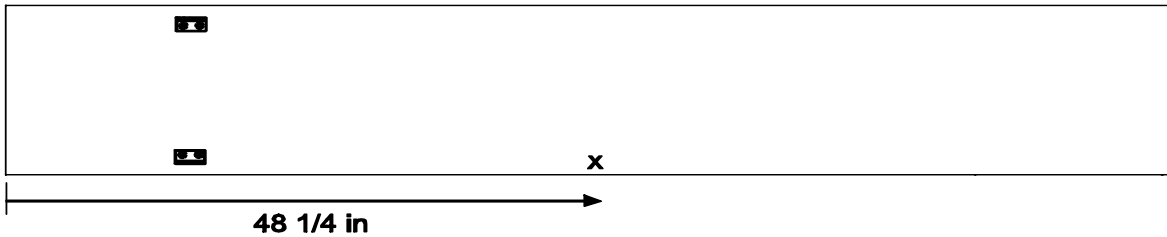

**Step 2.** Make a second mark 48 1/4 inches from the left edge, but approximately 15 inches back from the front edge.

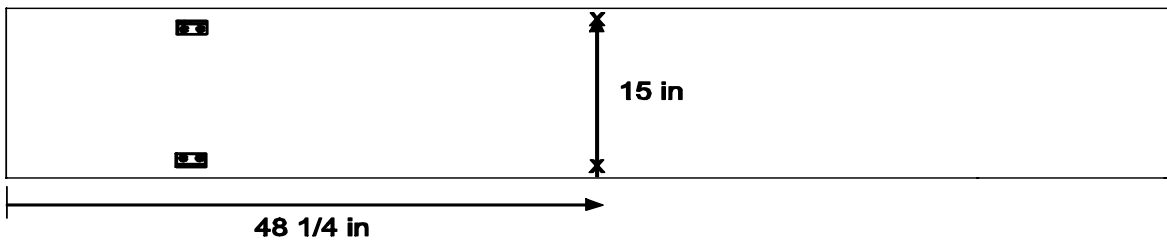

**CARGO BED COVER (CBC), TYPE III, 2 1/2 T CARGO TRUCK, LMTV, AND LMTV TRAILER 0016 00 UNIT MAINTENANCE**

**Step 3.** Draw a line connecting the two marks with a straightedge.

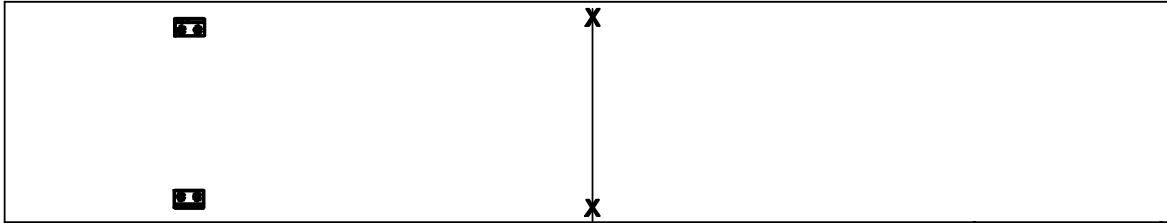

**Step 4.** Measure 3 inches from the front edge of the tailgate. Mark this point on the drawn line.

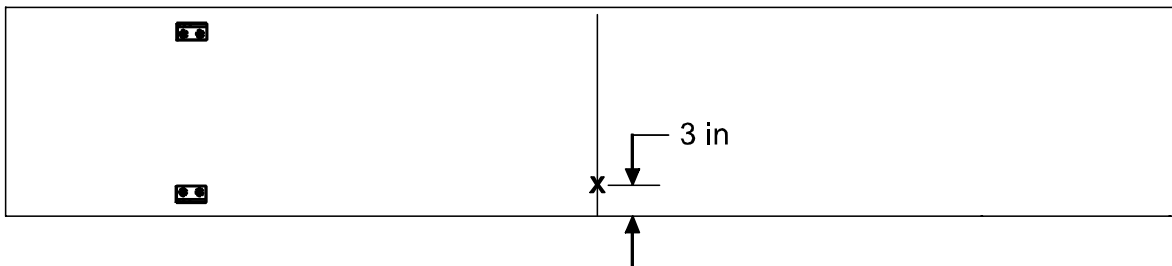

**Step 5.** Measure 14 1/2 inches from the front edge of the tailgate and mark a second point on the drawn line. These marked intersecting points define the attaching points of the two strap assemblies.

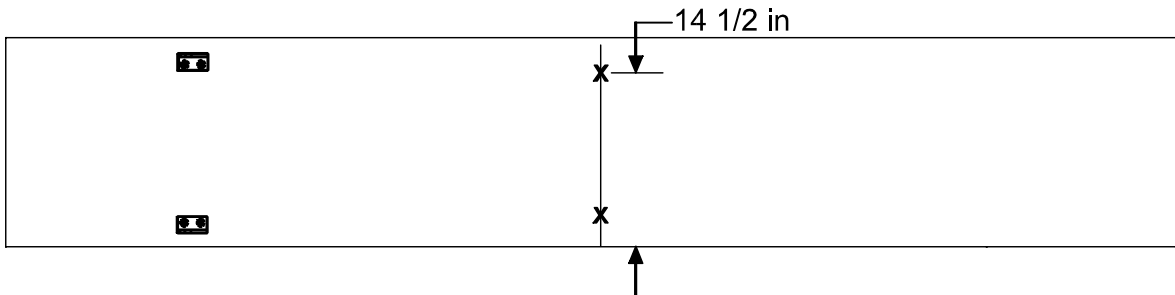

**Step 6.** Mark the center of each hole with the included transfer punch.

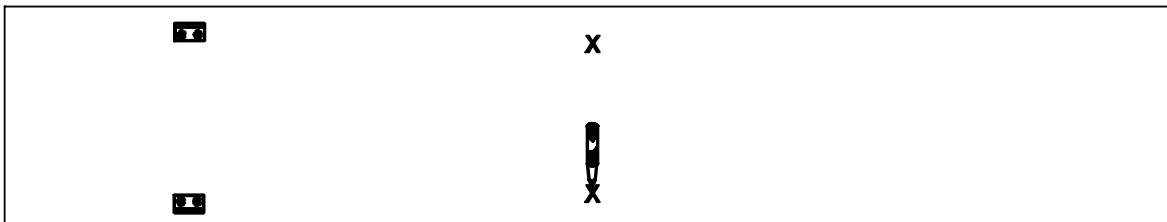

**Step 7.** Using a Letter "Q" size drill bit, drill out the two marked holes. Remove any burrs.

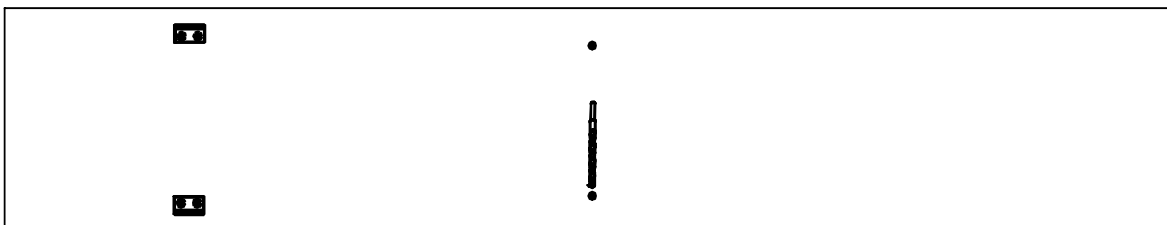

**CARGO BED COVER (CBC), TYPE III, 2 1/2 T CARGO TRUCK, LMTV, AND LMTV TRAILER 0016 00 UNIT MAINTENANCE**

**Step 8.** Install a 1/4-20 blind Rivnut in each mounting hole using the Rivnut installation tool included in the mounting kit. Install the Rivnut IAW instructions for Rivnut installation as detailed in WP 0013.

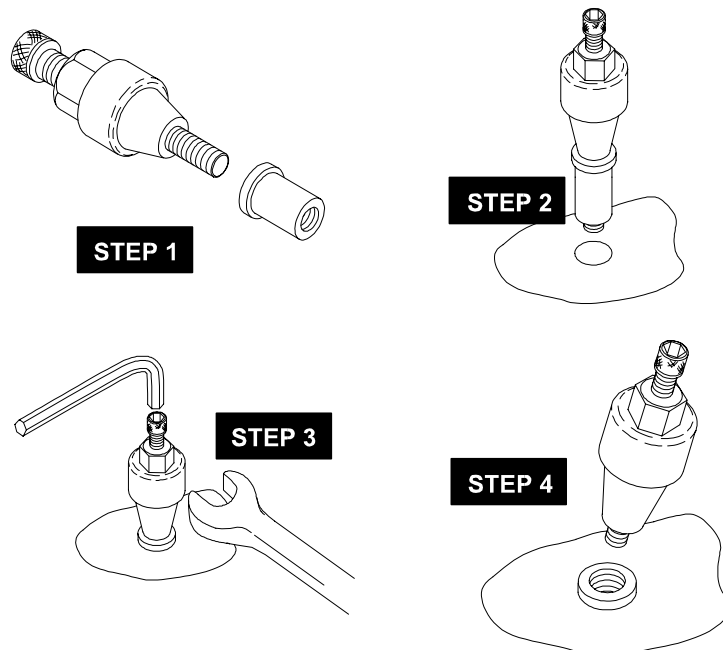

**Step 9.** Once both Rivnuts have been installed, align the mating attachment holes and mount the two strap assemblies so that their buckles face **away** from the left edge of the tailgate. Secure the strap assemblies to the tailgate using a 1/4-20 x .75 inch long hex head screws and two large (1 1/8 in OD) 1/4 inch flat washers. One flat washer should be on each side of the strap assembly, one under the screw head and a second between the strap and the tailgate. Tighten all hardware securely.

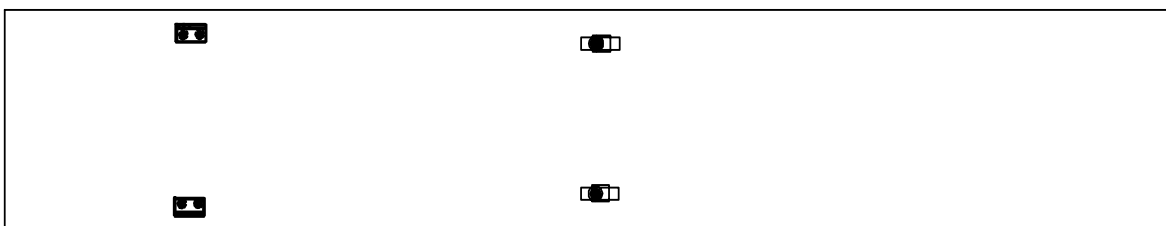

**Mounting ladder deployment brackets**

**Step 1.** To install the brackets required to deploy the ladder on the tailgate, use a tape measure and make a mark 14 inches from the front edge and along the right edge of the tailgate.

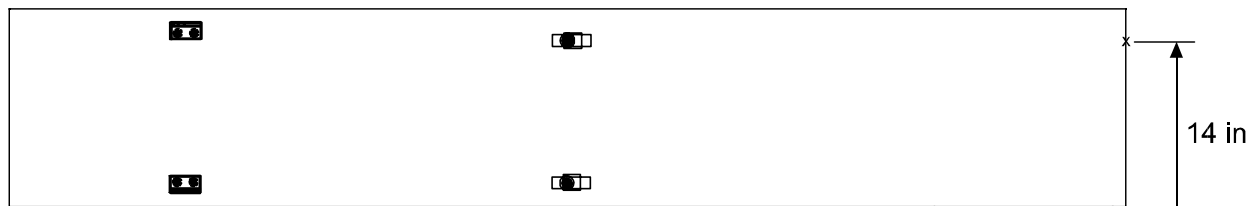

**CARGO BED COVER (CBC), TYPE III, 2 1/2 T CARGO TRUCK, LMTV, AND LMTV TRAILER 0016 00  
UNIT MAINTENANCE**

**Step 2.** At the 14 inch mark, draw a 3 inch horizontal line with a straightedge from the right edge of the tailgate extending toward the left edge of the tailgate.

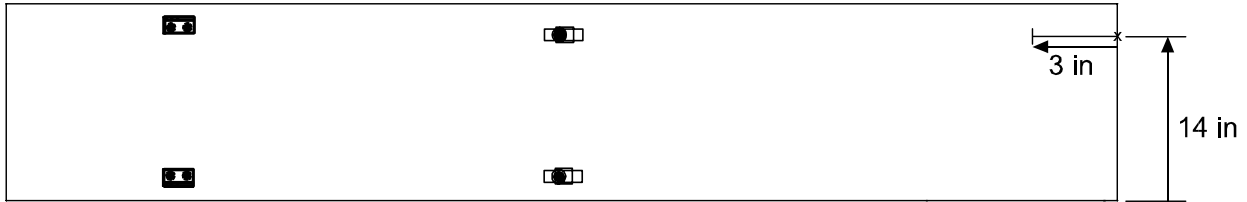

**Step 3.** Measure 1 inch in from the right edge of the tailgate. Mark this point on the drawn 3 inch line. Note that this point marks the outer corner of the first mounting bracket.

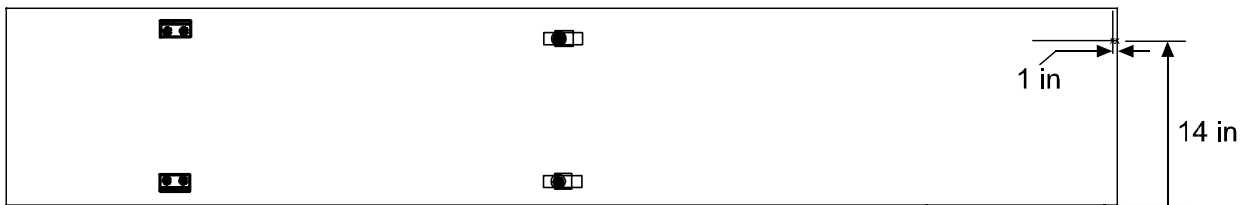

**Step 4.** Place the first bracket in position so that its outer edge lies on the line 1 inch in from the right edge of the tailgate. Be sure to use the smaller “deployment” bracket. The hooks on the bracket should face the hinge on the tailgate. Orient the mounting holes on the first bracket to face outward and toward the right edge of the tailgate. Mark the position of the two holes in the first bracket.

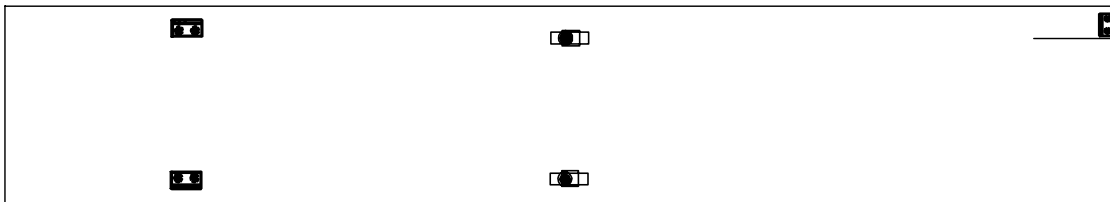

**Step 5.** Using the 9/32 inch transfer punch included with the mounting kit, mark the center of the two mounting holes. Be sure to get as close to the center as possible.

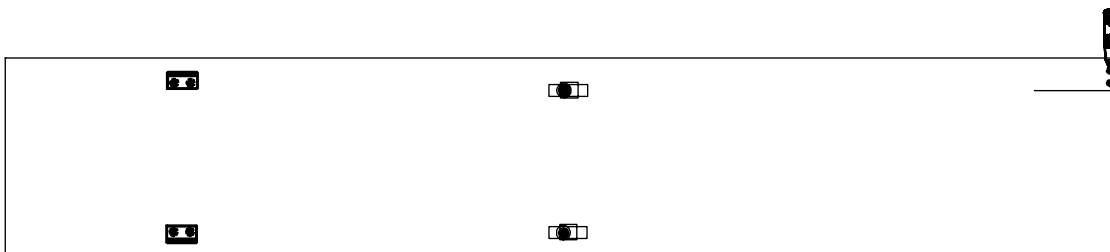

**CARGO BED COVER (CBC), TYPE III, 2 1/2 T CARGO TRUCK, LMTV, AND LMTV TRAILER 0016 00  
UNIT MAINTENANCE**

**Step 6.** Using a Letter "Q" size drill bit, drill out the two marked holes. Remove any burrs.

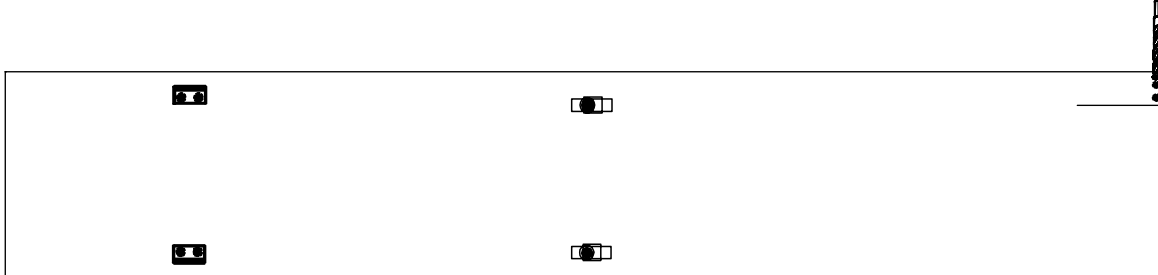

**Step 7.** Install a 1/4-20 blind Rivnut in each of the two mounting holes with a using a Rivnut installation tool. Install the Rivnut IAW the instructions for Rivnut installation found in WP 0013.

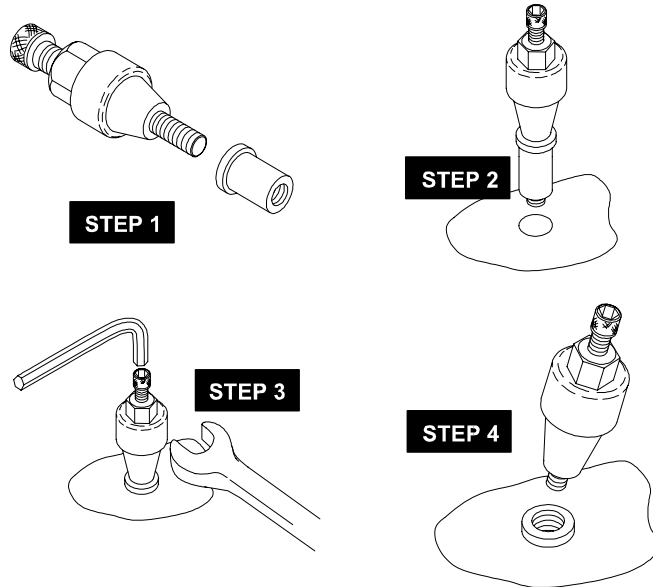

**Step 8.** Once all Rivnuts have been installed, mount the bracket with the hooks facing the rear edge of the tailgate using a 1/4-20 x .75 inch long hex head screw and 1/4 inch lockwasher. Tighten all hardware securely.

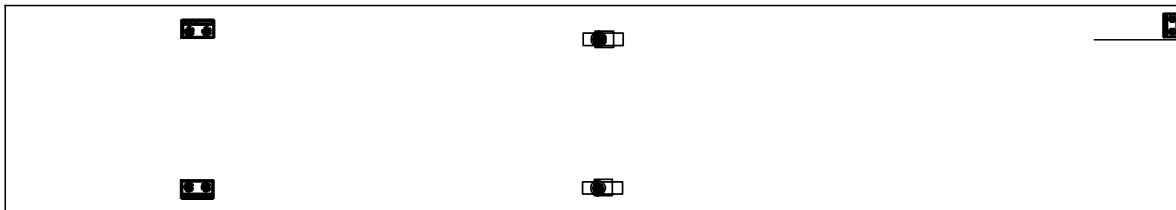

**CARGO BED COVER (CBC), TYPE III, 2 1/2 T CARGO TRUCK, LMTV, AND LMTV TRAILER 0016 00  
UNIT MAINTENANCE**

**Step 9.** With the tailgate in a down position, attach the ladder to the installed first bracket.

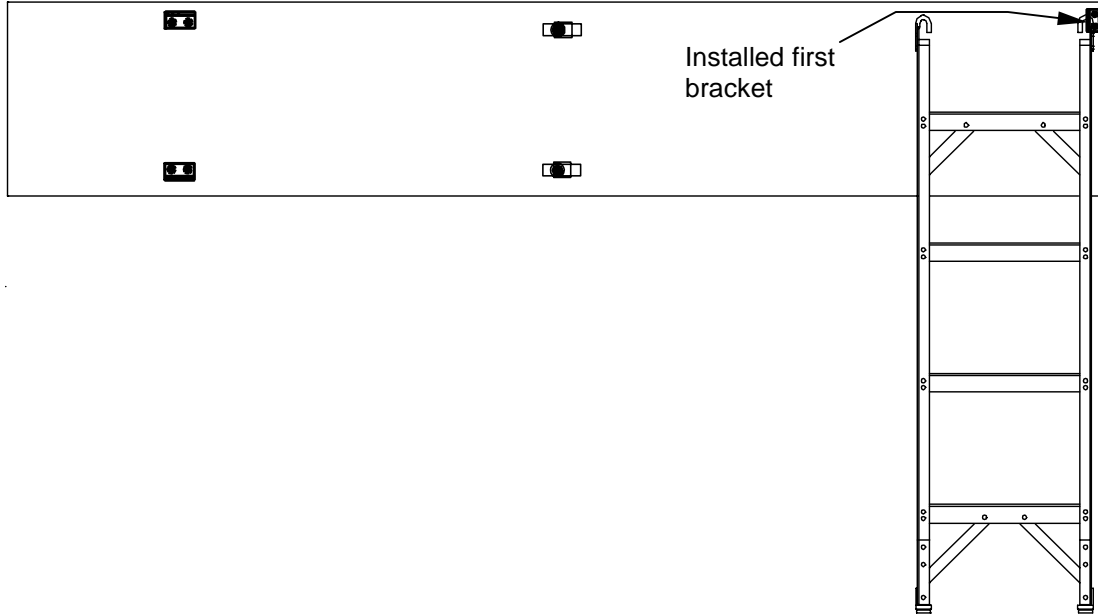

**Step 10.** Using the ladder as a "template", attach the second uninstalled bracket to the opposite side of the ladder (i.e., opposite the installed bracket). Position the second uninstalled bracket so that the mounting holes face away from the first bracket and toward the left edge of the tailgate. Mark the position of the two holes in the second bracket. Remove the ladder from the tailgate.

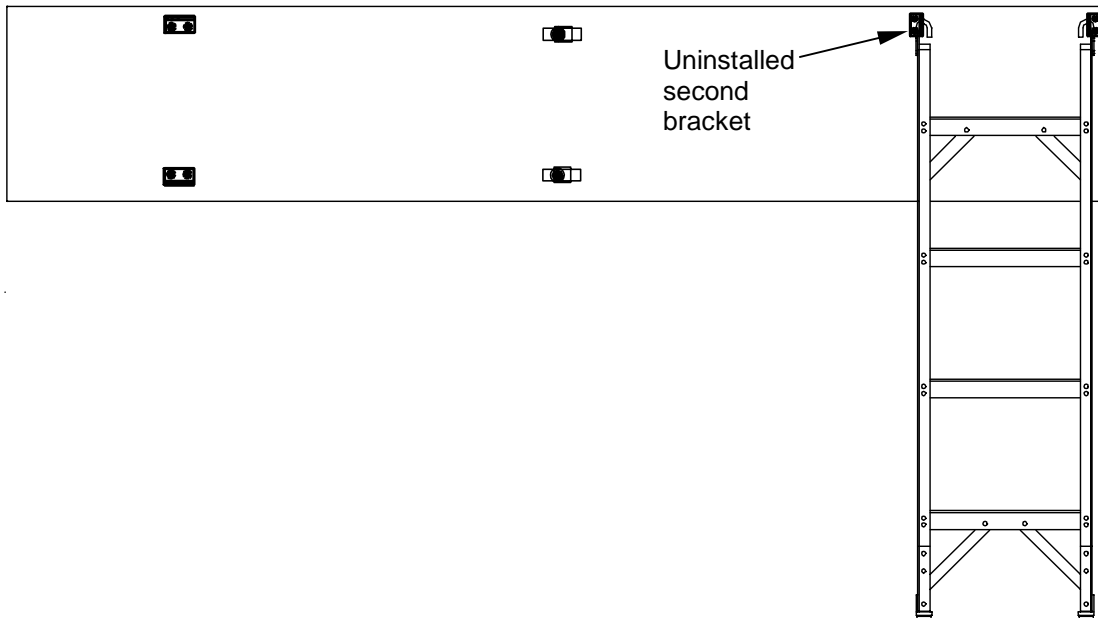

**Step 11.** Repeat prior **Steps 5** through **8** to complete installation of the second bracket.



**CARGO BED COVER (CBC), TYPE III, 2 1/2 T CARGO TRUCK, LMTV, AND LMTV TRAILER 0016 00  
UNIT MAINTENANCE**

**Deploying the ladder.** Lower the hinged tailgate into an approximate vertical position. The ladder (1) mounts to the deployment brackets (2,3) by engaging the hooks (4) in the end of the ladder over the hooked portion (5) of the brackets. The grips (6) at the bottom of the ladder are then allowed to rest on the ground.

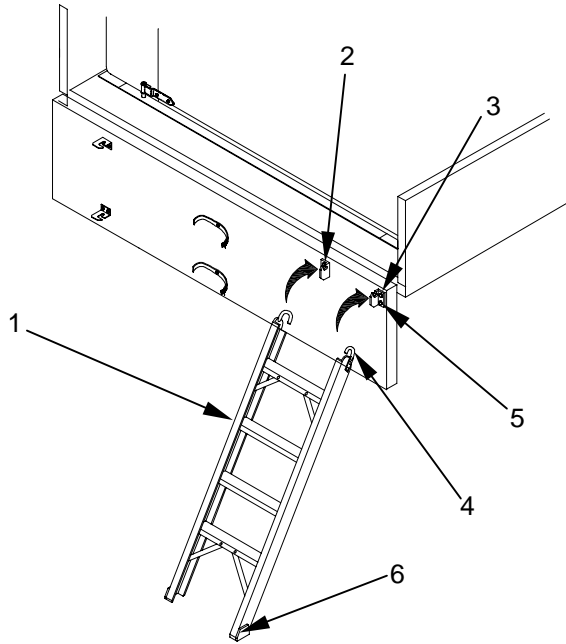

**Stowing the ladder.** To stow the ladder (1), lift and remove it from the deployment brackets (2,3). Place the hooks (4) at the end of the ladder over the stowage brackets (7,8) and secure with strap assemblies (9). Once the ladder is stowed, close the tailgate (10).

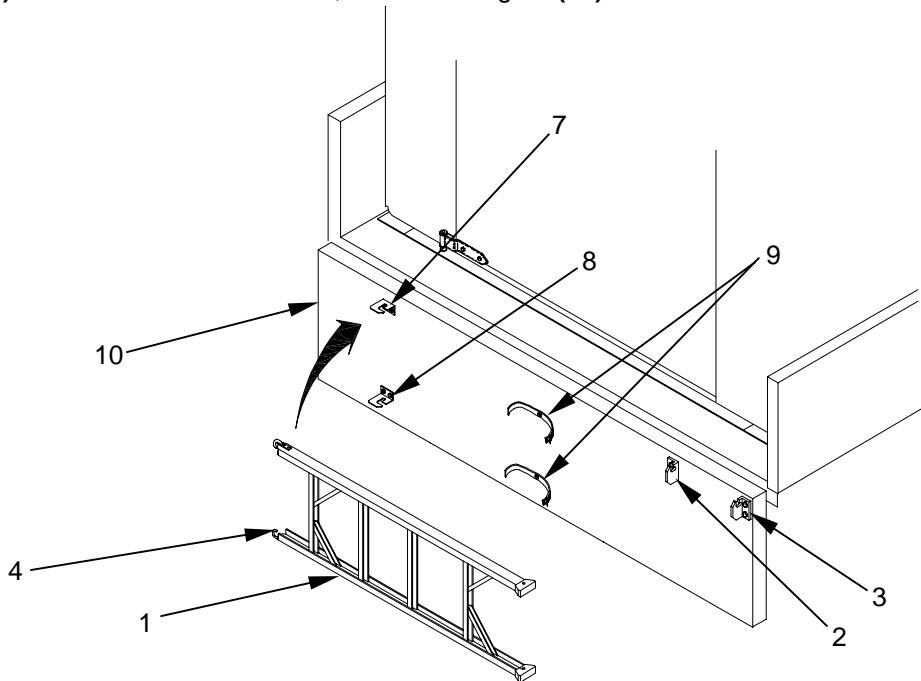

**END OF WORK PACKAGE**



**CARGO BED COVER (CBC), TYPE III, 2 1/2 T CARGO TRUCK, LMTV, AND LMTV TRAILER 0017 00 UNIT MAINTENANCE**

**SIDE WALL REPAIR OF SMALL DENT OR DEPRESSION**

**THIS SECTION COVERS:**

Repair

<b>INITIAL SETUP</b>	<b>Personnel Required:</b> One
<b>Maintenance Level - Unit</b>	<b>Materials/Parts</b>
<b>Tools and Special Tools</b>	Methylethylketone (WP 0055, Table 1, Item 3)
General Mechanic Tool Kit (WP 0041, Table 2, Item 1)	Sandpaper (WP 0055, Table 1, Item 8)
Tripod base heat lamp (WP 0041, Table 2, Item 2)	Wiping Rags (WP 0055, Table 1, Item 6)
Goggles, Industrial (WP 0041, Table 2, Item 3)	Masking tape (WP 0055, Table 1, Item 5)
Gloves, Chemical And Oil Protective (WP 0041, Table 2, Item 6)	Adhesive, Two Part Epoxy (WP 0055, Table 1, Item 9)
	Alodine, Brush (WP 0055, Table 1, Item 12)
	Sticks, Mixing (WP 0055, Table 1, Item 14)



**NOTE**

The following procedure covers repair of a depression or small puncture in any shelter panel skin (depression exceeding 2 square inches (12.9 square cm) or deeper than 0.25 inch (6.4 mm), but not larger than 4 square inches (25.8 square cm) or puncture not larger than 1 square inch (6.5 square cm).



**WARNING**

Safety goggles must be worn during repair to protect eyes from flying metal chips. Failure to wear proper eye protection may result in eye injury and/or blindness.



**WARNING**

Two part epoxy adhesive is flammable and toxic and shall be used only in a well-ventilated area away from all sparks or open flame. Gloves and safety goggles should be worn during use.

**CARGO BED COVER (CBC), TYPE III, 2 1/2 T CARGO TRUCK, LMTV, AND LMTV TRAILER 0017 00  
UNIT MAINTENANCE**



**WARNING**

Methylethylketone is flammable and toxic and shall be used only in a well-ventilated area away from all sparks or open flame. Gloves and safety goggles should be worn during use.

Remove all traces of paint from damaged area **(1)** with sandpaper.

Wipe sanded surface with clean wiping rag dampened in solvent and immediately wipe solvent from surface with a clean, dry wiping rag.

Mask sanded surface with masking tape **(2)**.

Mix a quantity of the adhesive **(3)** in accordance with manufacturers instructions, components (part "A" and part "B") sufficient for the scope of the repair in an open top container. The two adhesive components are different colors; part "A" is yellow and part "B" is blue. When properly and completely mixed, the color of the adhesive is green. Personnel should mix the two parts until the adhesive is a uniform green, with no streaks of yellow or blue.

When performing a repair where injection of the mixed adhesive into the honeycomb core is not required, it is applied directly from the container in which it is mixed.

Using a spatula or putty knife **(4)**, fill damaged area **(1)** with adhesive **(3)**.

Cure adhesive at room temperature (75 degrees F) for 72 hours. Alternate cures can be achieved by exposing the repaired area to 150 degrees F for 3 to 4 hours, or 200 degrees F for 40 to 60 minutes. If 150 degree F or 200 degree F cures are used, allow additional time for repaired area to warm to curing temperature and ensure that the surface temperatures of the CBC do not exceed 225 degrees F.

Sand surface of cured adhesive **(3)** to conform to surrounding area.

Remove masking tape **(2)** and clean repaired surface.

**Apply alodine solution.** Apply the alodine solution with a brush, paint spray gun, cellulose sponge, etc., to the cleaned and rinsed aluminum surface, liberally, quickly and evenly. Allow it to act from 1 to 5 minutes before rinsing.

**NOTE**

The solution should be applied to only as much surface as can be coated and rinsed before the alodine solution dries.

Proceed with the coating and rinsing until the entire surface is coated with alodine.

**Rinse.** Before the alodine solution dries, wipe it from the surface with a clean cloth or sponge wet with clean water. The alodine solution may also be rinsed from the surface with clean water from a hose.

**CARGO BED COVER (CBC), TYPE III, 2 1/2 T CARGO TRUCK, LMTV, AND LMTV TRAILER 0017 00  
UNIT MAINTENANCE**

**Dry.** After the rinsing has been finished, allow the work to air dry. Drying can be speeded by wiping with clean, dry rags. Clean, dry, compressed air should be used to blow moisture from joints, depressions, etc., and to speed the drying. When the surface is entirely dry, the part is ready for service without further treatment, or if desired, it may be painted in accordance with manufacturer's directions.

Refinish in accordance with WP 0039.

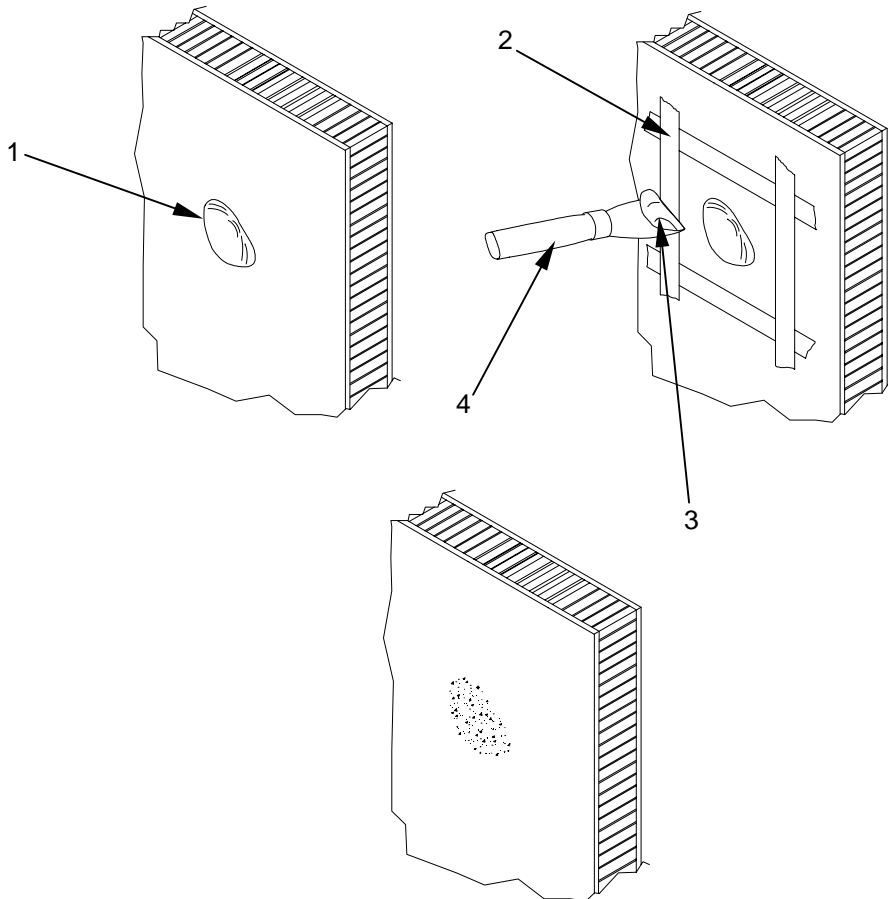

**END OF WORK PACKAGE**



**CARGO BED COVER (CBC), TYPE III, 2 1/2 T CARGO TRUCK, LMTV, AND LMTV TRAILER 0018 00 UNIT MAINTENANCE**

**SIDE WALL REPAIR OF DEPRESSION OR SMALL PUNCTURE**

**THIS SECTION COVERS:**

Repair

<b>INITIAL SETUP</b>	<b>Personnel Required:</b> One
<b>Maintenance Level - Unit</b>	<b>Materials/Parts</b>
<b>Tools and Special Tools</b>	Methylethylketone (WP 0055, Table 1, Item 3)
General Mechanic Tool Kit (WP 0041, Table 2, Item 1)	Sandpaper (WP 0055, Table 1, Item 8)
Light, Incandescent Adjustable With Tripod Base (WP 0041, Table 2, Item 2)	Wiping Rags (WP 0055, Table 1, Item 6)
Goggles, Industrial (WP 0041, Table 2, Item 3)	Masking tape (WP 0055, Table 1, Item 5)
Drill, Electric, Portable (WP 0041, Table 2, Item 4)	Adhesive, Two Part Epoxy (WP 0055, Table 1, Item 9)
Drill Set, Twist (WP 0041, Table 2, Item 5)	Alodine, Brush (WP 0055, Table 1, Item 12)
Gloves, Chemical And Oil Protective (WP 0041, Table 2, Item 6)	Cartridges, 1/10 Gallon Empty (WP 0055, Table 1, Item 10)
Gun, Caulking (WP 0041, Table 2, Item 7)	Nozzle, 2 1/2 In Long With 1/8 In Orifice (WP 0055, Table 1, Item 11)
	Sticks, Mixing (WP 0055, Table 1, Item 14)

**REPAIR**



**NOTE**

The following procedure covers repair of a depression or small puncture in any shelter panel skin (depression exceeding 2 square inches (12.9 square cm) or deeper than 0.25 inch (6.4 mm), but not larger than 4 square inches (25.8 square cm) or puncture not larger than 1 square inch (6.5 square cm).



**WARNING**

Safety goggles must be worn during repair to protect eyes from flying metal chips. Failure to wear proper eye protection may result in eye injury and/or blindness.

**CARGO BED COVER (CBC), TYPE III, 2 1/2 T CARGO TRUCK, LMTV, AND LMTV TRAILER 0018 00  
UNIT MAINTENANCE**



**WARNING**

Two part epoxy adhesive is flammable and toxic and shall be used only in a well-ventilated area away from all sparks or open flame. Gloves and safety goggles should be worn during use.



**WARNING**

Methylethylketone is flammable and toxic and shall be used only in a well-ventilated area away from all sparks or open flame. Gloves and safety goggles should be worn during use.

Drill two 1/8 inch (3.18 mm) diameter holes **(1)** within damaged area.

Mix a quantity of the adhesive **(3)** in accordance with manufacturers instructions, components (part "A" and part "B") sufficient for the scope of the repair in an open top container. The two adhesive components are different colors; part "A" is yellow and part "B" is blue. When properly and completely mixed, the color of the adhesive is green. Personnel should mix the two parts until the adhesive is a uniform green, with no streaks of yellow or blue.

To inject the mixed adhesive into the honeycomb core, adhesive **(3)** must be loaded into an empty 1/10 gallon cartridge. To load the mixed adhesive into the empty cartridge, first install a nozzle onto the end of the empty cartridge, then scoop a quantity of mixed adhesive onto the putty knife and place into the open end of the cartridge. Load a sufficient amount of adhesive into the cartridge for the scope of repair. When the adhesive is completely loaded into the cartridge, install the end cap. Install the cartridge into a standard caulking gun **(2)**.

Inject adhesive through two drilled holes **(1)** to fill core cells completely. Tape over holes in order to hold the adhesive in place during the curing process.

Cure adhesive at room temperature (75 degrees F) for 72 hours. Alternate cures can be achieved by exposing the repaired area to 150 degrees F for 3 to 4 hours, or 200 degrees F for 40 to 60 minutes. If 150 degree F or 200 degree F cures are used, allow additional time for repaired area to warm to curing temperature and ensure that the surface temperatures of the CBC do not exceed 225 degrees F.

Check by tapping damaged area to ensure complete filling of cells.

Sand damaged area with sandpaper to remove all traces of paint and excess adhesive.

**Apply alodine solution.** Apply the alodine solution with a brush, paint spray gun, cellulose sponge, etc., to the cleaned and rinsed aluminum surface, liberally, quickly and evenly. Allow it to act from 1 to 5 minutes before rinsing.



**CARGO BED COVER (CBC), TYPE III, 2 1/2 T CARGO TRUCK, LMTV, AND LMTV TRAILER 0018 00  
UNIT MAINTENANCE**

**NOTE**

The solution should be applied to only as much surface as can be coated and rinsed before the alodine solution dries.

Proceed with the coating and rinsing until the entire surface is coated with alodine.

**Rinse.** Before the alodine solution dries, wipe it from the surface with a clean cloth or sponge wet with clean water. The alodine solution may also be rinsed from the surface with clean water from a hose.

**Dry.** After the rinsing has been finished, allow the work to air dry. Drying can be speeded by wiping with clean, dry rags. Clean, dry, compressed air should be used to blow moisture from joints, depressions, etc., and to speed the drying. When the surface is entirely dry, the part is ready for service without further treatment, or if desired, it may be painted in accordance with manufacturer's directions.

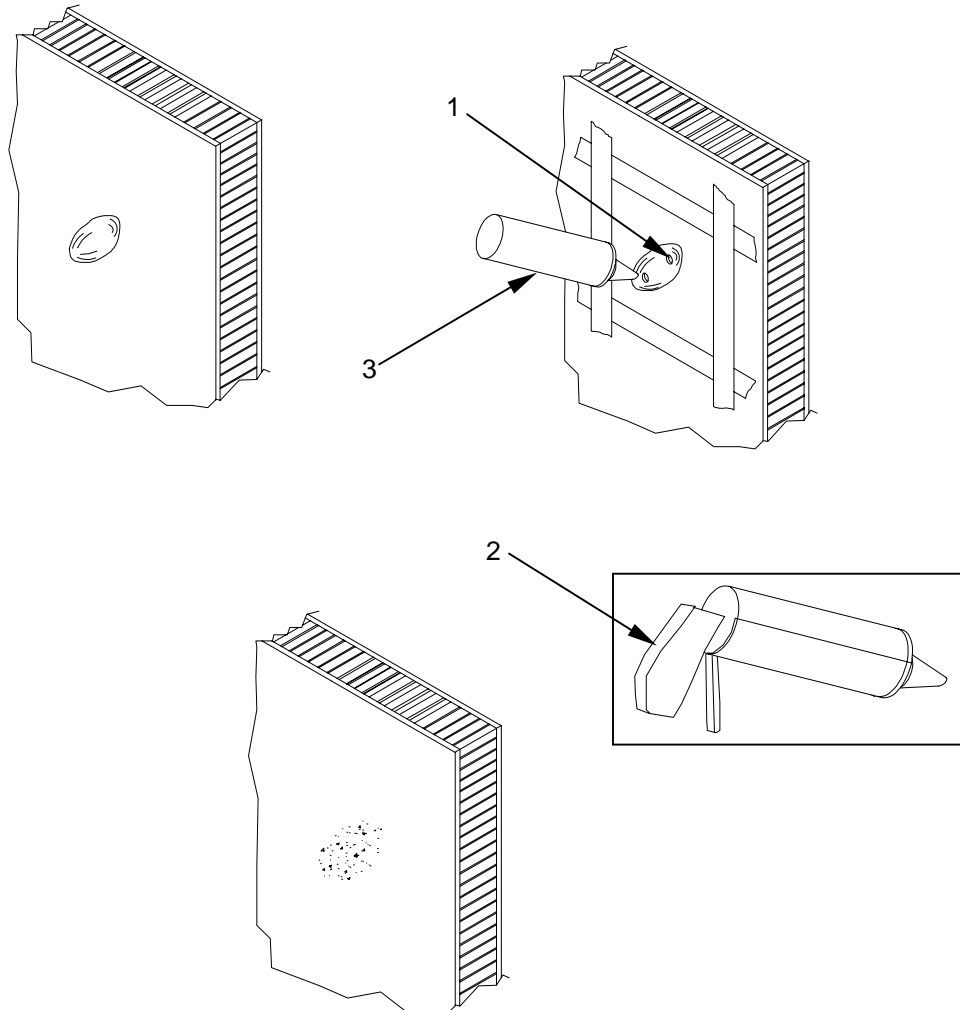

**CARGO BED COVER (CBC), TYPE III, 2 1/2 T CARGO TRUCK, LMTV, AND LMTV TRAILER 0018 00  
UNIT MAINTENANCE**



Methylethylketone is flammable and toxic and shall be used only in a well-ventilated area away from all sparks or open flame. Gloves and safety goggles should be worn during use.

Wipe sanded surface with clean cloth dampened in solvent and immediately wipe solvent from surface with a clean, dry cloth.

Mask sanded surface with masking tape **(1)**.

Mix a small quantity of adhesive **(2)** in accordance with manufacturer's instructions.

Using spatula or putty knife **(3)**, fill damaged area with adhesive.

Cure adhesive at room temperature (75 degrees F) for 72 hours. Alternate cures can be achieved by exposing the repaired area to 150 degrees F for 3 to 4 hours, or 200 degrees F for 40 to 60 minutes. If 150 degree F or 200 degree F cures are used, allow additional time for repaired area to warm to curing temperature and ensure that the surface temperatures of the CBC do not exceed 225 degrees F.

Sand surface of cured adhesive to conform to surrounding area.

Remove masking tape **(1)** and clean repaired surface.

**Apply alodine solution.** Apply the alodine solution with a brush, paint spray gun, cellulose sponge, etc., to the cleaned and rinsed aluminum surface, liberally, quickly and evenly. Allow it to act from 1 to 5 minutes before rinsing.

**NOTE**

The solution should be applied to only as much surface as can be coated and rinsed before the alodine solution dries.

Proceed with the coating and rinsing until the entire surface is coated with alodine.

**Rinse.** Before the alodine solution dries, wipe it from the surface with a clean cloth or sponge wet with clean water. The alodine solution may also be rinsed from the surface with clean water from a hose.

**Dry.** After the rinsing has been finished, allow the work to air dry. Drying can be speeded by wiping with clean, dry rags. Clean, dry, compressed air should be used to blow moisture from joints, depressions, etc., and to speed the drying. When the surface is entirely dry, the part is ready for service without further treatment, or if desired, it may be painted in accordance with manufacturer's directions.

Refinish in accordance with WP 0039.

**CARGO BED COVER (CBC), TYPE III, 2 1/2 T CARGO TRUCK, LMTV, AND LMTV TRAILER 0018 00  
UNIT MAINTENANCE**

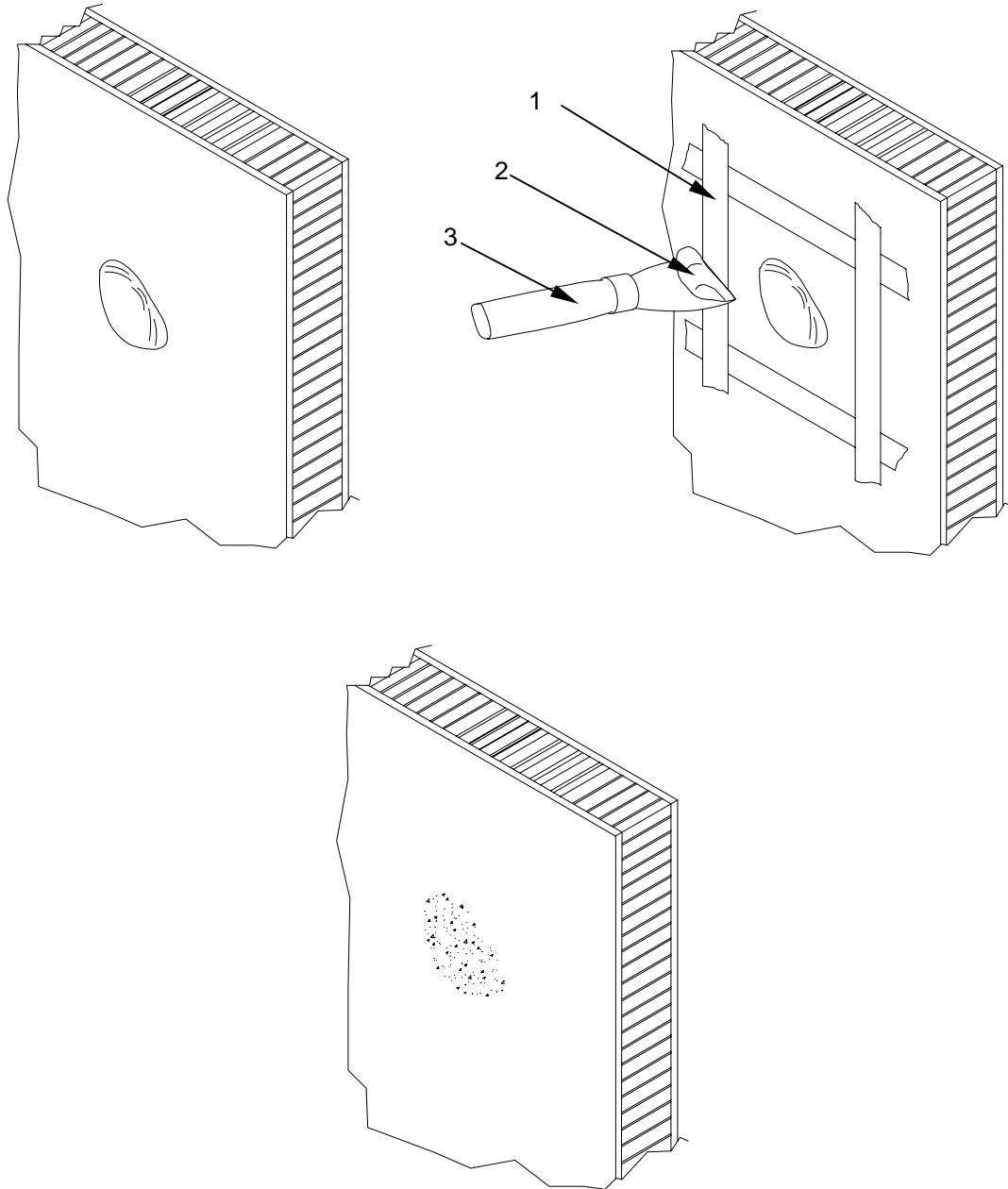

**END OF WORK PACKAGE**



**CARGO BED COVER (CBC), TYPE III, 2 1/2 T CARGO TRUCK, LMTV, AND LMTV TRAILER 0019 00 UNIT MAINTENANCE**

**SIDE WALL REPAIR OF PUNCTURE WITH MINIMAL DAMAGE TO CORE**

**THIS SECTION COVERS:**

Repair

<b>INITIAL SETUP</b>	<b>Personnel Required:</b> One
<b>Maintenance Level - Unit</b>	<b>Materials/Parts</b>
<b>Tools and Special Tools</b>	Methylethylketone (WP 0055, Table 1, Item 3)
General Mechanic Tool Kit (WP 0041, Table 2, Item 1)	Sandpaper (WP 0055, Table 1, Item 8)
Light, Incandescent Adjustable With Tripod Base (WP 0041, Table 2, Item 2)	Wiping Rags (WP 0055, Table 1, Item 6)
Goggles, Industrial (WP 0041, Table 2, Item 3)	Masking tape (WP 0055, Table 1, Item 5)
Drill, Electric, Portable (WP 0041, Table 2, Item 4)	Adhesive, Two Part Epoxy (WP 0055, Table 1, Item 9)
Drill Set, Twist: W/25 Components And Metal Box, Numbered Series (WP 0041, Table 2, Item 8)	Alodine, Brush (WP 0055, Table 1, Item 12)
Drill Set, Twist (WP 0041, Table 2, Item 5)	Cartridges, 1/10 Gallon Empty (WP 0055, Table 1, Item 10)
Gloves, Chemical And Oil Protective (WP 0041, Table 2, Item 6)	Nozzle, 2 1/2 In Long With 1/8 In Orifice (WP 0055, Table 1, Item 11)
Gun, Caulking (WP 0041, Table 2, Item 7)	Sheet, Aluminum, .032 Inch Thick X 12 Inches X 12 Inches (WP 0055, Table 1, Item 15)
Riveter, Hand Blind with 1/8 inch nosepiece (WP 0041, Table 2, Item 9)	Rivet, Blind, 1/8 Inch Dia. (WP 0055, Table 1, Item 13)
Router, Electric, Portable (WP 0041, Table 2, Item 10)	Sticks, Mixing (WP 0055, Table 1, Item 14)

**REPAIR**



**NOTE**

The following procedure covers repair of puncture in any shelter panel skin with minimal core damage (damaged area not exceeding 14 square inches (90.3 square cm)). Use hand router to cut patches and openings.



**WARNING**

Safety goggles must be worn during repair to protect eyes from flying metal chips. Failure to wear proper eye protection may result in eye injury and/or blindness.

**CARGO BED COVER (CBC), TYPE III, 2 1/2 T CARGO TRUCK, LMTV, AND LMTV TRAILER 0019 00  
UNIT MAINTENANCE**

Using a portable electric router equipped with a straight or spiral fluted (pull down) bit, or other aluminum cutting equipment such as aviation metal snips, cut aluminum patch (1) one inch larger than the size of the damaged area.

Lay out and drill holes (2) in patch (1) as shown in accompanying illustration roughly one inch apart.

Center patch (1) over damaged area (3) and mark patch outline on panel skin.

Sand all paint from damaged panel skin within marked area with sandpaper.

Center patch over damaged area (3) and drill No. 30 diameter holes (4) in panel skin. Use holes (2) in patch (1) as a template.

Index patch (1) and panel skin (5) with a mark to allow patch to be replaced in same orientation.

Deburr all drill holes (2,4).



Methylethylketone is flammable and toxic and shall be used only in a well-ventilated area away from all sparks or open flame. Gloves and safety goggles should be worn during use.

Wipe damaged area (3) and patch (1) with a clean cloth dampened in solvent and immediately wipe solvent from surfaces with a clean, dry cloth. Do not allow solvent to get into exposed core.



Two part epoxy adhesive is flammable and toxic and shall be used only in a well-ventilated area away from all sparks or open flame. Gloves and safety goggles should be worn during use.

Mix a quantity of the adhesive in accordance with manufacturers instructions, components (part "A" and part "B") sufficient for the scope of the repair, in an open top container. The two adhesive components are different colors; part "A" is yellow and part "B" is blue. When properly and completely mixed, the color of the adhesive is green. Personnel should mix the two parts until the adhesive is a uniform green, with no streaks of yellow or blue.

Pack adhesive (6) in puncture (7) and all exposed core cells. Use mixing sticks to pack adhesive and obtain a smooth surface.

Apply a thick film of remaining adhesive to mating surface of patch (1).

---

**CARGO BED COVER (CBC), TYPE III, 2 1/2 T CARGO TRUCK, LMTV, AND LMTV TRAILER 0019 00  
UNIT MAINTENANCE**

---

Place patch **(1)** over prepared area in same orientation used in earlier step.

Align holes **(2,4)** and, using hand blind riveter, install 1/8 inch (3.18 mm) diameter blind rivets in accordance with WP 0024.

Cure adhesive at room temperature (75 degrees F) for 72 hours. If a heat source is available, alternate cures can be achieved by exposing the repaired area to 150 degrees F for 3 to 4 hours, or 200 degrees F for 40 to 60 minutes. If 150 degree F or 200 degree F cures are used, allow additional time for repaired area to warm to curing temperature. Ensure that the surface temperature of the CBC does not exceed 225 degrees F.

Clean repaired surface. Caulk around patch in accordance with WP 0025.

**Apply alodine solution.** Apply the alodine solution with a brush, paint spray gun, cellulose sponge, etc., to the cleaned and rinsed aluminum surface, liberally, quickly and evenly. Allow it to act from 1 to 5 minutes before rinsing.



**NOTE**

The solution should be applied to only as much surface as can be coated and rinsed before the alodine solution dries.

Proceed with the coating and rinsing until the entire surface is coated with alodine.

**Rinse.** Before the alodine solution dries, wipe it from the surface with a clean cloth or sponge wet with clean water. The alodine solution may also be rinsed from the surface with clean water from a hose.

**Dry.** After the rinsing has been finished, allow the work to air dry. Drying can be speeded by wiping with clean, dry rags. Clean, dry, compressed air should be used to blow moisture from joints, depressions, etc., and to speed the drying. When the surface is entirely dry, the part is ready for service without further treatment, or if desired, it may be painted in accordance with manufacturer's directions.

Refinish in accordance with WP 0039.

**CARGO BED COVER (CBC), TYPE III, 2 1/2 T CARGO TRUCK, LMTV, AND LMTV TRAILER 0019 00  
UNIT MAINTENANCE**

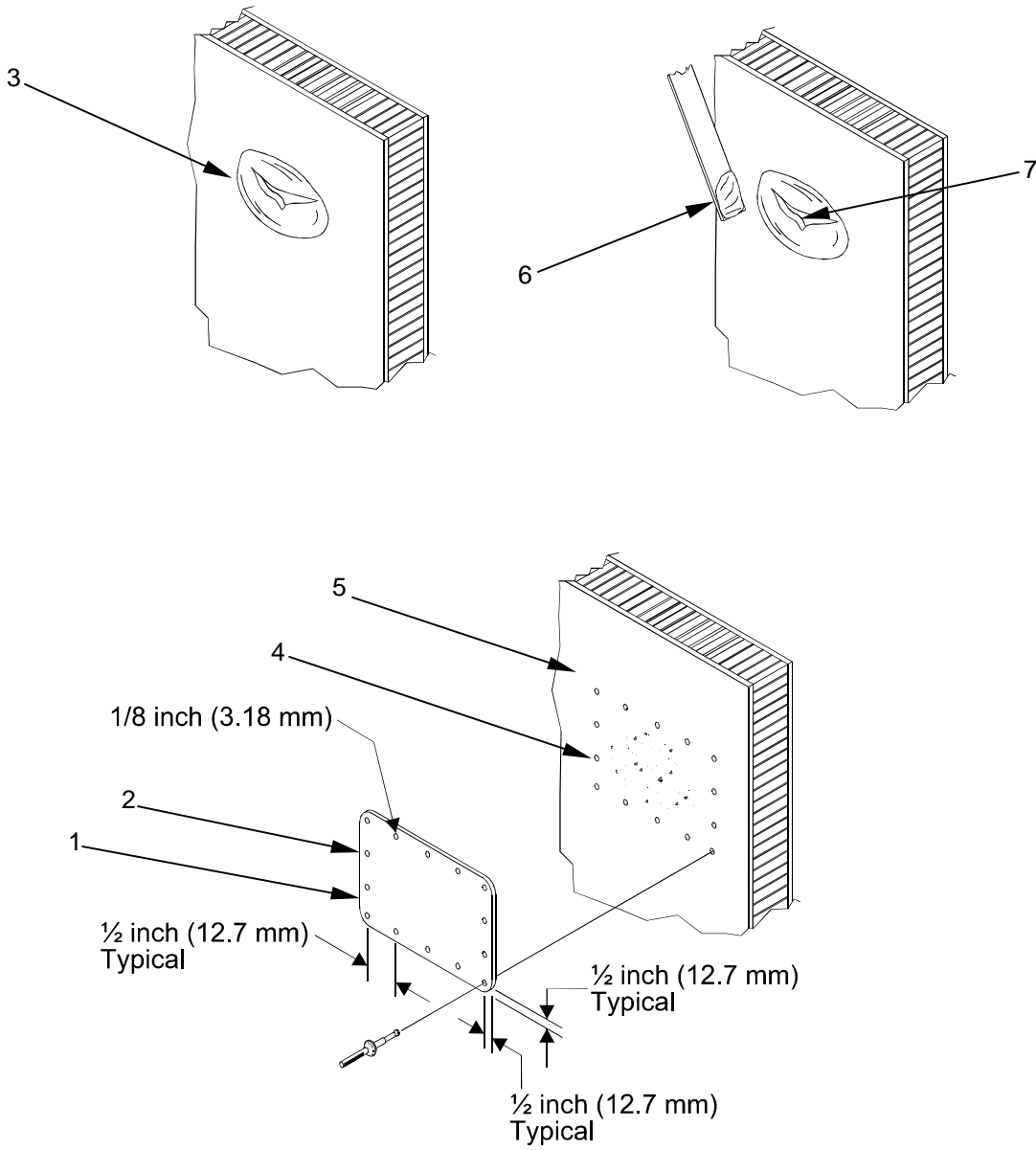

**END OF WORK PACKAGE**



**CARGO BED COVER (CBC), TYPE III, 2 1/2 T CARGO TRUCK, LMTV, AND LMTV TRAILER 0020 00  
UNIT MAINTENANCE**

**SIDE WALL REPAIR OF PUNCTURE WITH CORE FRACTURE**

**THIS SECTION COVERS:**

Repair

<b>INITIAL SETUP</b>	<b>Personnel Required:</b> One
<b>Maintenance Level - Unit</b>	<b>Materials/Parts</b>
<b>Tools and Special Tools</b>	Methylethylketone (WP 0055, Table 1, Item 3) Sandpaper (WP 0055, Table 1, Item 8) Wiping Rags (WP 0055, Table 1, Item 6)
General Mechanic Tool Kit (WP 0041, Table 2, Item 1)	Masking tape (WP 0055, Table 1, Item 5)
Light, Incandescent Adjustable With Tripod Base (WP 0041, Table 2, Item 2)	Alodine, Brush (WP 0055, Table 1, Item 12)
Goggles, Industrial (WP 0041, Table 2, Item 3)	Adhesive, Two Part Epoxy (WP 0055, Table 1, Item 9)
Drill, Electric, Portable (WP 0041, Table 2, Item 4)	Cartridges, 1/10 Gallon Empty (WP 0055, Table 1, Item 10)
Drill Set, Twist: W/25 Components And Metal Box, Numbered Series (WP 0041, Table 2, Item 8)	Nozzle, 2 1/2 In Long With 1/8 In Orifice (WP 0055, Table 1, Item 11)
Drill Set, Twist (WP 0041, Table 2, Item 5)	Sheet, Aluminum, .032 Inch Thick X 12 Inches X 12 Inches (WP 0055, Table 1, Item 15)
Gloves, Chemical And Oil Protective (WP 0041, Table 2, Item 6)	Rivet, Blind, 1/8 Inch Dia. (WP 0055, Table 1, Item 13)
Gun, Caulking (WP 0041, Table 2, Item 7)	Sticks, Mixing (WP 0055, Table 1, Item 14)
Riveter, Hand Blind with 1/8 inch nosepiece (WP 0041, Table 2, Item 9)	
Router, Electric, Portable (WP 0041, Table 2, Item 10)	

**REPAIR**



**NOTE**

The following procedure covers repair of any shelter panel punctured skin with core fracture. (damaged area not to exceed 25 square inches)



**WARNING**

Safety goggles must be worn during repair to protect eyes from flying metal chips. Failure to wear proper eye protection may result in eye injury and/or blindness.

**CARGO BED COVER (CBC), TYPE III, 2 1/2 T CARGO TRUCK, LMTV, AND LMTV TRAILER 0020 00  
UNIT MAINTENANCE**

Cut an opening that is one inch larger than the damaged area, through panel skin with a portable electric router equipped with a straight or spiral fluted (pull down) bit, or other aluminum cutting equipment such as aviation metal snips. Avoid sharp corners in opening.  
Peel damaged portion of skin from core by lifting and rolling skin.

Remove all loose core from exposed core area with compressed air.

Cut aluminum patch **(1)** one-inch larger all around than cutout opening.

Layout and drill holes **(2)** as shown.



Two part epoxy adhesive is flammable and toxic and shall be used only in a well-ventilated area away from all sparks or open flame. Gloves and safety goggles should be worn during use.

Mix a quantity of the adhesive in accordance with manufacturers instructions, components (part "A" and part "B") sufficient for the scope of the repair in an open top container. The two adhesive components are different colors; part "A" is yellow and part "B" is blue. When properly and completely mixed, the color of the adhesive is green. Personnel should mix the two parts until the adhesive is a uniform green, with no streaks of yellow or blue.

Pack adhesive in core cells to fill exposed area above surface of panel skin.

Cure adhesive at room temperature (75 degrees F) for 72 hours. If a heat source is available, alternate cures can be achieved by exposing the repaired area to 150 degrees F for 3 to 4 hours, or 200 degrees F for 40 to 60 minutes. If 150 degree F or 200 degree F cures are used, allow additional time for repaired area to warm to curing temperature. Ensure that the surface temperature of the CBC does not exceed 225 degrees F.

Sand cured adhesive with sandpaper to obtain a smooth contour with surface of panel skin.

Center patch **(1)** over adhesive-filled area and mark patch outline **(3)** on panel skin.

Sand all paint from damaged panel skin within marked area.

Center patch **(1)** over filled area and drill No. 30 diameter holes **(5)** in panel skin. Use holes **(2)** in patch as a template.

Index patch **(1)** and panel skin with a mark to allow patch to be replaced in same orientation.

Deburr all drill holes.

**CARGO BED COVER (CBC), TYPE III, 2 1/2 T CARGO TRUCK, LMTV, AND LMTV TRAILER 0020 00  
UNIT MAINTENANCE**



**WARNING**

Methylethylketone is flammable and toxic and shall be used only in a well-ventilated area away from all sparks or open flame. Gloves and safety goggles should be worn during use.

Wipe damaged area and patch with a clean cloth dampened in solvent and immediately wipe solvent from surfaces with a clean, dry cloth.

Spray the repair area with an Alodine solution. Wipe the surface with a clean, dry rag.



**WARNING**

Two part epoxy adhesive is flammable and toxic and shall be used only in a well-ventilated area away from all sparks or open flame. Gloves and safety goggles should be worn during use.

Mix sufficient amount of adhesive in accordance with above instructions to coat one side of patch **(1)**.

Apply a thick film of adhesive to mating surface of patch.

Place patch over prepared area in same orientation used in earlier step.

Align holes **(2,5)** and, using hand blind riveter, install 1/8 inch (3.18 mm) diameter blind rivets **(4)**, in accordance with WP 0024.

Clean repaired surface.

Caulk around repair patch **(1)** in accordance with WP 0025.

**Apply alodine solution.** Apply the alodine solution with a brush, paint spray gun, cellulose sponge, etc., to the cleaned and rinsed aluminum surface, liberally, quickly and evenly. Allow it to act from 1 to 5 minutes before rinsing.



**NOTE**

The solution should be applied to only as much surface as can be coated and rinsed before the alodine solution dries.

**CARGO BED COVER (CBC), TYPE III, 2 1/2 T CARGO TRUCK, LMTV, AND LMTV TRAILER 0020 00  
UNIT MAINTENANCE**

Proceed with the coating and rinsing until the entire surface is coated with alodine.

**Rinse.** Before the alodine solution dries, wipe it from the surface with a clean cloth or sponge wet with clean water. The alodine solution may also be rinsed from the surface with clean water from a hose.

**Dry.** After the rinsing has been finished, allow the work to air dry. Drying can be speeded by wiping with clean, dry rags. Clean, dry, compressed air should be used to blow moisture from joints, depressions, etc., and to speed the drying. When the surface is entirely dry, the part is ready for service without further treatment, or if desired, it may be painted in accordance with manufacturer's directions.

Refinish in accordance with WP 0039.

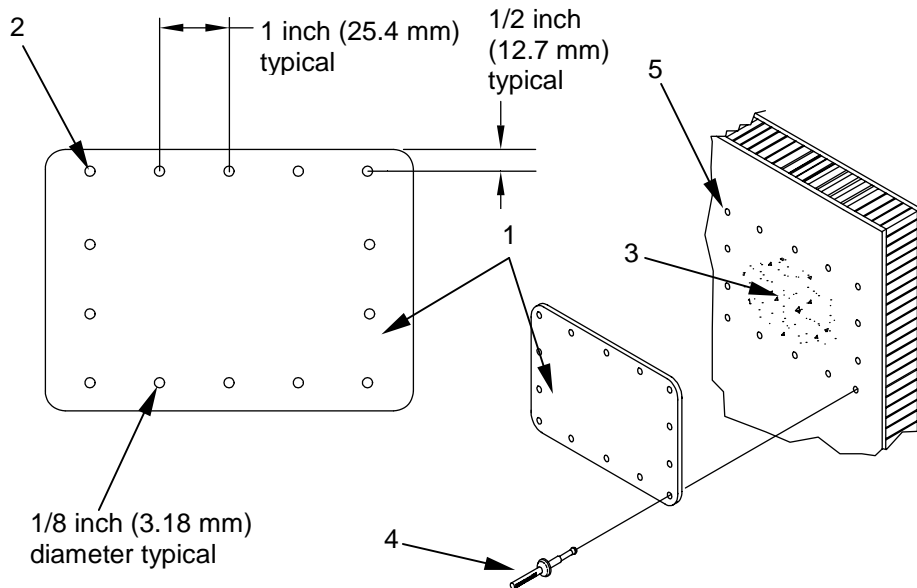
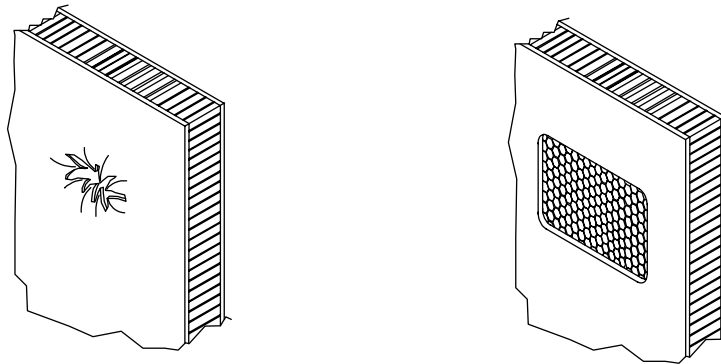

**END OF WORK PACKAGE**

**CARGO BED COVER (CBC), TYPE III, 2 1/2 T CARGO TRUCK, LMTV, AND LMTV TRAILER 0021 00 UNIT MAINTENANCE**

**SIDE WALL REPAIR OF DAMAGE WITH EXTENDED CRACKS**

**THIS SECTION COVERS:**

Repair

<b>INITIAL SETUP</b>	<b>Personnel Required:</b> One
<b>Maintenance Level - Unit</b>	<b>Materials/Parts</b>
<b>Tools and Special Tools</b>	Methylethylketone (WP 0055, Table 1, Item 3)
General Mechanic Tool Kit (WP 0041, Table 2, Item 1)	Sandpaper (WP 0055, Table 1, Item 8)
Light, Incandescent Adjustable With Tripod Base (WP 0041, Table 2, Item 2)	Wiping Rags (WP 0055, Table 1, Item 6)
Goggles, Industrial (WP 0041, Table 2, Item 3)	Masking tape (WP 0055, Table 1, Item 5)
Drill, Electric, Portable (WP 0041, Table 2, Item 4)	Alodine, Brush (WP 0055, Table 1, Item 12)
Drill Set, Twist: W/25 Components And Metal Box, Numbered Series (WP 0041, Table 2, Item 8)	Adhesive, Two Part Epoxy (WP 0055, Table 1, Item 9)
Drill Set, Twist (WP 0041, Table 2, Item 5)	Cartridges, 1/10 Gallon Empty (WP 0055, Table 1, Item 10)
Gloves, Chemical And Oil Protective (WP 0041, Table 2, Item 6)	Nozzle, 2 1/2 In Long With 1/8 In Orifice (WP 0055, Table 1, Item 11)
Gun, Caulking (WP 0041, Table 2, Item 7)	Sheet, Aluminum, .032 Inch Thick X 12 Inches X 12 Inches (WP 0055, Table 1, Item 15)
Riveter, Hand Blind with 1/8 inch nosepiece (WP 0041, Table 2, Item 9)	Rivet, Blind, 1/8 Inch Dia. (WP 0055, Table 1, Item 13)
Router, Electric, Portable (WP 0041, Table 2, Item 10)	Sticks, Mixing (WP 0055, Table 1, Item 14)

**REPAIR**



**NOTE**

The following procedure covers repair of extended cracks (such as a long cut) in panel skin, (damaged area does not exceed 36 inches [91.44 cm] square).



**WARNING**

Safety goggles must be worn during repair to protect eyes from flying metal chips. Failure to wear proper eye protection may result in eye injury and/or blindness.

**CARGO BED COVER (CBC), TYPE III, 2 1/2 T CARGO TRUCK, LMTV, AND LMTV TRAILER 0021 00  
UNIT MAINTENANCE**

Using portable electric router equipped with a straight or spiral fluted (pull down) bit, or other aluminum cutting equipment such as aviation metal snips, cut aluminum patch **(1)** one inch larger all around the damaged area.

Layout and drill 1/8 inch (3.18 mm) holes **(2)** as shown.

Stop-drill all cracks **(3)** with No. 30 (3.27 mm) drill bit. Stop-drilling is the practice of drilling a hole at each end of a crack to prevent it from getting larger.

Center patch **(1)** over damaged area and mark patch outline **(4)** on panel skin.

Sand all paint from damaged skin within marked area with sandpaper.

Center patch **(1)** over damaged area and drill No. 30 diameter holes **(5)** in panel skin. Use holes **(2)** in patch **(1)** as a template.

Index patch **(1)** and panel skin with a mark to allow patch to be replaced in same orientation.

Deburr all drill holes **(2,5)**.



**WARNING**

Methylethylketone is flammable and toxic and shall be used only in a well-ventilated area away from all sparks or open flame. Gloves and safety goggles should be worn during use.

Wipe damaged area and patch **(1)** with a clean cloth dampened in solvent and immediately wipe solvent from surfaces with a clean, dry cloth.

Spray the repair area with an Alodine solution. Wipe the surface with a clean, dry rag.



**WARNING**

Two part epoxy adhesive is flammable and toxic and shall be used only in a well-ventilated area away from all sparks or open flame. Gloves and safety goggles should be worn during use.

Mix a quantity of the adhesive in accordance with manufacturer's instructions, components (part "A" and part "B") sufficient for the scope of the repair in an open top container. The two adhesive components are different colors; part "A" is yellow and part "B" is blue. When properly and completely mixed, the color of the adhesive is green. Personnel should mix the two parts until the adhesive is a uniform green, with no streaks of yellow or blue.

**CARGO BED COVER (CBC), TYPE III, 2 1/2 T CARGO TRUCK, LMTV, AND LMTV TRAILER 0021 00  
UNIT MAINTENANCE**

---

Pack adhesive in core cells to fill exposed area above surface of panel skin.

Cure adhesive at room temperature (75 degrees F) for 72 hours. If a heat source is available, alternate cures can be achieved by exposing the repaired area to 150 degrees F for 3 to 4 hours, or 200 degrees F for 40 to 60 minutes. If 150 degree F or 200 degree F cures are used, allow additional time for repaired area to warm to curing temperature. Ensure that the surface temperature of the CBC does not exceed 225 degrees F.

Sand cured adhesive with sandpaper to obtain a smooth contour with surface of panel skin.

Wipe sanded area and patch **(1)** with a clean cloth dampened in solvent and immediately wipe solvent from surfaces with a clean, dry cloth.

Mix an amount of adhesive in accordance with manufacturer's instructions, sufficient to coat one side of patch.

Apply a thick film of adhesive to mating surface of patch **(1)**.

Place patch over prepared area in same orientation used in earlier step.

Align holes **(2)** and using hand blind riveter, install 1/8 inch (3.18 mm) diameter blind rivet **(6)**.

Clean repaired surface.

Caulk around repair patch **(1)**. (Refer to WP 0025).

**Apply alodine solution.** Apply the alodine solution with a brush, paint spray gun, cellulose sponge, etc., to the cleaned and rinsed aluminum surface, liberally, quickly and evenly. Allow it to act from 1 to 5 minutes before rinsing.



**NOTE**

The solution should be applied to only as much surface as can be coated and rinsed before the alodine solution dries.

Proceed with the coating and rinsing until the entire surface is coated with alodine.

**Rinse.** Before the alodine solution dries, wipe it from the surface with a clean cloth or sponge wet with clean water. The alodine solution may also be rinsed from the surface with clean water from a hose.

**Dry.** After the rinsing has been finished, allow the work to air dry. Drying can be speeded by wiping with clean, dry rags. Clean, dry, compressed air should be used to blow moisture from joints, depressions, etc., and to speed the drying. When the surface is entirely dry, the part is ready for service without further treatment, or if desired, it may be painted in accordance with manufacturer's directions.

Refinish in accordance with WP 0039.

**CARGO BED COVER (CBC), TYPE III, 2 1/2 T CARGO TRUCK, LMTV, AND LMTV TRAILER 0021 00  
UNIT MAINTENANCE**

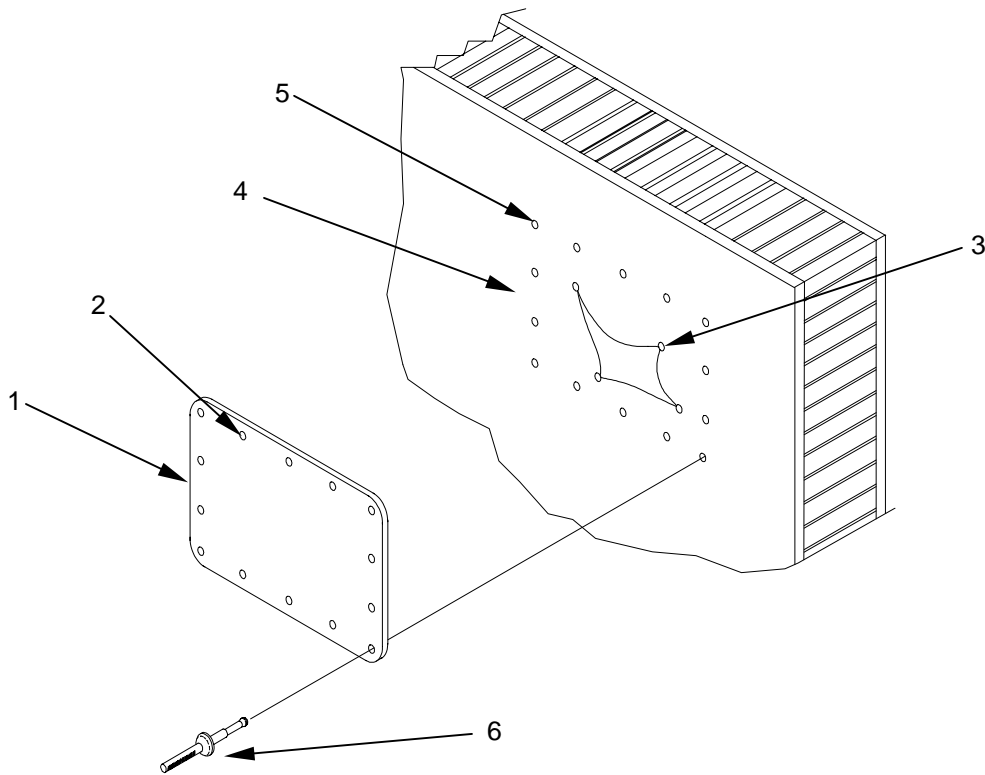
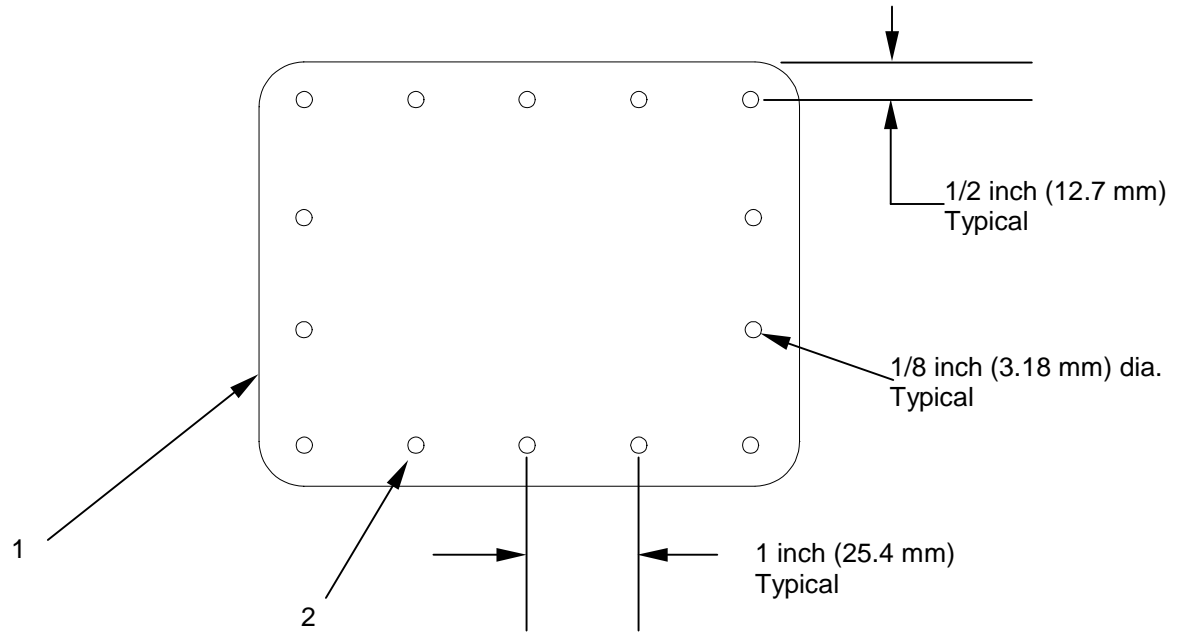

**END OF WORK PACKAGE**



**CARGO BED COVER (CBC), TYPE III, 2 1/2 T CARGO TRUCK, LMTV, AND LMTV TRAILER 0022 00 UNIT MAINTENANCE**

**SIDE WALL REPAIR OF PUNCTURE THROUGH ONE SKIN AND CORE**

**THIS SECTION COVERS:**

Repair

<b>INITIAL SETUP:</b>	<b>Personnel Required:</b> One
<b>Maintenance Level - Unit</b>	<b>Materials/Parts</b>
<b>Tools and Special Tools</b>	Methylethylketone (WP 0055, Table 1, Item 3) Sandpaper (WP 0055, Table 1, Item 8) Wiping Rags (WP 0055, Table 1, Item 6)
General Mechanic Tool Kit (WP 0041, Table 2, Item 1)	Masking tape (WP 0055, Table 1, Item 5)
Light, Incandescent Adjustable With Tripod Base (WP 0041, Table 2, Item 2)	Alodine, Brush (WP 0055, Table 1, Item 12) Adhesive, Two Part Epoxy (WP 0055, Table 1, Item 9)
Goggles, Industrial (WP 0041, Table 2, Item 3)	Cartridges, 1/10 Gallon Empty (WP 0055, Table 1, Item 10)
Drill, Electric, Portable (WP 0041, Table 2, Item 4)	Nozzle, 2 1/2 In Long With 1/8 In Orifice (WP 0055, Table 1, Item 11)
Drill Set, Twist: W/25 Components And Metal Box, Numbered Series (WP 0041, Table 2, Item 8)	Sheet, Aluminum, .032 Inch Thick X 12 Inches X 12 Inches (WP 0055, Table 1, Item 15)
Drill Set, Twist (WP 0041, Table 2, Item 5)	Rivet, Dome, HD, 1/8 Inch Dia. (WP 0055, Table 1, Item 13)
Gloves, Chemical And Oil Protective (WP 0041, Table 2, Item 6)	Sticks, Mixing (WP 0055, Table 1, Item 14)
Gun, Caulking (WP 0041, Table 2, Item 7)	Core, 1.00 (OR 1.50) Inch Thick X 12 Inches X 12 Inches (WP 0055, Table 1, Item 16 OR 17)*
Riveter, Hand Blind with 1/8 inch nosepiece (WP 0041, Table 2, Item 9)	
Router, Electric, Portable (WP 0041, Table 2, Item 10)	

*\* core material thickness depends on thickness of side wall being repaired*

**REPAIR**



**NOTE**

The following procedure covers repair of panel puncture through one skin with core damage (damaged area does not exceed 100 square inches [645 square cm]).



**NOTE**

Openings may be oval, circular, square or rectangular with rounded corners.

---

**CARGO BED COVER (CBC), TYPE III, 2 1/2 T CARGO TRUCK, LMTV, AND LMTV TRAILER 0022 00  
UNIT MAINTENANCE**

---



**WARNING**

Safety goggles must be worn during repair to protect eyes from flying metal chips. Failure to wear proper eye protection may result in eye injury and/or blindness.

Cut an opening through panel skin with portable electric router equipped with a straight or spiral fluted (pull down) bit, or other aluminum cutting equipment such as aviation metal snips, that is one inch greater than the damaged area. Avoid sharp corners in opening.

Peel damaged portion of skin from core by lifting and rolling skin with screwdriver and pliers.

Trim core area with a utility knife to same size as opening while leaving small amount of core material on opposite skin.

Cut a rectangular-shaped aluminum patch **(1)** 1-1/2 inch (3.8 cm), larger all around than cutout opening.

Lay out and drill 1/8 inch (3.18 mm) diameter holes **(2)** in patch.

Cut a section of core material the same size as cutout opening. Core plug should be flush with or slightly lower than panel skin surface.

Center patch over cutout opening and mark patch outline **(3)** on panel skin. Drill No. 30 diameter holes in panel skin with patch as template.

**CAUTION**

Do not use power sander when removing paint.

Sand all paint from panel skin within marked area with sandpaper.



**WARNING**

Use facemask when sanding.

Index patch and panel skin with a mark to allow patch to be replaced with same orientation.

Deburr drill holes **(2)** and sand all paint from panel skin within marked area. Clean loose core material, dust, and chips from cutout opening.

**CARGO BED COVER (CBC), TYPE III, 2 1/2 T CARGO TRUCK, LMTV, AND LMTV TRAILER 0022 00  
UNIT MAINTENANCE**



Methylethylketone is flammable and toxic and shall be used only in a well-ventilated area away from sparks or open flame. Gloves and safety goggles should be worn during use.

Wipe panel skin within marked area and patch (1) with a clean cloth dampened with solvent and immediately wipe solvent from surfaces with a clean, dry cloth.



Two part epoxy adhesive is flammable and toxic and shall be used only in a well-ventilated area away from all sparks or open flame. Gloves and safety goggles should be worn during use.

Mix a quantity of the adhesive in accordance with manufacturer's instructions, components (part "A" and part "B") sufficient for the scope of the repair in an open top container. The two adhesive components are different colors; part "A" is yellow and part "B" is blue. When properly and completely mixed, the color of the adhesive is green. Personnel should mix the two parts until the adhesive is a uniform green, with no streaks of yellow or blue.

Apply an even coat of adhesive to cutout core surfaces.

Insert core plug in cutout opening and press firmly in place.

Apply an even coat of adhesive around core plug and fill any gaps around plug.

Cure adhesive at room temperature (75 degrees F) for 72 hours. If a heat source is available, alternate cures can be achieved by exposing the repaired area to 150 degrees F for 3 to 4 hours, or 200 degrees F for 40 to 60 minutes. If 150 degree F or 200 degree F cures are used, allow additional time for repaired area to warm to curing temperature. Ensure that the surface temperature of the CBC does not exceed 225 degrees F.

Sand cured adhesive with sandpaper to obtain a smooth contour with surface of panel skin.

Apply an even coat of adhesive to mating surface of patch.

Place patch (1) over prepared area in same orientation as marked in earlier step. Align holes and using hand blind riveter, install 1/8-inch (3.18 mm) diameter blind rivet in accordance with WP 0024.

---

**CARGO BED COVER (CBC), TYPE III, 2 1/2 T CARGO TRUCK, LMTV, AND LMTV TRAILER 0022 00  
UNIT MAINTENANCE**

---

Clean repaired surface.

Caulk around repair patch **(1)** in accordance with WP 0025.

**Apply alodine solution.** Apply the alodine solution with a brush, paint spray gun, cellulose sponge, etc., to the cleaned and rinsed aluminum surface, liberally, quickly and evenly. Allow it to act from 1 to 5 minutes before rinsing.



**NOTE**

The solution should be applied to only as much surface as can be coated and rinsed before the alodine solution dries.

Proceed with the coating and rinsing until the entire surface is coated with alodine.

**Rinse.** Before the alodine solution dries, wipe it from the surface with a clean cloth or sponge wet with clean water. The alodine solution may also be rinsed from the surface with clean water from a hose.

**Dry.** After the rinsing has been finished, allow the work to air dry. Drying can be speeded by wiping with clean, dry rags. Clean, dry, compressed air should be used to blow moisture from joints, depressions, etc., and to speed the drying. When the surface is entirely dry, the part is ready for service without further treatment, or if desired, it may be painted in accordance with manufacturer's directions.

Refinish in accordance with WP 0039.

**CARGO BED COVER (CBC), TYPE III, 2 1/2 T CARGO TRUCK, LMTV, AND LMTV TRAILER 0022 00  
UNIT MAINTENANCE**

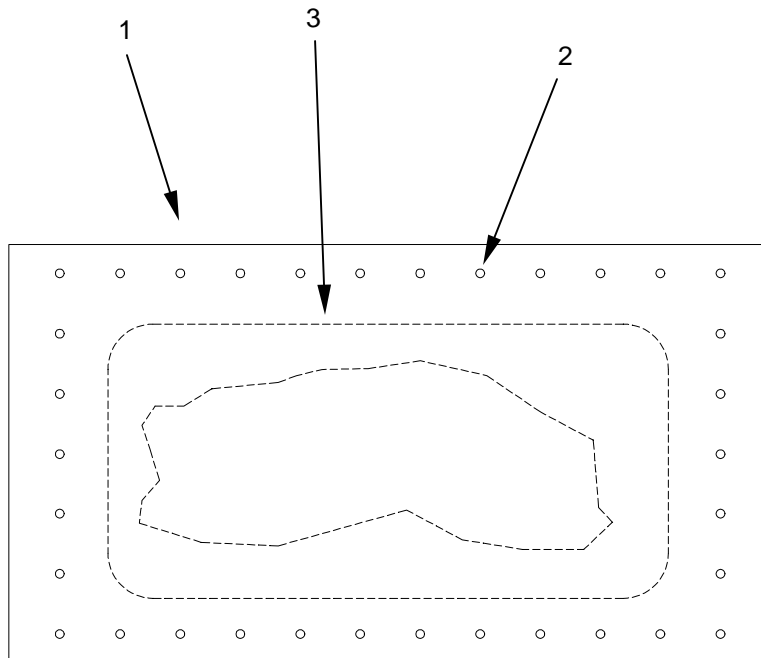
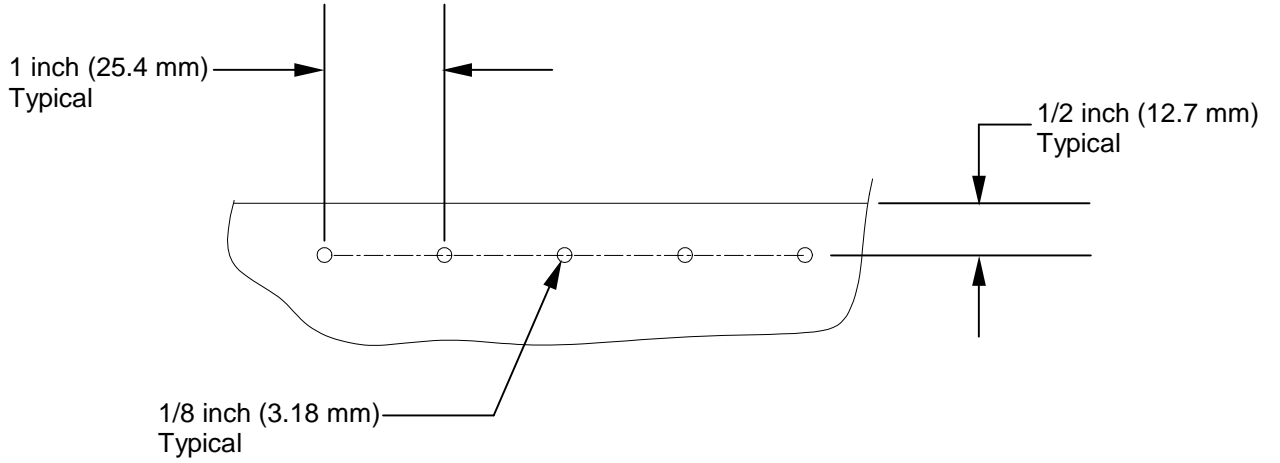

**END OF WORK PACKAGE**



**CARGO BED COVER (CBC), TYPE III, 2 1/2 T CARGO TRUCK, LMTV, AND LMTV TRAILER 0023 00 UNIT MAINTENANCE**

**SIDE WALL REPAIR OF PUNCTURE THROUGH BOTH SKINS AND CORE**

**THIS SECTION COVERS:**

Repair

<b>INITIAL SETUP:</b>	<b>Personnel Required:</b> One
<b>Maintenance Level - Unit</b>	<b>Materials/Parts</b>
<b>Tools and Special Tools</b>	Methylethylketone (WP 0055, Table 1, Item 3)
General Mechanic Tool Kit (WP 0041, Table 2, Item 1)	Sandpaper (WP 0055, Table 1, Item 8)
Light, Incandescent Adjustable With Tripod Base (WP 0041, Table 2, Item 2)	Wiping Rags (WP 0055, Table 1, Item 6)
Goggles, Industrial (WP 0041, Table 2, Item 3)	Masking tape (WP 0055, Table 1, Item 5)
Drill, Electric, Portable (WP 0041, Table 2, Item 4)	Alodine, Brush (WP 0055, Table 1, Item 12)
Drill Set, Twist: W/25 Components And Metal Box, Numbered Series (WP 0041, Table 2, Item 8)	Adhesive, Two Part Epoxy (WP 0055, Table 1, Item 9)
Drill Set, Twist (WP 0041, Table 2, Item 5)	Cartridges, 1/10 Gallon, Empty (WP 0055, Table 1, Item 10)
Gloves, Chemical And Oil Protective (WP 0041, Table 2, Item 6)	Nozzle, 2 1/2 In Long With 1/8 In Orifice (WP 0055, Table 1, Item 11)
Gun, Caulking (WP 0041, Table 2, Item 7)	Sheet, Aluminum, .032 Inch Thick X 12 Inches X 12 Inches (WP 0055, Table 1, Item 15)
Riveter, Hand Blind with 1/8 inch nosepiece (WP 0041, Table 2, Item 9)	Rivet, Dome, HD, 1/8 Inch Dia. (WP 0055, Table 1, Item 13)
Router, Electric, Portable (WP 0041, Table 2, Item 10)	Sticks, Mixing (WP 0055, Table 1, Item 14)
	Core, 1.00 (OR 1.50) Inch Thick X 12 Inches X 12 Inches (WP 0055, Table 1, Item 16 OR 17)*

\* core material thickness depends on thickness of side wall being repaired

**REPAIR**



**NOTE**

The following procedures cover repair of panel puncture through both skins and core (damage area does not exceed 100 square inches (645 square cm). Use hand router to cut patches and openings.

Cut an opening through panel skin with portable electric router equipped with a straight or spiral fluted (pull down) bit, or other aluminum cutting equipment such as aviation metal snips, that is one inch greater than damaged area. Avoid sharp corners in opening.

**CARGO BED COVER (CBC), TYPE III, 2 1/2 T CARGO TRUCK, LMTV, AND LMTV TRAILER 0023 00  
UNIT MAINTENANCE**



**NOTE**

Openings may be oval, circular, square or rectangular with rounded corners. Ensure core ribbon direction is same as panel.

Cut a core plug **(2)** and two aluminum patches **(1)** one to three inches larger all around than cutout opening.



**WARNING**

Two part epoxy adhesive is flammable and toxic and shall be used only in a well-ventilated area away from all sparks or open flame. Gloves and safety goggles should be worn during use.

Mix a quantity of the adhesive in accordance with manufacturer's instructions, components (part "A" and part "B") in an open top container sufficient to bond two patches **(2)** to core plug **(1)**. The two adhesive components are different colors; part "A" is yellow and part "B" is blue. When properly and completely mixed, the color of the adhesive is green. Personnel should mix the two parts until the adhesive is a uniform green, with no streaks of yellow or blue.



**WARNING**

Methylethylketone is flammable and toxic and shall be used only in a well-ventilated area away from sparks or open flame. Gloves and safety goggles should be worn during use.

Wipe patches **(2)** with a clean cloth dampened with solvent and immediately wipe solvent from surfaces with a clean, dry cloth.

Apply a thick coat of adhesive to one side of each patch.

Place core plug **(2)** between two patches **(1)** to create a sandwich panel **(3)**.

Cure adhesive at room temperature (75 degrees F) for 72 hours. If a heat source is available, alternate cures can be achieved by exposing the repaired area to 150 degrees F for 3 to 4 hours, or 200 degrees F for 40 to 60 minutes. If 150 degree F or 200 degree F cures are used, allow additional time for repaired area to warm to curing temperature. Ensure that the surface temperature of the CBC does not exceed 225 degrees F.



---

**CARGO BED COVER (CBC), TYPE III, 2 1/2 T CARGO TRUCK, LMTV, AND LMTV TRAILER 0023 00  
UNIT MAINTENANCE**

---

Cut bonded sandwich panel **(3)** to same size as cutout opening as detailed in earlier step. Ensure core ribbon direction is same as panel.

Cut two aluminum patches **(7)** 1-1/2 inch (3.8 cm) larger all around than cutout opening.

Layout and drill 1/8 inch (3.18 mm) diameter holes **(4)** in patches.

Position bonded sandwich panel **(3)** in cutout opening.

Center patches **(7)**, one on each side of panel, over cutout opening.

Drill No. 30 (3.27 mm) diameter holes **(8)** in panel skins and bonded sandwich panel with patches as templates.

Mark each patch outline **(5)** on panel skin and sand all paint from panel skin within marked area with sandpaper.

Index each patch and panel skin with a mark to allow patches to be replaced with same orientation.

Remove patches **(7)** and bonded sandwich panel **(3)**.

Deburr drill holes **(4,8)** and sand all paint from panel skin within marked areas.

Clean loose core material, dust, and chips from cutout opening.

Wipe panel skin within marked areas (two patches) and bonded sandwich panel metal skin with a clean cloth dampened with solvent. Immediately wipe solvent from surfaces with a clean, dry cloth.

Mix a sufficient amount of adhesive in accordance with manufacturer's instructions, as detailed above.

Apply a thick coat of adhesive to inside surfaces of panel cutout opening, bonded sandwich panel and two patches.

Position bonded sandwich panel in cutout opening.

Fill any gaps between cutout opening and bonded sandwich panel with adhesive.

Place patches **(7)** over prepared areas in same orientation as described in earlier step.

Align holes **(4,8)** and using hand blind riveter, install 1/8 inch (3.18 mm) diameter blind rivet **(6)**, in accordance with WP 0024.

Clean repaired surfaces.

Caulk around repair patches **(7)** in accordance with WP 0025.

**Apply alodine solution.** Apply the alodine solution with a brush, paint spray gun, cellulose sponge, etc., to the cleaned and rinsed aluminum surface, liberally, quickly and evenly. Allow it to act from 1 to 5 minutes before rinsing.

---

**CARGO BED COVER (CBC), TYPE III, 2 1/2 T CARGO TRUCK, LMTV, AND LMTV TRAILER 0023 00  
UNIT MAINTENANCE**

---



**NOTE**

The solution should be applied to only as much surface as can be coated and rinsed before the alodine solution dries.

Proceed with the coating and rinsing until the entire surface is coated with alodine.

**Rinse.** Before the alodine solution dries, wipe it from the surface with a clean cloth or sponge wet with clean water. The alodine solution may also be rinsed from the surface with clean water from a hose.

**Dry.** After the rinsing has been finished, allow the work to air dry. Drying can be speeded by wiping with clean, dry rags. Clean, dry, compressed air should be used to blow moisture from joints, depressions, etc., and to speed the drying. When the surface is entirely dry, the part is ready for service without further treatment, or if desired, it may be painted in accordance with manufacturer's directions.

Refinish in accordance with WP 0039.

**CARGO BED COVER (CBC), TYPE III, 2 1/2 T CARGO TRUCK, LMTV, AND LMTV TRAILER 0023 00  
UNIT MAINTENANCE**

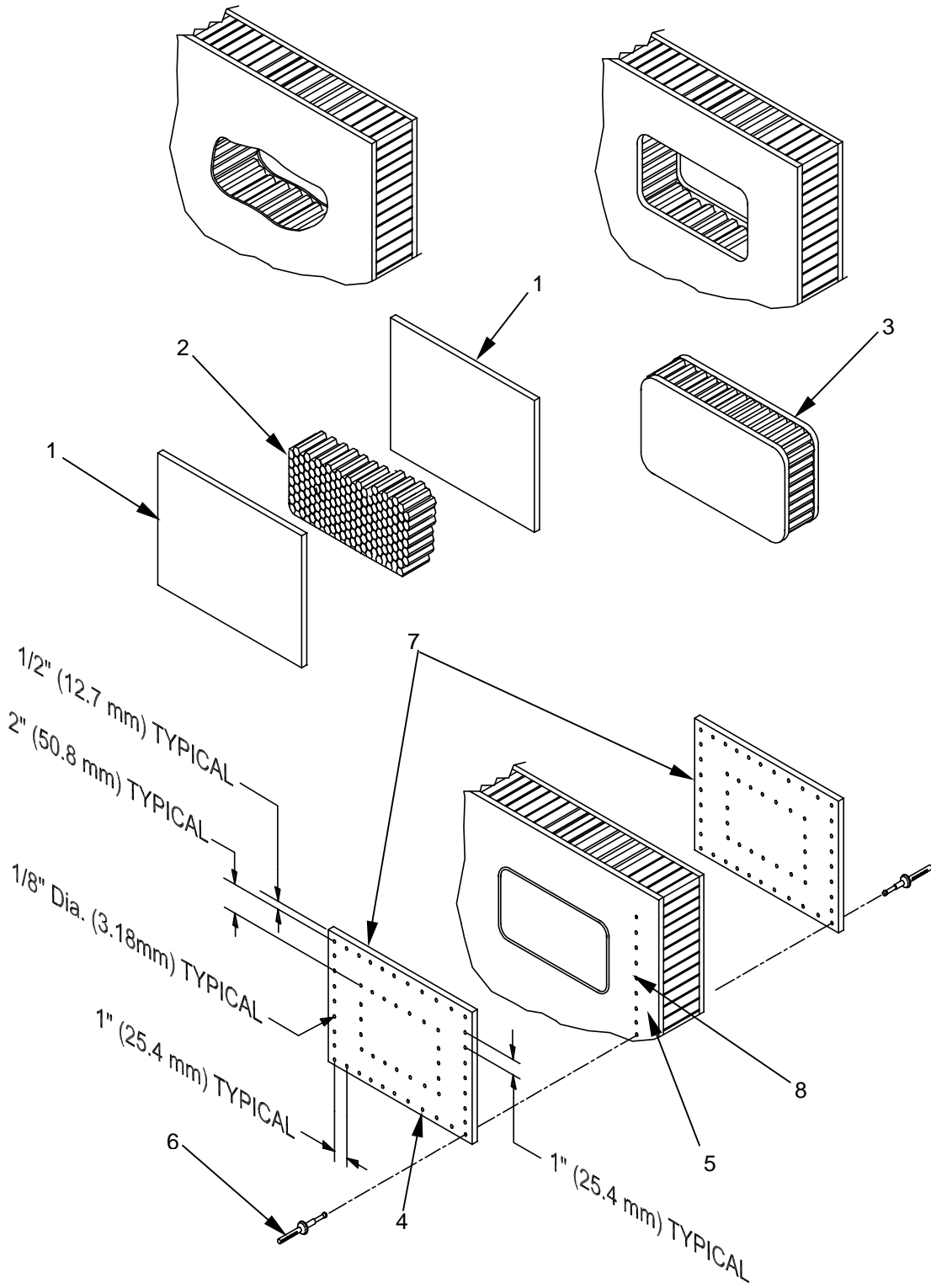

**END OF WORK PACKAGE**



**CARGO BED COVER (CBC), TYPE III, 2 1/2 T CARGO TRUCK, LMTV, AND LMTV TRAILER 0024 00  
UNIT MAINTENANCE**

**BLIND RIVET REMOVAL AND REPLACEMENT**

**THIS SECTION COVERS:**

Inspect, Remove, Replace

**INITIAL SETUP:**

**Personnel Required:** One

**Maintenance Level - Unit**

**Materials/Parts**

**Tools and Special Tools**

General Mechanic Tool Kit (WP 0041, Table 2, Item 1)  
Goggles, Industrial (WP 0041, Table 2, Item 3)  
Drill, Electric, Portable (WP 0041, Table 2, Item 4)  
Drill Set, Twist: W/25 Components And Metal Box, Numbered Series (WP 0041, Table 2, Item 8)  
Riveter, Blind, Hand with 1/8 inch nosepiece (WP 0041, Table 2, Item 9)  
Punch, Pin, 1/8 Inch Dia. (WP 0041, Table 2, Item 12)

Wiping Rags (WP 0055, Table 1, Item 6)  
Masking tape (WP 0055, Table 1, Item 5)  
Adhesive (WP 0055, Table 1, Item 9)  
Sealant, Type II (WP 0055, Table 1, Item 18)

**GENERAL**

This procedure contains information and instructions to keep the CBC weathertight and in good working order by inspecting and replacing defective blind rivets.

**INSPECT**

Inspect the blind rivets to ensure that they are not loose or missing. Remove and replace as described in the procedures that follow.

**REMOVE**

Remove defective blind rivets as follows:



Safety goggles must be worn during repair to protect eyes from flying metal chips. Failure to wear proper eye protection may result in eye injury and/or blindness.

Select a drill bit **(1)** that is the same diameter as installed blind rivet **(2)**.

Install selected drill in chuck.

Hold drill perpendicular to the surface to prevent enlargement or damage to existing hole.

**CARGO BED COVER (CBC), TYPE III, 2 1/2 T CARGO TRUCK, LMTV, AND LMTV TRAILER 0024 00  
UNIT MAINTENANCE**

Drill through center of rivet **(2)** just deep enough to sever the rivet head from shank.

Remove remainder of rivet with a pin punch.

Deburr rivet hole.

**REPLACE**

Install blind rivets as follows:

Select proper diameter and length of blind rivet **(2)** for the hole drilled above.

Select appropriate nose piece **(3)** for hand blind riveter **(4)** and install nose piece **(3)**.



**WARNING**

Two part sealant is flammable and toxic and shall be used only in a well-ventilated area away from all sparks or open flame. Gloves and safety goggles should be worn during use.



**NOTE**

Maximum application life of sealant is 2 hours.

Mix a small quantity of the sealant, in an open top container, sufficient for the repair being performed. The sealant is supplied as two components, part "A" and part "B". The two sealant components are different colors; part "A" is black and Part "B" is off white. The sealant is mixed in a ratio of 10:100 (Part "A":Part "B") by weight. This means, for example, that one ounce of Part "A" would require ten ounces of Part "B" to achieve a proper formulation. Before mixing the two components together, each component should be measured out and mixed separately to ensure that each component is uniform in color and consistency. Once the separate components are uniformly mixed, combine Part "A" and Part "B" together and mix the combination together in order to achieve a uniform dark grey color. Personnel should mix the two parts and ensure that there are no visible streaks of black or white.

Wet rivet with sealant and insert rivet in hole.

Holding hand blind riveter **(4)** at right angle to work, install on blind rivet stem **(5)**.

Push against work with just enough force to firmly seat rivet and prevent part separation.

Squeeze handle of hand blind riveter **(4)** and pull rivet until stem **(5)** breaks.

**CARGO BED COVER (CBC), TYPE III, 2 1/2 T CARGO TRUCK, LMTV, AND LMTV TRAILER 0024 00  
UNIT MAINTENANCE**

If necessary, trim broken stem flush with rivet head.

Firmly press on installed rivet to check tightness of installation.

Remove and replace in accordance with procedure if installation is unacceptable.

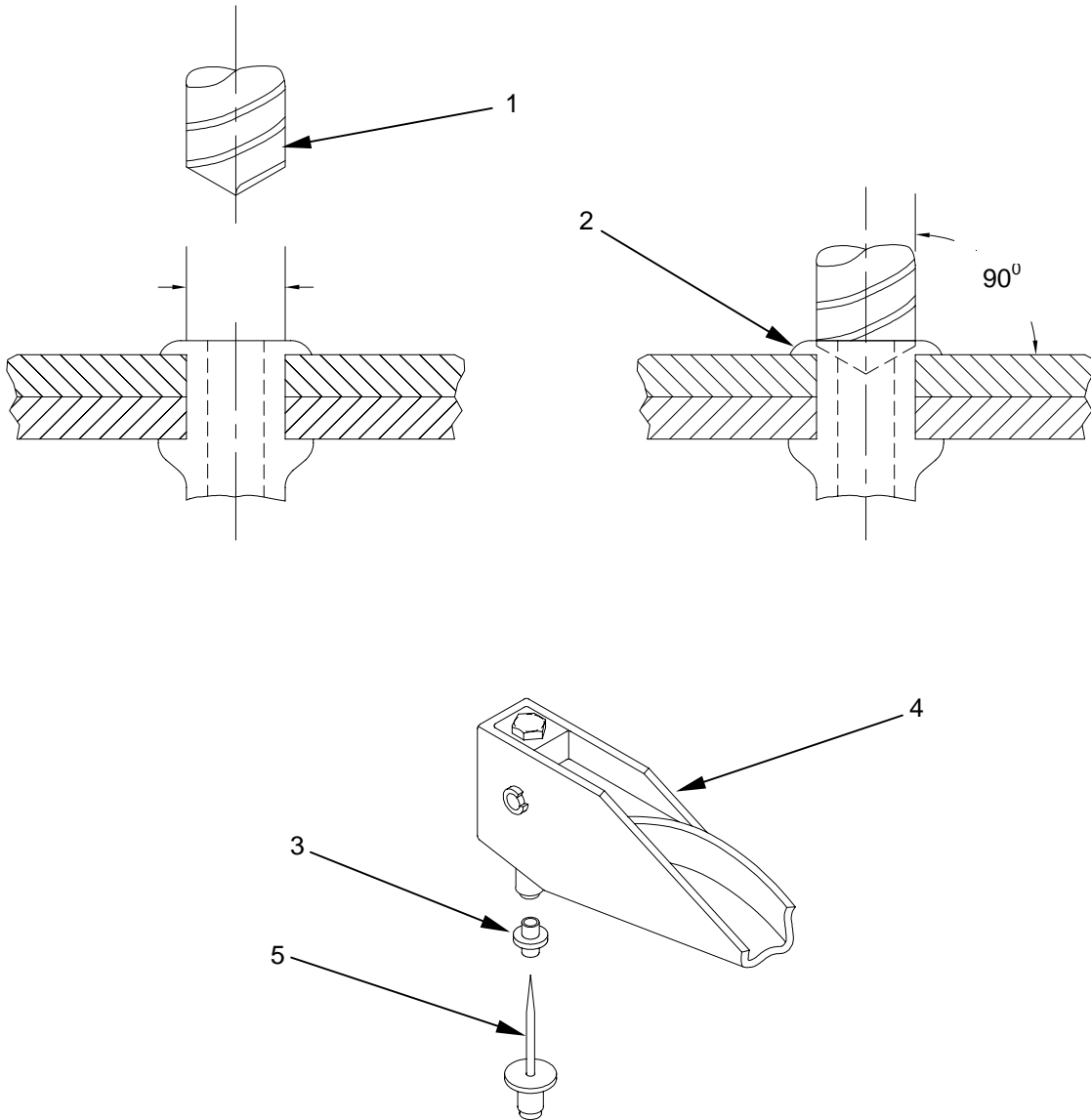

**END OF WORK PACKAGE**





**CARGO BED COVER (CBC), TYPE III, 2 1/2 T CARGO TRUCK, LMTV, AND LMTV TRAILER 0025 00  
UNIT MAINTENANCE**

**CAULKING REPAIRED SECTIONS**

**THIS SECTION COVERS:**

Repair

<b>INITIAL SETUP:</b>	<b>Personnel Required:</b> One
<b>Maintenance Level - Unit</b>	<b>Materials/Parts</b>
<b>Tools and Special Tools</b>	Methylethylketone (WP 0055, Table 1, Item 3)
General Mechanic Tool Kit (WP 0041, Table 2, Item 1)	Wiping Rags (WP 0055, Table 1, Item 6)
Gloves, Chemical And Oil Protective (WP 0041, Table 2, Item 6)	Cartridges, 1/10 Gallon, Empty (WP 0055, Table 1, Item 10)
Gun, Caulking (WP 0041, Table 2, Item 7)	Nozzle, 2 1/2 In Long With 1/8 In Orifice (WP 0055, Table 1, Item 11)
	Sticks, Mixing (WP 0055, Table 1, Item 14)
	Sealant, Type II (WP 0055, Table 1, Item 18)

**REPAIR**



**WARNING**

Methylethylketone is flammable and toxic and shall be used only in a well-ventilated area away from sparks or open flame. Gloves and safety goggles should be worn during use.

Just prior to application of sealing compound, clean surface (1) to be sealed with cloth dampened with solvent.

Dry with a clean cloth before solvent evaporates in order to prevent contamination.



**WARNING**

Two part sealant is flammable and toxic and shall be used only in a well-ventilated area away from all sparks or open flame. Gloves and safety goggles should be worn during use.



**NOTE**

Maximum application life of sealant is 2 hours.

Mix a small quantity of the sealant in an open top container sufficient for the repair being performed. The sealant is supplied as two components, part "A" and part "B". The two sealant components are different colors; part "A" is black and Part "B" is off white. The sealant is mixed in a ratio of 10:100 (Part "A":Part "B") by weight. This means, for example, that one ounce of Part "A" would require ten ounces of Part "B" to achieve a proper formulation. Before mixing the two components together, each component should be measured out and mixed separately to ensure that each component is uniform in color and consistency. Once the separate components are uniformly mixed, combine Part "A" and Part "B" together and mix the combination together in order to achieve a uniform dark grey color. Personnel should mix the two parts and ensure that there are no visible streaks of black or white.

Apply sealing compound with caulking gun (or putty knife) **(2)** in 1/8 inch (3.18 mm) minimum fillets **(3)**.

Let sealant cure completely. Nominal curing time is 72 hours at 75°F.

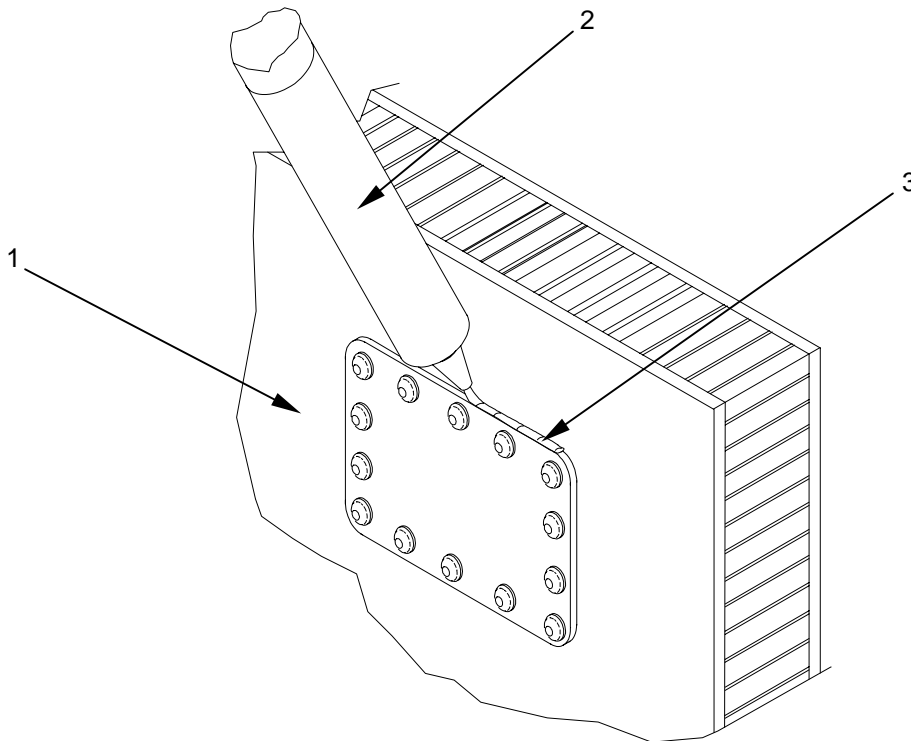

**END OF WORK PACKAGE**

**CARGO BED COVER (CBC), TYPE III, 2 1/2 T CARGO TRUCK, LMTV, AND LMTV TRAILER 0026 00 UNIT MAINTENANCE**

**THREADED INSERT REPLACEMENT**

**THIS SECTION COVERS:**

Replace

<b>INITIAL SETUP:</b>	<b>Personnel Required:</b> One
<b>Maintenance Level - Unit</b>	<b>Materials/Parts</b>
<b>Tools and Special Tools</b>	Methylethylketone (WP 0055, Table 1, Item 3)
General Mechanic Tool Kit (WP 0041, Table 2, Item 1)	Sandpaper (WP 0055, Table 1, Item 8)
Light, Incandescent Adjustable With Tripod Base (WP 0041, Table 2, Item 2)	Wiping Rags (WP 0055, Table 1, Item 6)
Goggles, Industrial (WP 0041, Table 2, Item 3)	Masking tape (WP 0055, Table 1, Item 5)
Drill, Electric, Portable (WP 0041, Table 2, Item 4)	Alodine, Brush (WP 0055, Table 1, Item 12)
Drill Set, Twist (WP 0041, Table 2, Item 5)	Adhesive, Two Part Epoxy (WP 0055, Table 1, Item 9)
Gloves, Chemical And Oil Protective (WP 0041, Table 2, Item 6)	Cartridges, 1/10 Gallon, Empty (WP 0055, Table 1, Item 10)
Gun, Caulking (WP 0041, Table 2, Item 7)	Nozzle, 2 1/2 In Long With 1/8 In Orifice (WP 0055, Table 1, Item 11)
Header, Hand-Operated (WP 0041, Table 2, Item 11 OR 13)	Sheet, Aluminum, .032 Inch Thick X 12 Inches X 12 Inches (WP 0055, Table 1, Item 15)
	Sticks, Mixing (WP 0055, Table 1, Item 14)
	Gloves, white, cloth (WP 0055, Table 1, Item 19)

**REPLACING NON-POTTED (NON ADHESIVE ENCAPSULATED) INSERTS**



**NOTE**

Inserts installed in extrusions are not potted. Knock out insert and replace with same type.

Depending on insert size, select a drill bit in size range listed below:

Insert Thread Size	Drill Size Range Inches (mm)
10-32	19/64 (7.6)
1/4-28	25/64 (9.9)
5/16-24	17/32 (13.5)
3/8-24	17/32 (13.5)



**WARNING**

Wear safety goggles for eye protection against flying chips.

Using selected drill bit **(1)**, drill head flange **(2)** from insert **(3)**. Knock out remaining portion of insert.

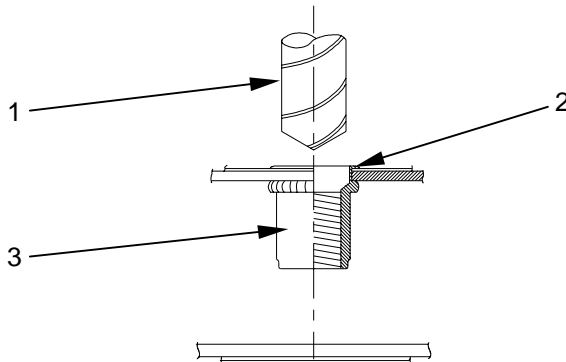

**Installing Threaded Inserts in Non-potted Areas (Edge Members, etc.)**

**CAUTION**

Always apply anti-sieze lubricant to bolt and screw threads before installation to prevent galling.

During the installation of threaded inserts, the threads inside the threaded insert can sometimes be damaged by the installation tool, and may result in the the bolts and screws binding. If this occurs, run a 5/16-18 UNF tap (included with the adapter kit) into the threaded area. This will clear and straighten the threads, making for easier and faster assembly. Care should be taken using this method since the tap has the ability to remove and/or cross thread existing threads. Be sure to work slowly and deliberately when clearing the threads.

Install the threaded insert using the appropriate hand operated threaded insert installation tool **(1)**, hex (allen) wrench **(2)** (included with installation tool), and 3/4 inch (or 1-1/16 inch depending on header tool used) wrench **(3)** (adjustable, fixed, or box end ratchet type).



**NOTE**

Before using the installation tool, inspect the condition of the jackscrew threads before use. If the tool has been used previously, the jackscrew threads may require a few drops of a light machine oil. If this is the initial use of the tool, no additional lubrication will be required.

To install a threaded insert, thread the threaded insert fastener **(4)** onto the threaded end **(5)** of the installation tool **(1)** included with the mounting kit. Be sure that the end of the installation tool is tight against the head of the fastener.

With the threaded insert **(4)** installed on the installation tool **(1)**, insert the threaded insert into the hole **(6)** on the panel **(7)**.

Insert the hex wrench **(2)** into the socket **(8)** at the top of the installation tool **(1)**. Insert the jaws of the adjustable or fixed wrench **(3)** on the flat-sided center section **(9)** of the installation tool **(1)**.

While holding the hex wrench **(2)** stationary and the installation tool **(1)** at a right angle to the panel **(7)**, turn the wrench **(3)** in a clockwise direction keeping track of the number of turns.

Turn the wrench **(3)** in a clockwise direction until firm resistance indicates that the fastener completely set, but no more than the maximum number of turns indicated below.

Thread Size	Maximum # of turns
10-32	1
1/4-28	1-1/2
5/16-24	1-3/4
3/8-24	1-1/2

Once the threaded insert is completely set, turn the wrench **(3)** in a counter-clockwise direction to break its grip with the threaded insert. Remove both wrenches **(2,3)** from the installation tool **(1)**.

Remove the threaded insert installation tool **(1)** from the threaded insert by turning the entire tool by hand in a counter-clockwise direction.

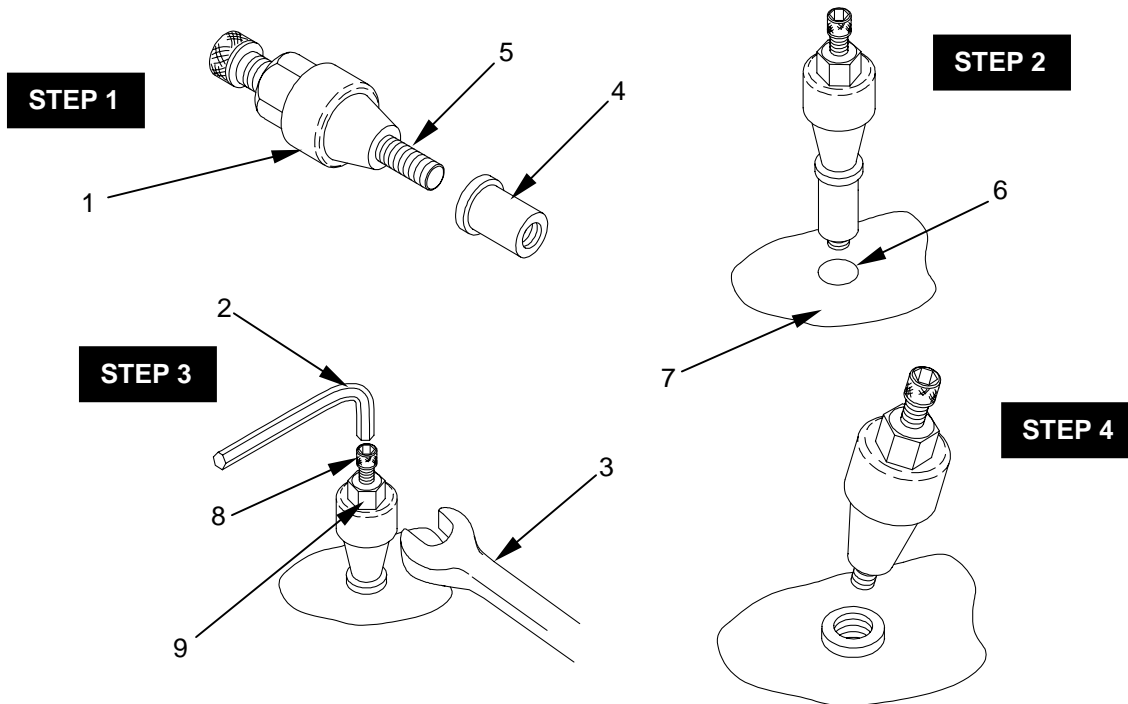

**REPLACING POTTED (ADHESIVE ENCAPSULATED) INSERTS**

**Removing damaged inserts**

Depending on insert size, select a drill bit in size range listed below:

Insert Thread Size	Drill Size Range Inches (mm)
10-32	19/64-21/64 (7.6-8.3)
1/4-28	25/64-27/64 (9.9-10.7)
5/16-24	17/32-9/16 (13.5-14.3)
3/8-24	17/32-9/16 (13.5-14.3)



Wear safety goggles for eye protection against flying chips.

Using selected drill bit, drill head flange (1) from insert (2).

Drill small holes (3) around insert body (4) in potting compound (5) to approximate depth of insert. Take care not to damage area around insert beyond hole diameter of the head flange (1) removed above. Do not drill through to opposite skin (6).

**CARGO BED COVER (CBC), TYPE III, 2 1/2 T CARGO TRUCK, LMTV, AND LMTV TRAILER 0026 00  
UNIT MAINTENANCE**

Install bolt of corresponding thread size in insert (2). The bolt is used to grab and break loose the damaged insert.

Use appropriate size wrench on bolt and break insert loose.

Install the head of the bolt end in the chuck of a power drill.

Spin loose insert to build up heat which will allow insert (2) to be removed from hole.

Remove loose chips and clean out hole.



**NOTE**

The replacement insert will not be like the original, it will be a spool-type potted insert.

Depending on replacement insert size, select a drill bit from sizes listed below. After drilling small holes around periphery of insert, the remaining hole will be much larger than the recommended drill size.

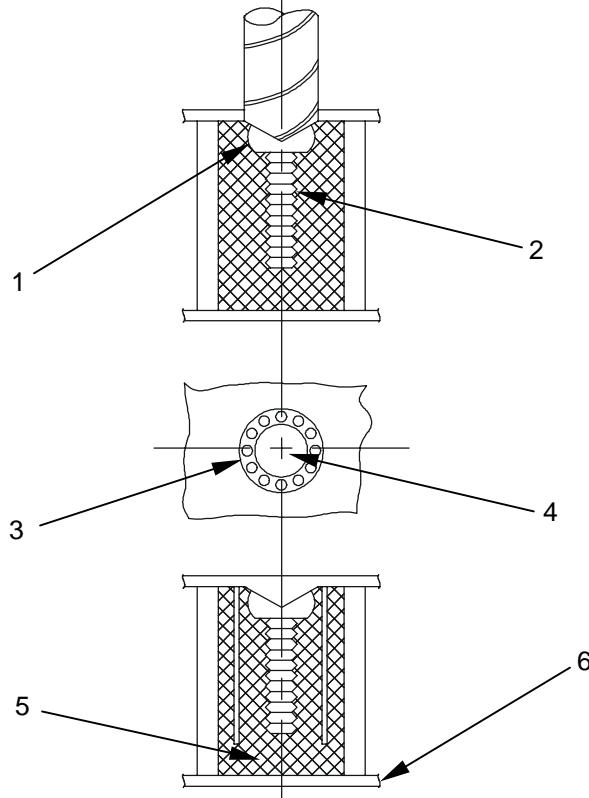

**CARGO BED COVER (CBC), TYPE III, 2 1/2 T CARGO TRUCK, LMTV, AND LMTV TRAILER 0026 00 UNIT MAINTENANCE**

**Preparing panel for replacement insert**

Depending on replacement insert size, select a drill bit in size range listed below:

Insert Thread Size	Diameter Inches (mm)	Drill Size Inches (mm)
1/4-28	0.437(11.1)	29/64 +/- 0.010 (11.5 +/- 0.25)
5/16-24	0.500 (12.7)	33/64 +/- 0.010 (13.1 +/- 0.25)
10-32 & 3/8-16	0.562 (14.3)	37/64 +/- 0.010 (14.7 +/- 0.25)
1/4-28 & 5/16-24	0.687 (17.5)	45/64 +/- 0.010 (17.9 +/- 0.25)
3/8-24	0.750 (19.1)	49/64 +/- 0.010 (19.5 +/- 0.25)

Using selected drill bit, drill through panel skin (1) to approximate depth of insert (2) to be installed.



**NOTE**

Take care not to drill through opposite skin.

Install long end of Allen key (3) into drill chuck (4) and insert short end (5) in pre-drilled hole (6) and remove additional honeycomb core (7) to one inch (2.54 cm) in diameter. Leave from 1/16 inch (3.2 mm) to 1/4 inch (6.5 mm) of core at bottom of hole.

Remove loose honeycomb from hole.

Degrease insert by cleaning with solvent.

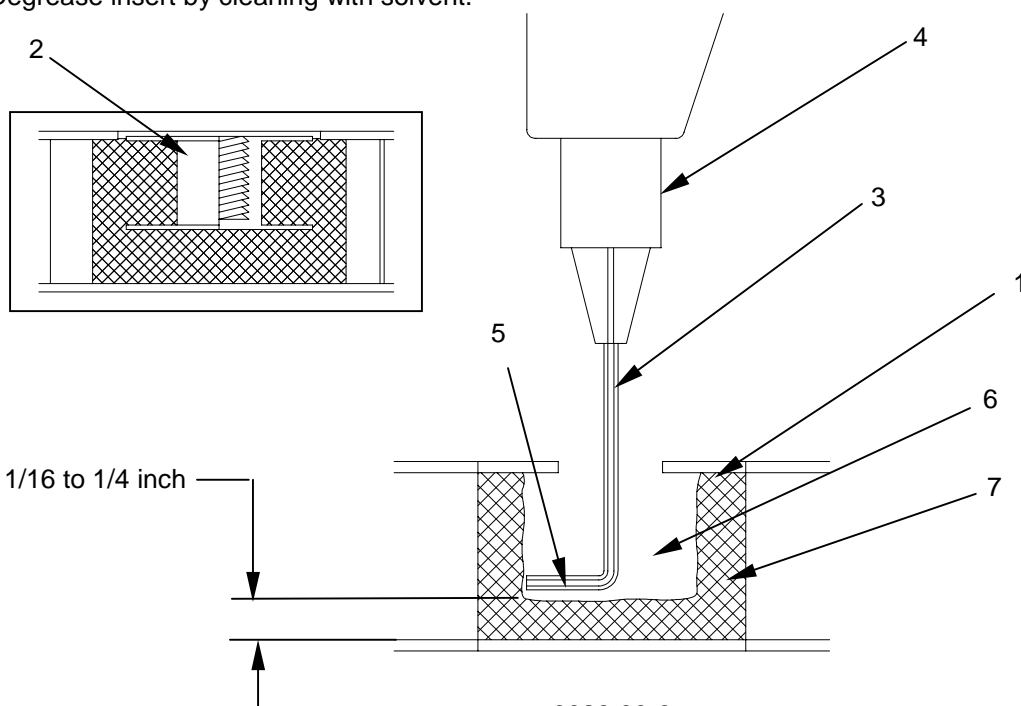



### Installing Replacement Insert



#### NOTE

After cleaning, handle insert with clean, white gloves.

Mask skin area around hole with masking tape approximately 3 inches x 3 inches.

Prepare aluminum plate **(3)** approximately 1/8 inch (3.2 mm) thick by 2 inches (50.8 mm) square with a center hole equal to bolt thread outer diameter (replacement insert thread size).

Install bolt **(4)** through plate and into insert **(5)**. Hand-tighten insert against plate **(3)**.

Mix a quantity of the adhesive in accordance with manufacturer's instructions, components (part "A" and part "B") in an open top container sufficient for the scope of the repair. The two adhesive components are different colors; part "A" is yellow and part "B" is blue. When properly and completely mixed, the color of the adhesive is green. Personnel should mix the two parts until the adhesive is a uniform green, with no streaks of yellow or blue.

Fill prepared hole **(1)** completely with mixed adhesive. Make sure there are no air pockets.

Force preassembled insert **(5)** into filled hole with a threading motion until plate **(3)** is flush against skin **(6)**.

Clean excess adhesive **(7)** (squeeze out) from work area.

Apply masking tape **(2)** over bolt **(4)** to maintain alignment during curing cycle.

Cure non-structural inserts for at least 4 hours at 75°F.

Inserts on which there is structural dependency should be cured at 75°F for 72 hours.

After cure, remove masking tape **(2)**, bolt **(4)** and plate **(3)**.

Clean skin as required.

**Apply alodine solution.** Apply the alodine solution with a brush, paint spray gun, cellulose sponge, etc., to the cleaned and rinsed aluminum surface, liberally, quickly and evenly. Allow it to act from 1 to 5 minutes before rinsing.



#### NOTE

The solution should be applied to only as much surface as can be coated and rinsed before the alodine solution dries.

TM 10-5411-233-13&P

**CARGO BED COVER (CBC), TYPE III, 2 1/2 T CARGO TRUCK, LMTV, AND LMTV TRAILER 0026 00  
UNIT MAINTENANCE**

Proceed with the coating and rinsing until the entire surface is coated with alodine.

**Rinse.** Before the alodine solution dries, wipe it from the surface with a clean cloth or sponge wet with clean water. The alodine solution may also be rinsed from the surface with clean water from a hose.

**Dry.** After the rinsing has been finished, allow the work to air dry. Drying can be speeded by wiping with clean, dry rags. Clean, dry, compressed air should be used to blow moisture from joints, depressions, etc., and to speed the drying. When the surface is entirely dry, the part is ready for service without further treatment, or if desired, it may be painted in accordance with manufacturer's directions.

Refinish in accordance with WP 0039.

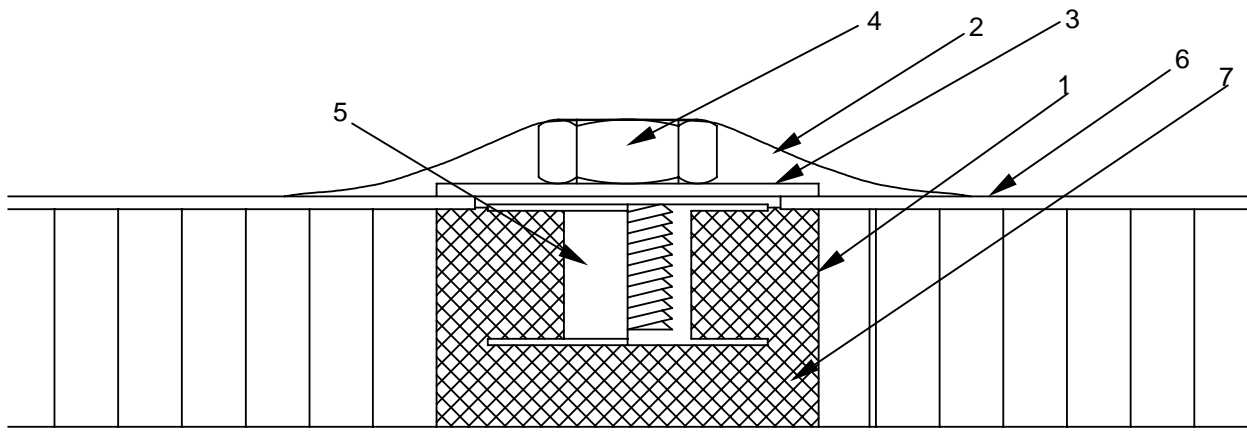

**END OF WORK PACKAGE**

---

**CARGO BED COVER (CBC), TYPE III, 2 1/2 T CARGO TRUCK, LMTV, AND LMTV TRAILER 0027 00  
UNIT MAINTENANCE**

---

**ROOF ACCESS HANDHOLD**

**THIS SECTION COVERS:**

Inspect, Remove, Replace

---

**INITIAL SETUP:**

**Personnel Required:** One

**Maintenance Level - Unit**

**Materials/Parts**

**Tools and Special Tools**

General Mechanic Tool Kit (WP 0041, Table 2,  
Item 1)

---

**GENERAL**

This procedure contains information and instructions to keep the CBC safe and in good working order by inspecting and replacing the roof access handhold.

**INSPECT**

Inspect the rubber gripping surface of the roof access handhold and ensure that there are no surfaces that could cut or otherwise injure a user's hand.

**REMOVE**

To remove the roof access handhold **(1)** remove the four screws **(2)**, lockwashers **(3)**, and flat washers **(4)** that secure the handhold **(1)** to the roof of the Cargo Bed Cover. Note that there is no hardware installed in the center hole **(5)** of the roof access handhold **(1)**.

Remove the defective handhold from the roof of the CBC.

**REPLACE**

Install a new handhold **(1)** in the same orientation as the original.

Install screws **(2)**, lockwashers **(3)**, and flat washers **(4)** in four locations to secure the new handhold to the roof of the CBC.

CARGO BED COVER (CBC), TYPE III, 2 1/2 T CARGO TRUCK, LMTV, AND LMTV TRAILER 0027 00  
UNIT MAINTENANCE

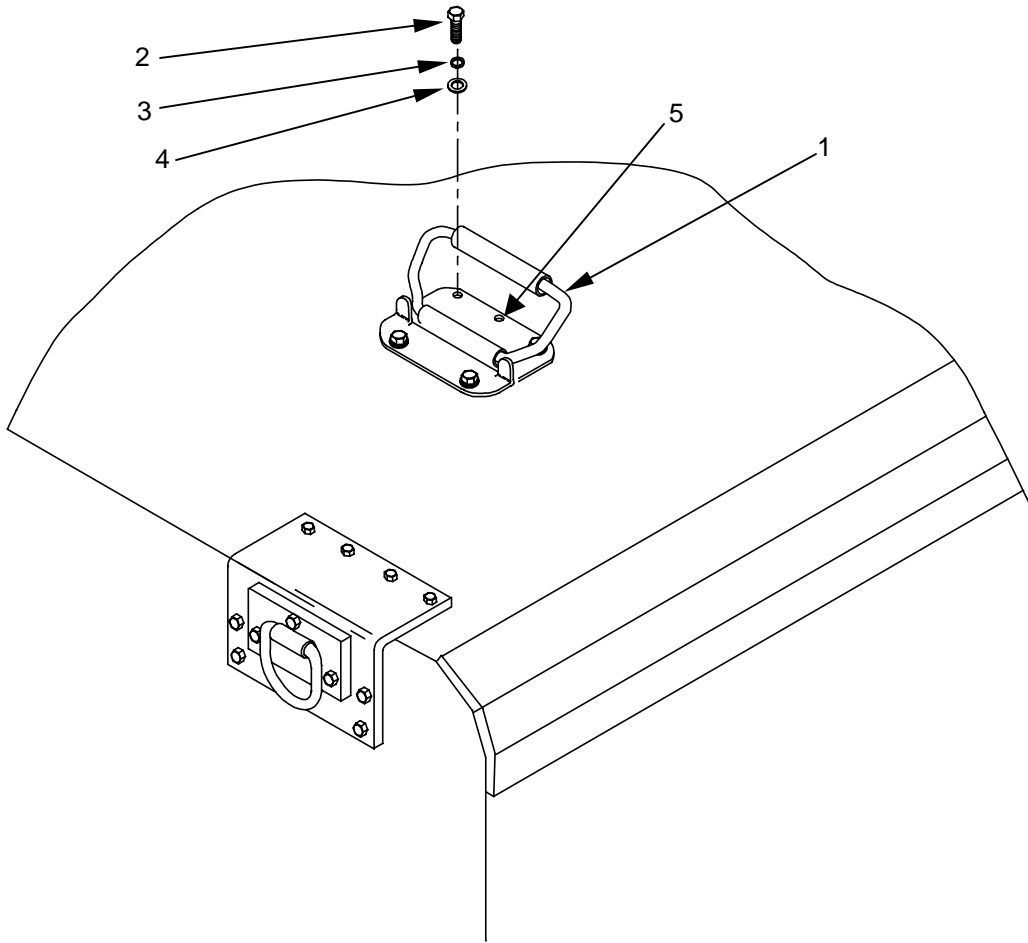

END OF WORK PACKAGE

---

**CARGO BED COVER (CBC), TYPE III, 2 1/2 T CARGO TRUCK, LMTV, AND LMTV TRAILER 0028 00  
UNIT MAINTENANCE**

---

**UPPER ROOF ACCESS STEP**

**THIS SECTION COVERS:**

Replace

---

**INITIAL SETUP:**

**Personnel Required:** One

**Maintenance Level - Unit**

**Materials/Parts**

**Tools and Special Tools**

General Mechanic Tool Kit (WP 0041, Table 2,  
Item 1)

---



**NOTE**

If replacing the lower roof access step, refer to WP 0033 for maintenance instructions.

**REPLACE**

To replace either of the two upper roof access steps **(1)**, remove the two hex head bolts **(2)** of the roof access step being replaced.

Loosen and remove the hex head bolts **(2)**, and lock washers **(3)**.

Remove the defective roof access step **(1)**.

Install a new roof access step **(1)** into position on the side wall of the CBC.

Align the holes on the roof access step with the holes on the side wall of the CBC.

Install the two lock washers **(3)** followed by the two hex head bolts **(2)** through the roof access step and into the threaded inserts **(4)** permanently installed in the side wall of the CBC.

Tighten both bolts securely.

**CARGO BED COVER (CBC), TYPE III, 2 1/2 T CARGO TRUCK, LMTV, AND LMTV TRAILER 0028 00  
UNIT MAINTENANCE**

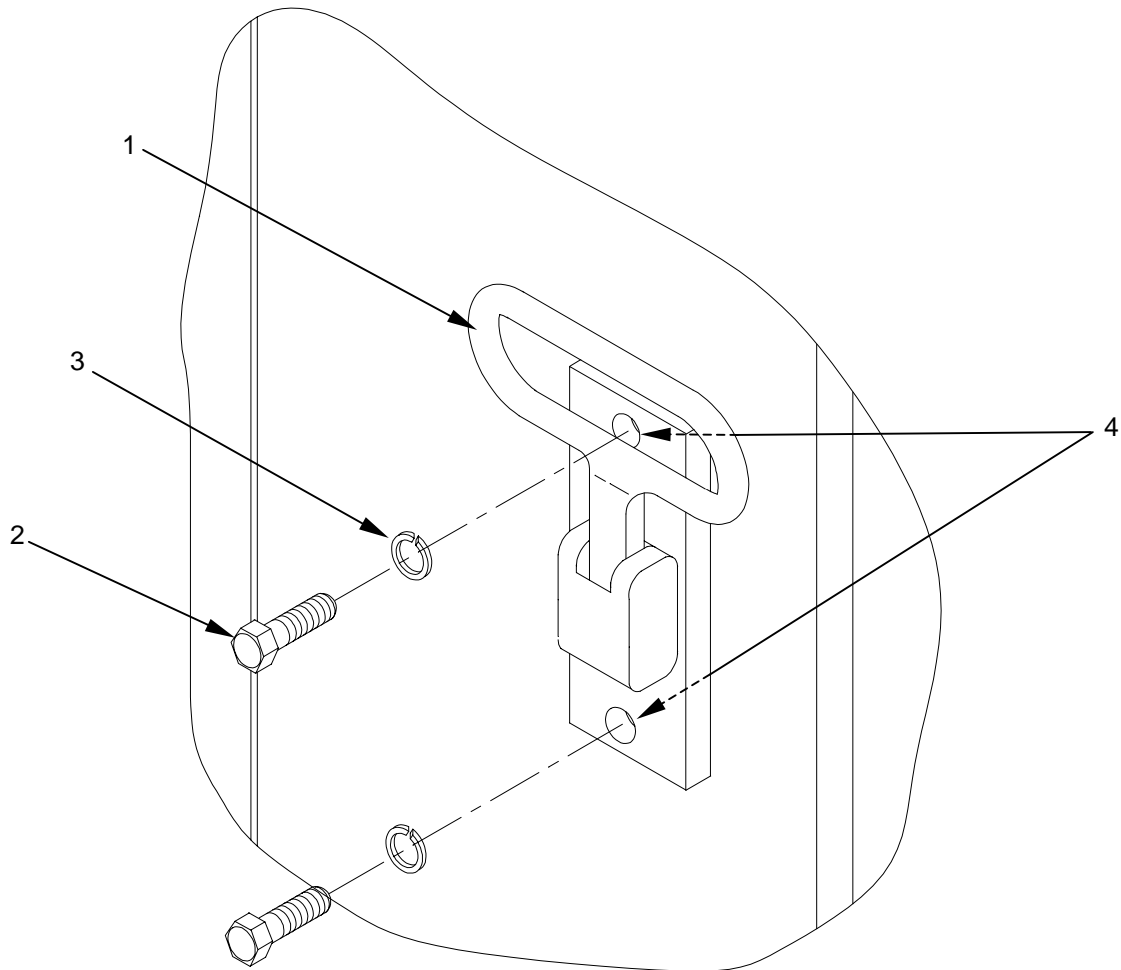

**END OF WORK PACKAGE**

---

**CARGO BED COVER (CBC), TYPE III, 2 1/2 T CARGO TRUCK, LMTV, AND LMTV TRAILER 0029 00  
UNIT MAINTENANCE**

---

**LIFTING RINGS**

**THIS SECTION COVERS:**

Inspect, Replace

---

**INITIAL SETUP:**

**Personnel Required:** One

**Maintenance Level - Unit**

**Materials/Parts**

**Tools and Special Tools**

General Mechanic Tool Kit (WP 0041, Table 2,  
Item 1)

---

**GENERAL**

This procedure contains information and instructions to keep the CBC safe and in good working order by inspecting and replacing the lifting ring assembly as required.

**INSPECT**

Inspect the lifting ring **(1)** to ensure that there are no cracks or other damage that could cause the lifting ring to fail upon lifting the CBC.

**REPLACE**

To replace any of the four lifting rings **(1)**, remove ten hex head bolts **(2)**, lockwashers **(3)**, and flat washers **(4)** securing the lifting ring assembly to the CBC.

Remove the defective lifting ring.

Install a new lifting ring **(1)** in position on the CBC and align mounting holes **(5)**.

Install 10 flat washers **(4)**, lock washers **(3)**, and hex head bolts **(2)** in the corresponding mounting hole positions.

TM 10-5411-233-13&P

**CARGO BED COVER (CBC), TYPE III, 2 1/2 T CARGO TRUCK, LMTV, AND LMTV TRAILER 0029 00  
UNIT MAINTENANCE**

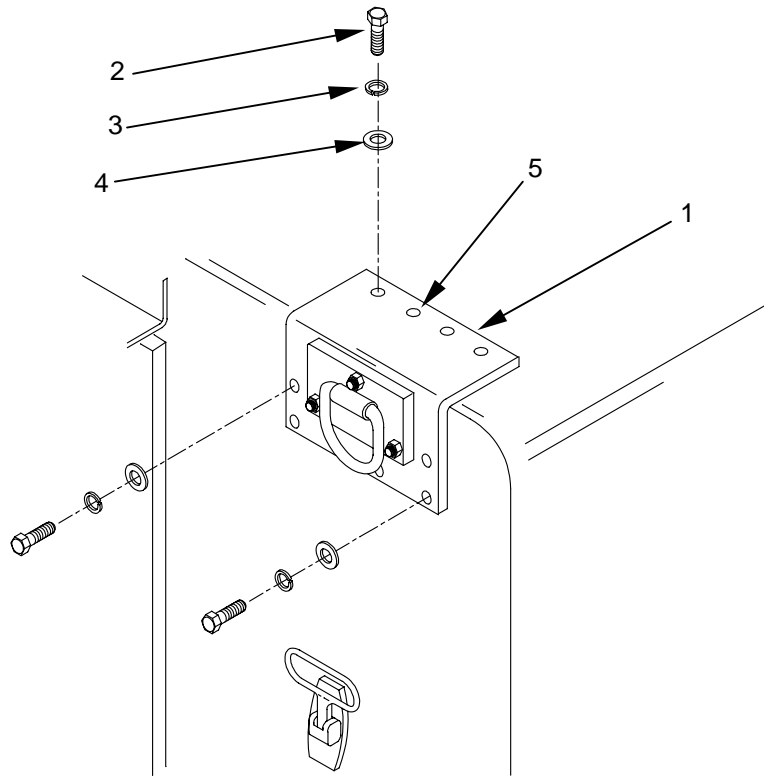

**END OF WORK PACKAGE**



---

**CARGO BED COVER (CBC), TYPE III, 2 1/2 T CARGO TRUCK, LMTV, AND LMTV TRAILER 0030 00  
UNIT MAINTENANCE**

---

**AIR FILTER**

**THIS SECTION COVERS:**

Inspect, Service, Replace

---

**INITIAL SETUP:**

**Personnel Required:** One

**Maintenance Level - Unit**

**Materials/Parts**

Detergent, Mild (WP 0055, Table 1, Item 7)

**Tools and Special Tools**

Rags, Wiping (WP 0055, Table 1, Item 6)

---

**GENERAL**

This procedure contains information and instructions to keep the CBC safe and in good working order by inspecting and replacing the air filter as required.

**INSPECT**

Inspect the condition of the air filter **(1)** to ensure that it is not dirty, clogged, or damaged in such a way as to impair the free flow of air into the CBC.

**SERVICE**

To clean the air filter **(1)** reach up under the ventilator port opening **(2)** and grasp the air filter material with both hands.

Pull the air filter **(1)** straight down while moving from left to right.

Continue until the filter **(1)** has been completely removed from the ventilator port **(2)**.

Wash the air filter material in clean, mildly soapy water until clean.

Allow the air filter to dry before replacing it in the ventilator.

If the air filter is very dirty and cannot be cleaned satisfactorily, replace it with a new filter.

**REPLACE**

Remove old air filter **(1)** as instructed above.

Replace with a new air filter by feeding one end of the filter up under the ventilator port **(2)** and pushing upwards. Be sure that the filter remains straight and does not fold while being pushed into position.

Continue to push the air filter up into the ventilator port until the entire air filter is securely in place.

TM 10-5411-233-13&P

CARGO BED COVER (CBC), TYPE III, 2 1/2 T CARGO TRUCK, LMTV, AND LMTV TRAILER 0030 00  
UNIT MAINTENANCE

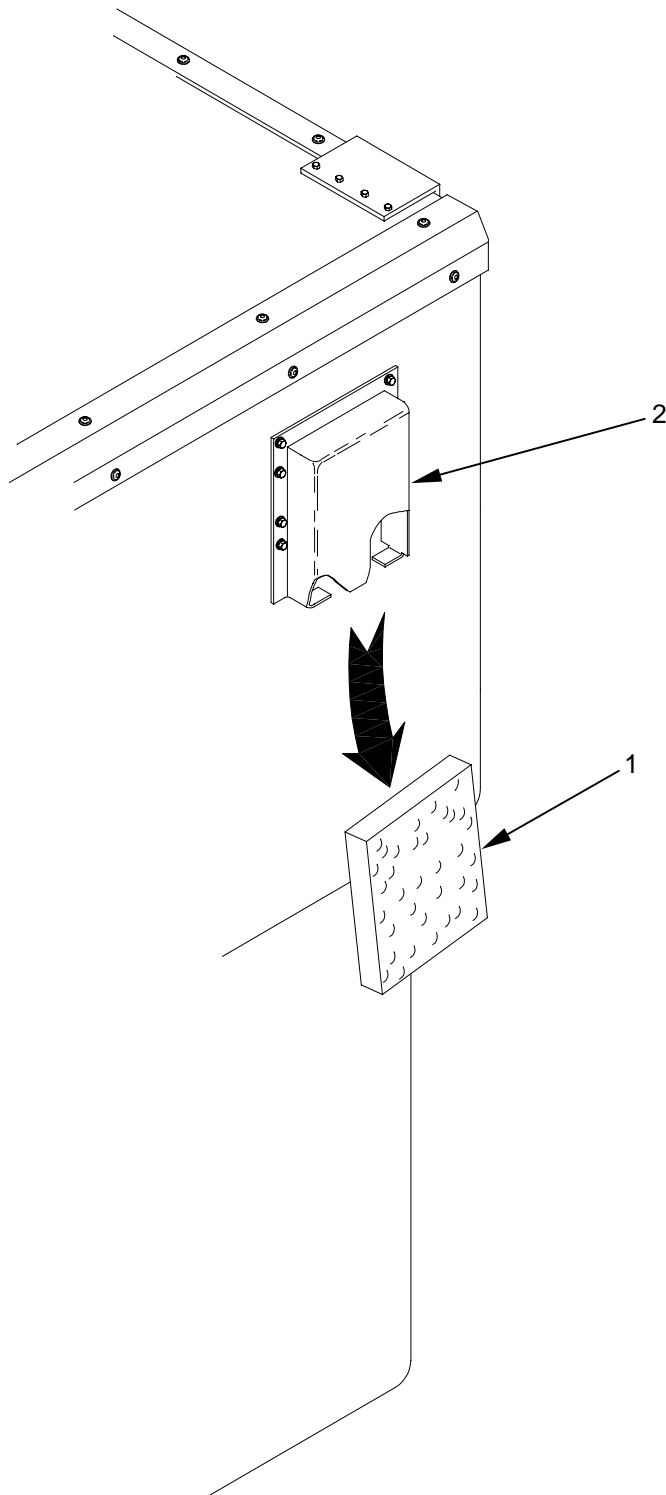

END OF WORK PACKAGE

0030 00-2

**CARGO BED COVER (CBC), TYPE III, 2 1/2 T CARGO TRUCK, LMTV, AND LMTV TRAILER 0031 00  
UNIT MAINTENANCE**

**LIFTING/LOCKING ASSEMBLY**

**THIS SECTION COVERS:**

Inspect, Replace

<p><b>INITIAL SETUP:</b> Lifting/Locking Assembly unlocked and disengaged from corner mounting (WP 0005) <b>Maintenance Level - Unit</b></p>	<p><b>Personnel Required:</b> One</p>
<p><b>Tools and Special Tools</b> General Mechanic Tool Kit (WP 0041, Table 2, Item 1)</p>	<p><b>Materials/Parts</b></p>

**GENERAL**

This procedure contains information and instructions to keep the CBC safe and in good working order by inspecting and replacing a defective lifting/locking assembly.

**INSPECT**

Inspect the lifting/locking assembly **(1)** to ensure that all parts of the assembly function properly and that there are no cracks or otherwise damaged parts that would prevent the lifting/locking assembly from operating properly and safely.

**REPLACE**

To remove the lifting/locking assembly **(1)**, remove the shoulder screw **(2)** and .032 inch thick x .562 inch O.D. flatwasher **(3)** and .065 inch thick x .734 inch O.D. flatwasher **(4)** that secures the assembly **(1)** to the roof **(5)** of the CBC.

Remove the entire assembly.

Install a new assembly **(1)** and align the hole **(6)** on the top of the lifting/locking assembly **(1)** with the hole **(7)** in the CBC roof **(5)**.

Install the shoulder screw **(2)**, .032 inch thick x .562 inch O.D. flatwasher **(3)** and .065 inch thick x .734 inch O.D. flatwasher **(4)**.

Tighten the shoulder screw **(2)** securely.

**CARGO BED COVER (CBC), TYPE III, 2 1/2 T CARGO TRUCK, LMTV, AND LMTV TRAILER 0031 00  
UNIT MAINTENANCE**

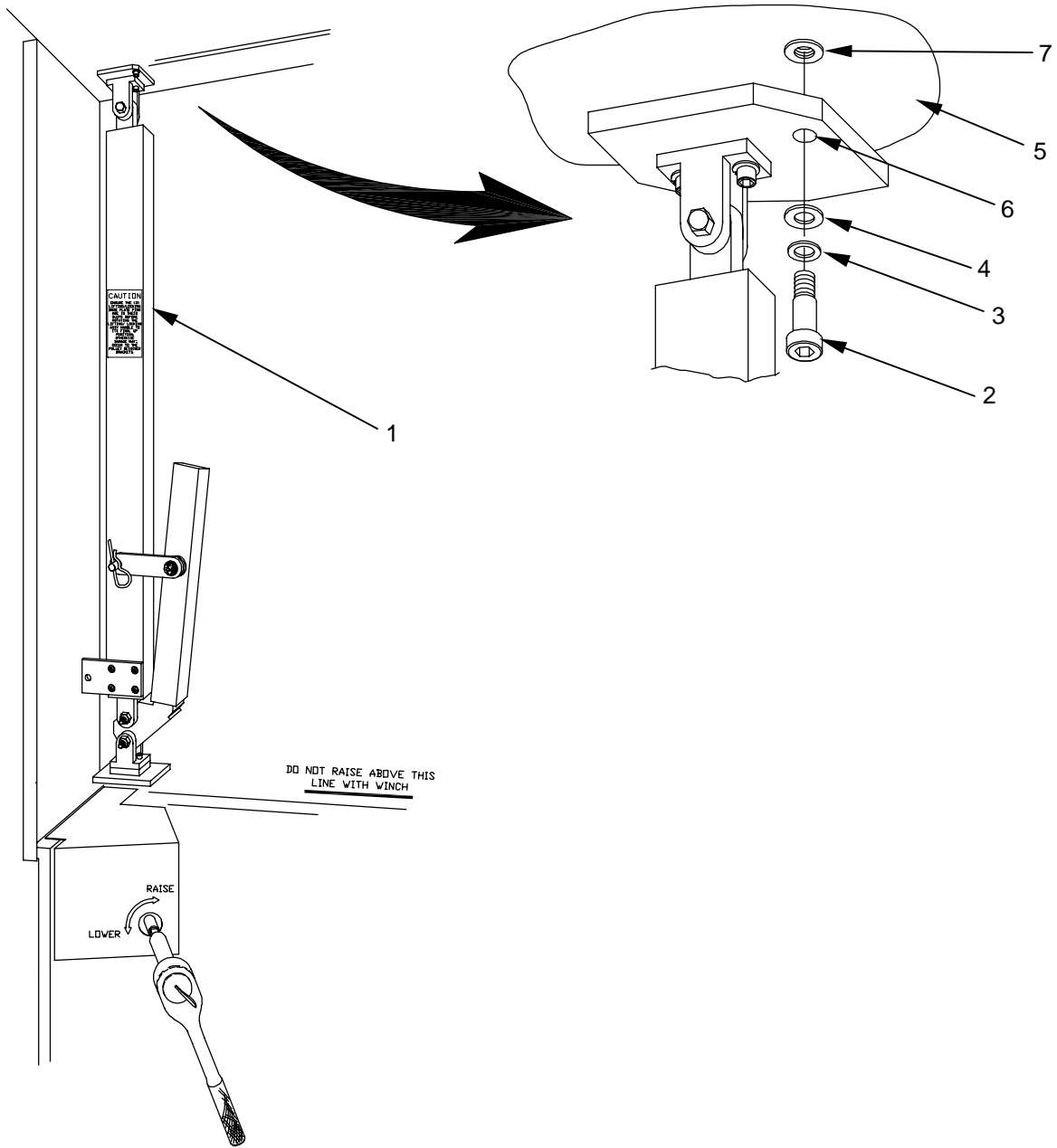

**END OF WORK PACKAGE**

**CARGO BED COVER (CBC), TYPE III, 2 1/2 T CARGO TRUCK, LMTV, AND LMTV TRAILER 0032 00  
UNIT MAINTENANCE**

**WINCH ASSEMBLY**

**THIS SECTION COVERS:**

Inspect, Replace

**INITIAL SETUP:**

CBC in fully extended position with all lifting/locking assemblies locked in place (WP 0005)

**Personnel Required:** One

**Maintenance Level - Unit**

**Materials/Parts**

**Tools and Special Tools**

General Mechanic Tool Kit (WP 0041, Table 2, Item 1)

**GENERAL**

This procedure contains information and instructions to keep the CBC safe and in good working order by inspecting and replacing a defective winch assembly.

**INSPECT**

Inspect the winch assembly **(1)** to ensure that all parts of the assembly function properly and that there are no cracks or other damaged parts that would prevent the winch assembly from operating properly and safely. To inspect the winch assembly **(1)**, remove the cover **(2)** as detailed below. Re-install the cover after inspection.

**REPLACE**

To replace the winch assembly **(1)**, remove the winch cover **(2)** by removing the four screws **(3)**, lockwashers **(4)**, and flat washers **(5)** that secure the cover **(2)**. Put the cover and its hardware aside.

Using a ratchet and/or by hand, unwind the cables **(16,17)** from the winch barrel **(7)**. Once the cables have been unwound, remove each cable assembly end ball **(8)** from its key-hole slot **(9)** in the outside plate **(10)** or middle plate **(11)**. It may require some force to pull and/or push the end ball through the keyhole slot. Take note of the relative positions of the cables. A small piece of tape marking the left and right cables is recommended.

After unwinding and removal of the cable assemblies **(6)** from the winch barrel **(7)**, remove the winch assembly **(1)** from the winch assembly bracket **(12)**, remove all hex locknuts **(13)**, flatwashers **(14)**, and hex head bolts **(15)** that secure the winch assembly **(1)** to the winch assembly bracket **(12)**.

Install a new winch assembly **(1)** in position onto the winch assembly bracket **(12)**, aligning the holes in each. Install all hex head bolts **(15)**, flat washers **(14)**, and locknuts **(13)**.

Rotate the winch barrel **(7)** to position the keyhole **(9)** located on the middle plate **(11)** at the top of the winch barrel.

Install the ball end **(8)** of the cable of the long right hand cable **(16)**, in the keyhole **(9)** located on the middle plate **(11)** of the winch barrel **(7)**.

**CARGO BED COVER (CBC), TYPE III, 2 1/2 T CARGO TRUCK, LMTV, AND LMTV TRAILER 0032 00 UNIT MAINTENANCE**

Slowly rotate the winch barrel (7) approximately 1/2 turn in order to position the keyhole (9) located on the left end plate (10) at the top of the winch barrel.

Install the left winch corner cable assembly (17) back onto the winch barrel (7) by inserting its ball end (8) into the key-hole slot (9) located in the outside (10) plate of the winch barrel (7). It may require some force to pull and/or push the end ball through the keyhole slot.

Using the ratchet, carefully wind the cables (16,17) onto the winch barrel (7). Make sure the cable ball ends (8) are firmly against the end of the small part of the key-hole slots (9) and remain parallel to one another and in a single layer as they wind onto the barrel.

Install the winch cover (2) by installing the four screws (3), lockwashers (4), and flat washers (5) that secure the cover (2).

Raise and lower the CBC upper section 2 to 3 times in order to re-tension the cables.

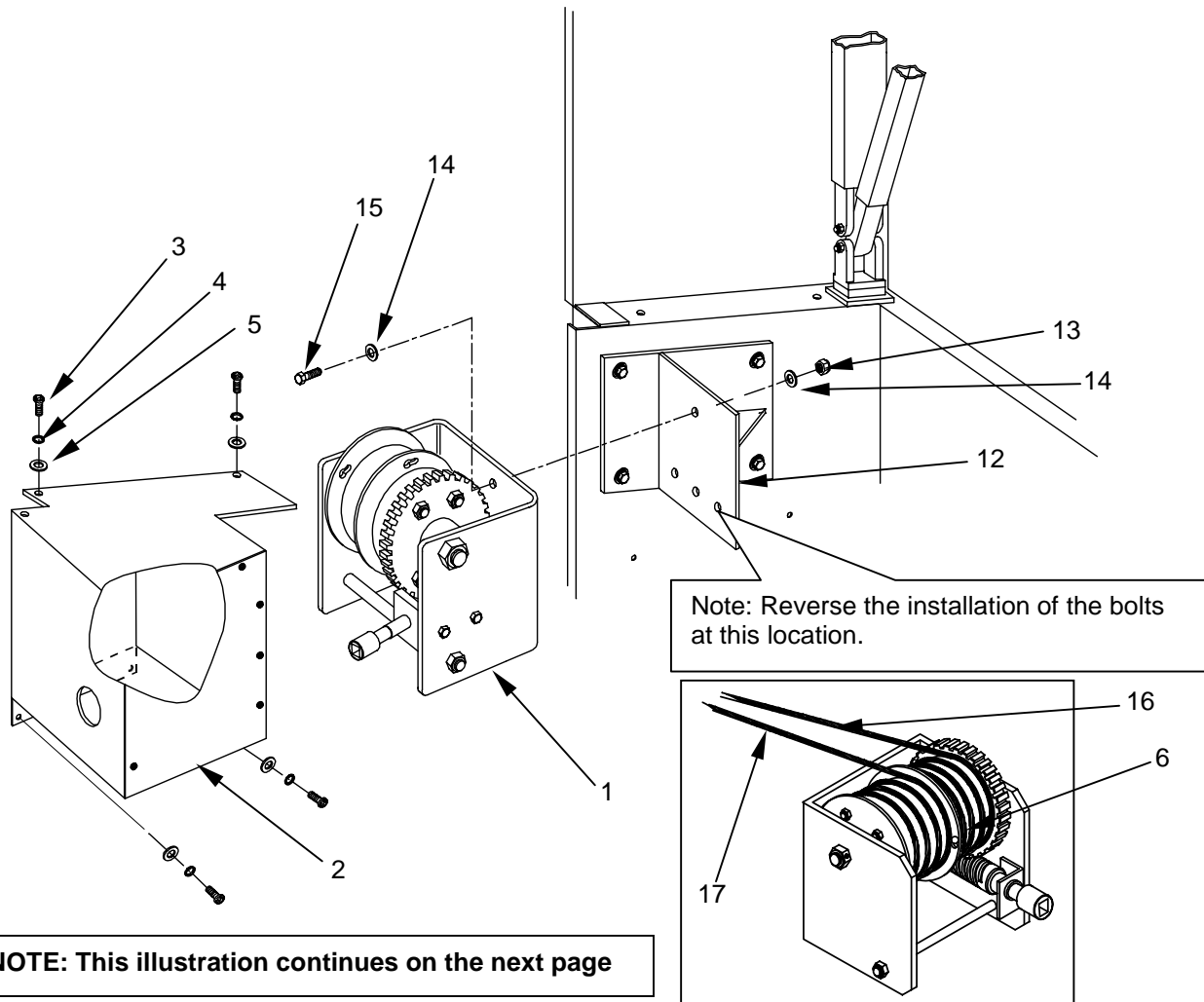

**CARGO BED COVER (CBC), TYPE III, 2 1/2 T CARGO TRUCK, LMTV, AND LMTV TRAILER 0032 00  
UNIT MAINTENANCE**

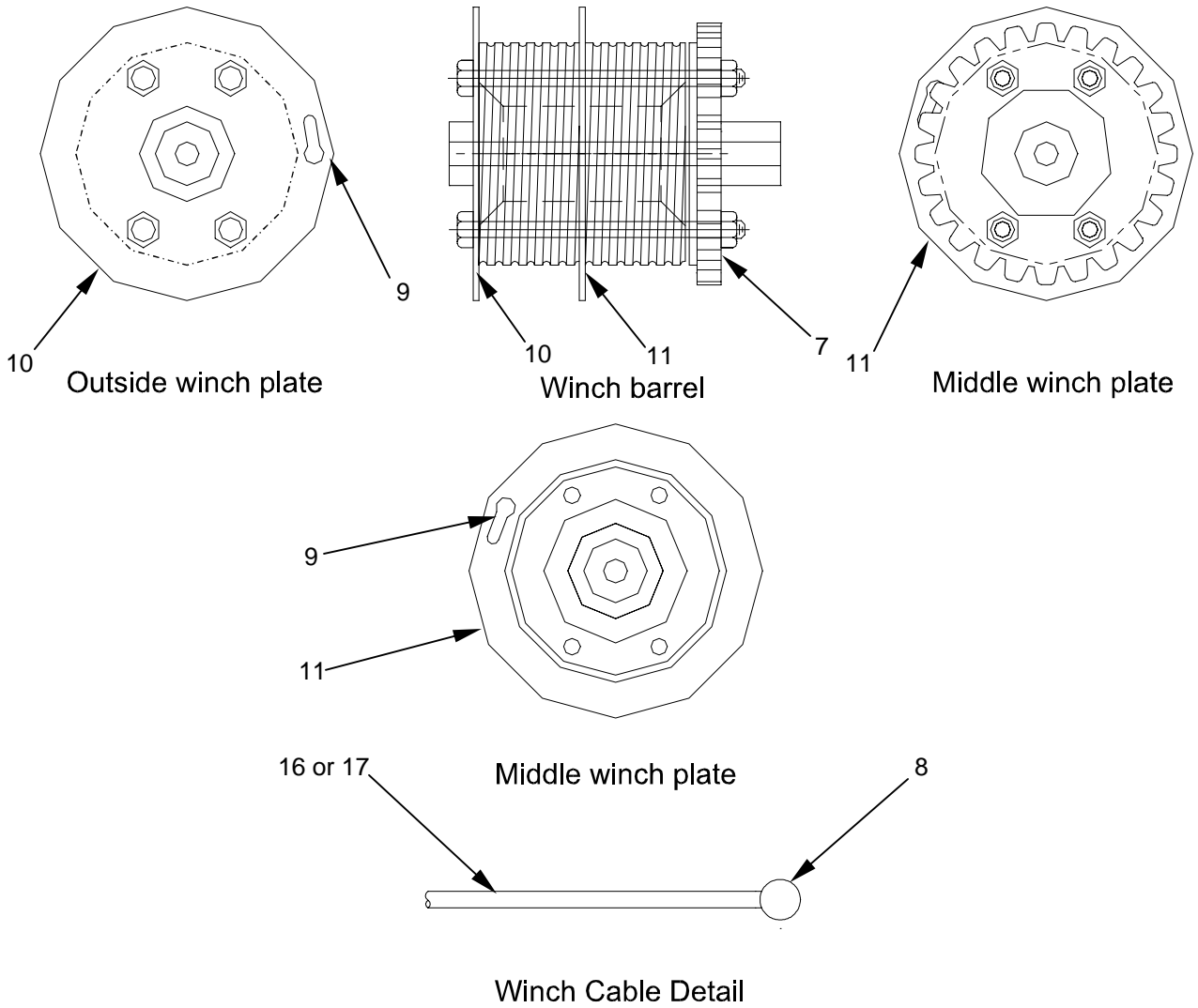

**END OF WORK PACKAGE**





---

**CARGO BED COVER (CBC), TYPE III, 2 1/2 T CARGO TRUCK, LMTV, AND LMTV TRAILER 0033 00  
UNIT MAINTENANCE**

---

**LOWER ROOF ACCESS STEP**

**THIS SECTION COVERS:**

Inspect, Replace

---

**INITIAL SETUP:**

**Personnel Required:** One

**Maintenance Level - Unit**

**Materials/Parts**

**Tools and Special Tools**

General Mechanic Tool Kit (WP 0041, Table 2,  
Item 1)

---

**GENERAL**

This procedure contains information and instructions to keep the CBC safe and in good working order by inspecting and replacing the lower roof access step.

**INSPECT**

Inspect the roof access step and ensure that there are no surfaces that are cracked or otherwise damaged that could prevent the step from performing in a safe manner.

**REPLACE**



**NOTE**

If replacing the upper roof access step, refer to WP 0028 for maintenance instructions.

To replace either of the lower roof access steps **(1)**, remove the two hex head bolts **(2)** located on the outside of the CBC.

While positioned in the opening of the personnel door, place a wrench on the hex locknut **(3)** on the inside of the CBC while placing a second wrench on the head of the hex head bolt **(2)** located on the outside of the CBC.

Loosen and remove the hex head bolt **(2)**, flatwasher **(4)**, and locknut **(3)**.

Remove the defective roof access step **(1)**.

Install a new roof access step **(1)** into position in the recessed mounting plate in the side wall of the CBC.

Align the holes on the roof access step with the holes on the side wall recessed mounting plate of the CBC.

Install the two hex head bolts **(2)** through the step and side wall from the outside of the CBC.

**CARGO BED COVER (CBC), TYPE III, 2 1/2 T CARGO TRUCK, LMTV, AND LMTV TRAILER 0033 00  
UNIT MAINTENANCE**

While positioned in the personnel door opening, place a wrench on the head of the hex head bolt **(2)**.

Install a flat washer **(4)** and hex locknut **(3)** on the opposite end of the bolt located inside the CBC.

While holding the hex head bolt **(2)** in position, tighten the hex locknut **(3)** securely.

Repeat for the second hex head bolt.

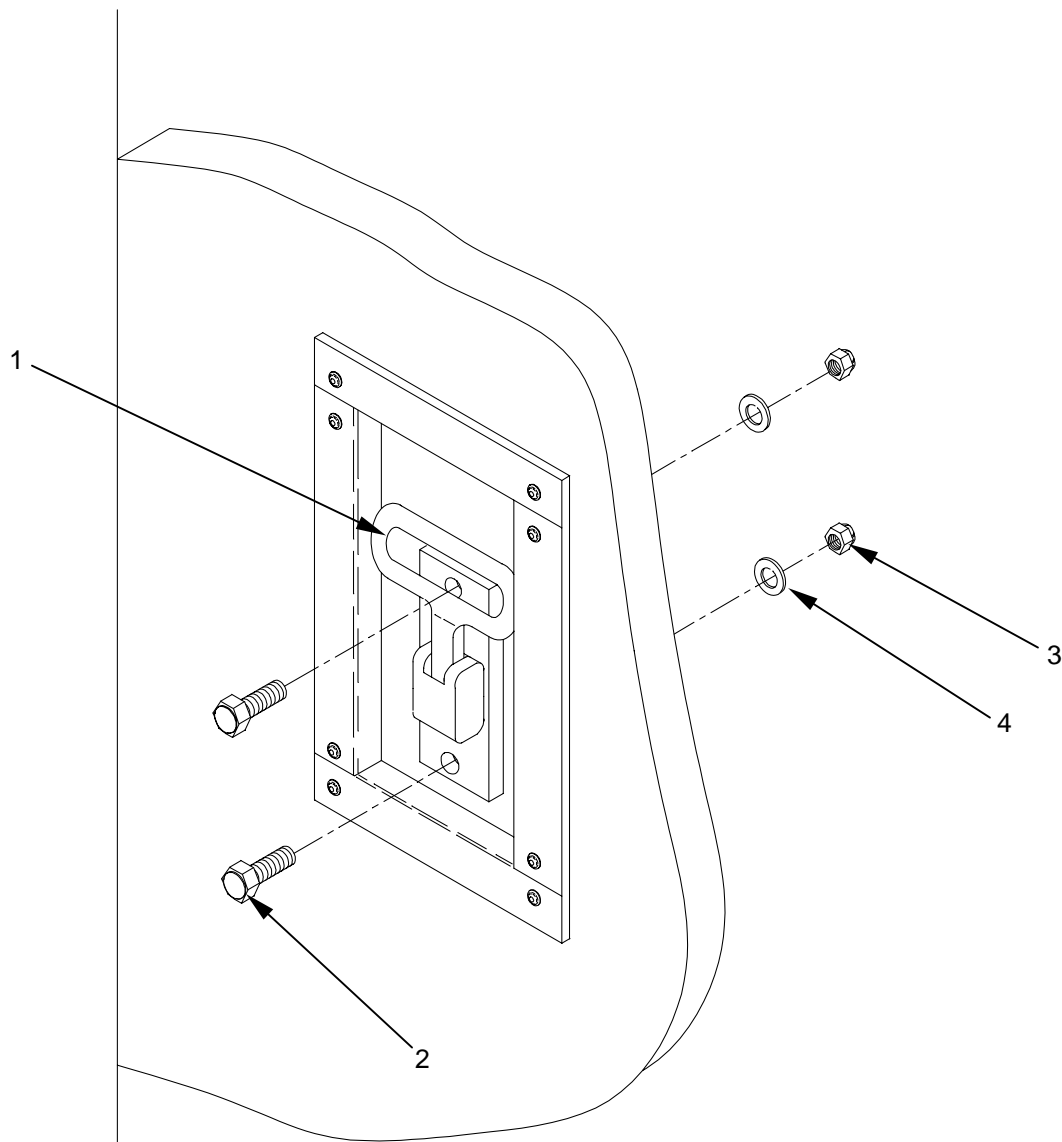

**END OF WORK PACKAGE**

---

**CARGO BED COVER (CBC), TYPE III, 2 1/2 T CARGO TRUCK, LMTV, AND LMTV TRAILER 0034 00  
UNIT MAINTENANCE**

---

**CARRIER MOUNTING ANGLE**

**THIS SECTION COVERS:**

Inspect, Replace

---

**INITIAL SETUP:**

**Personnel Required:** One

**Maintenance Level - Unit**

**Materials/Parts**

**Tools and Special Tools**

General Mechanic Tool Kit (WP 0041, Table 2,  
Item 1)

---

**GENERAL**

This procedure contains information and instructions to keep the CBC safe and in good working order by inspecting and replacing a defective carrier mounting angle.

**INSPECT**

Inspect the carrier mounting angle **(1)** to ensure that all securing hardware is in place and that there are no cracks, bends, or otherwise damaged parts that would prevent the carrier mounting angle from properly securing the CBC to the mounting plate or the vehicle bed.

Also inspect the condition of the CBC sidewall to ensure that it was not damaged in such a way as to prevent the proper installation of a new carrier mounting angle. If the sidewall is damaged, it must be repaired in accordance with the work packages in this manual dealing with sidewall repair.

**REPLACE**

To remove a damaged carrier mounting angle **(1)**, remove all hex bolts **(2)**, lock washers **(3)**, and flat washers **(4)** that are securing the damaged carrier mounting angle.

Remove the damaged carrier mounting angle **(1)**.

Install the new carrier mounting angle by aligning the holes **(5)** in the angle with the holes **(6)** on the side wall **(7)** of the CBC.

Install hex bolts **(2)**, lock washers **(3)**, and flat washers **(4)** in all mounting holes.

Tighten securely.

CARGO BED COVER (CBC), TYPE III, 2 1/2 T CARGO TRUCK, LMTV, AND LMTV TRAILER 0034 00  
UNIT MAINTENANCE

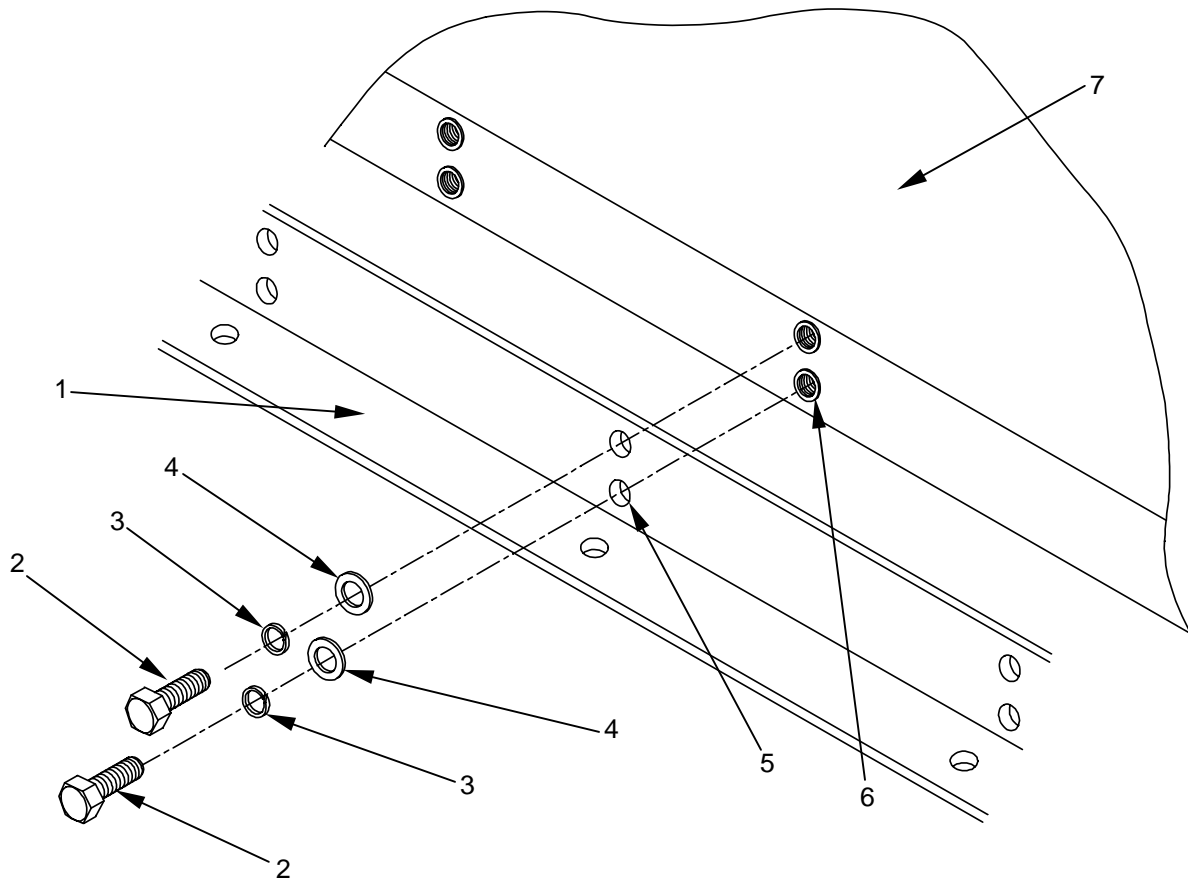

END OF WORK PACKAGE

**CARGO BED COVER (CBC), TYPE III, 2 1/2 T CARGO TRUCK, LMTV, AND LMTV TRAILER 0035 00  
UNIT MAINTENANCE**

**PERSONNEL DOOR WEATHER STRIPPING**

**THIS SECTION COVERS:**

Inspect, Replace

<p><b>INITIAL SETUP:</b> CBC fully extended and locked position <b>Maintenance Level - Unit</b></p>	<p><b>Personnel Required:</b> One</p>
<p><b>Tools and Special Tools</b> General Mechanic Tool Kit (WP 0041, Table 2, Item 1) Gloves, Chemical And Oil Protective (WP 0041, Table 2, Item 6)</p>	<p><b>Materials/Parts</b> Sandpaper, 100 Grit (WP 0055, Table 1, Item 8) Rags, Wiping (WP 0055, Table 1, Item 6) Solvent, Methyleneethylketone (WP 0055, Table 1, Item 3) Adhesive, (WP 0055, Table 1, Item 20)  Catalyst, (WP 0055, Table 1, Item 21) Sticks, Mixing (WP 0055, Table 1, Item 14)</p>

**GENERAL**

This procedure contains information and instructions to keep the CBC safe and in good working order by inspecting and replacing a defective personnel door weather stripping.

**INSPECT**

Inspect the personnel door weather stripping **(1)** to ensure that it is fully attached to the upper and lower personnel door opening frame members. Make sure that the weather stripping for both the upper **(2)** and lower **(3)** door sections is not torn or otherwise damaged that would prevent the personnel door from sealing properly and/or not preventing outside debris from entering the CBC.

**REPLACE**

Remove defective seal **(1)** and strip old adhesive from bonding surface **(4)**.



Methyleneethylketone is flammable and toxic and shall be used only in a well-ventilated area away from all sparks or open flame. Gloves and safety goggles should be worn during use.

Sand using sandpaper only if required to remove material not taken off in preceding step.

Wipe bonding surface **(4)** with a clean cloth dampened with solvent and immediately wipe solvent from surface with a clean, dry cloth.

**CARGO BED COVER (CBC), TYPE III, 2 1/2 T CARGO TRUCK, LMTV, AND LMTV TRAILER 0035 00  
UNIT MAINTENANCE**

**CAUTION**

Seals shall not be washed with any aromatic hydrocarbon (such as benzene, toluene, methylethylketone or xylene) which will cause deterioration.

Clean seal **(1)** with a lint-free cloth by dry wiping prior to bonding.



**WARNING**

Two part sealant is flammable and toxic and shall be used only in a well-ventilated area away from all sparks or open flame. Gloves and safety goggles should be worn during use.



**NOTE**

Maximum application life of adhesive is 2 hours.

Mix a small quantity of SILGRIP PSA529 silicone pressure sensitive adhesive in the ratio of 100 parts by weight with SRC18 Catalyst for SILGRIP silicone pressure sensitive adhesive 3.3 parts by weight. SRC-18 catalyst should be added to the adhesive and stirred well.

Brush adhesive on mating surfaces of seal **(1)** and bonding surface **(4)**.

When adhesive is tacky (approximately 5 minutes), place seal in position, press firmly to seat and ensure contact with mating surface.

**CARGO BED COVER (CBC), TYPE III, 2 1/2 T CARGO TRUCK, LMTV, AND LMTV TRAILER 0035 00  
UNIT MAINTENANCE**

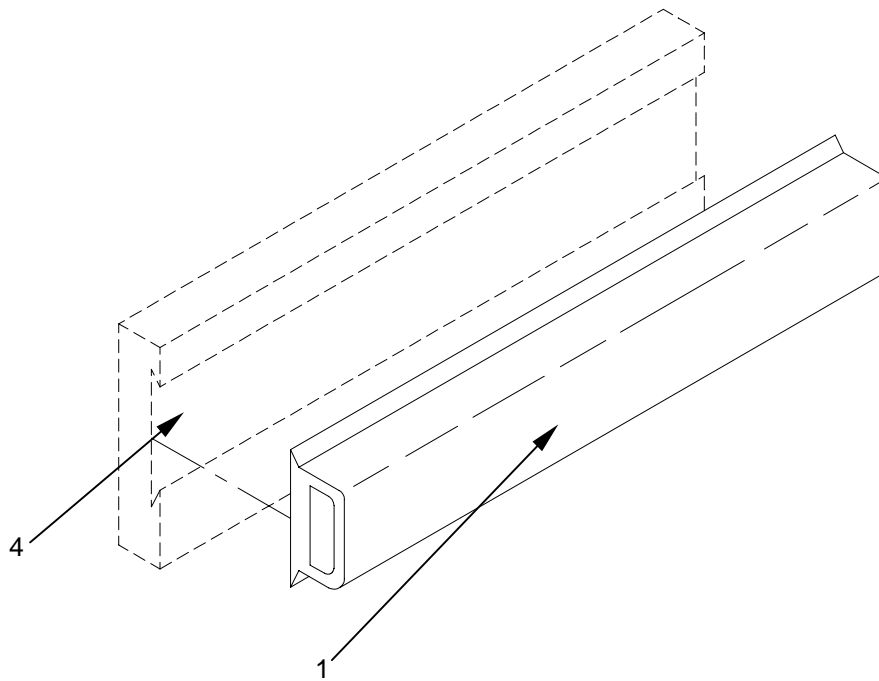
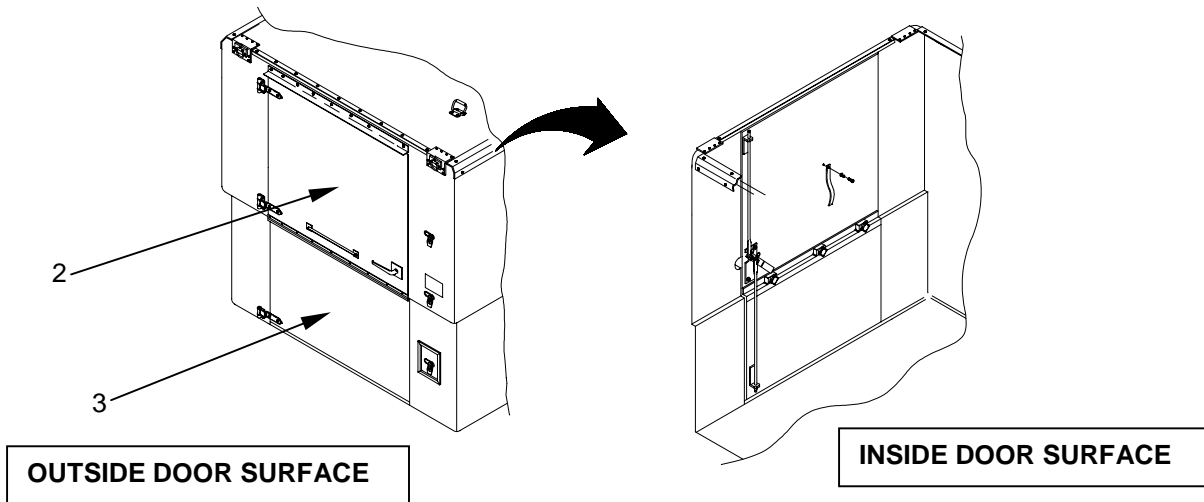

**END OF WORK PACKAGE**





**CARGO BED COVER (CBC), TYPE III, 2 1/2 T CARGO TRUCK, LMTV, AND LMTV TRAILER 0036 00  
UNIT MAINTENANCE**

**UPPER AND LOWER PERSONNEL DOOR**

**THIS SECTION COVERS:**

Inspect, Replace

<b>INITIAL SETUP:</b>	<b>Personnel Required:</b> One
<b>Maintenance Level - Unit</b>	<b>Materials/Parts</b>
<b>Tools and Special Tools</b>	
General Mechanic Tool Kit (WP 0041, Table 2, Item 1)	

**GENERAL**

This procedure contains information and instructions to keep the CBC safe and in good working order by inspecting and replacing a defective upper or lower personnel door.

**INSPECT**

Inspect the upper **(1)** and lower **(2)** personnel door to ensure that all parts of the assembly function properly. Make sure that the door latch assembly **(3)** operates properly and that there are no cracks or otherwise damaged parts that would prevent the personnel door from operating properly and safely.

**REPLACE**

To replace the lower personnel door **(2)**, remove the two hex head bolts **(4)**, lockwashers **(5)**, and flat washers **(6)** that secure the lower door hinge **(7)** of the lower door section **(2)** to the side wall of the CBC.

Open the door and remove the hairpin cotter **(8)** that secures the lower door rod **(9)** to the inner door handle **(10)**.

Remove the lower door rod **(9)** and set aside.

Be sure to support the lower door section **(2)** with a free hand and remove the three hand knobs **(11)** with lockwashers **(19)** that secure the lower door **(2)** to the upper door **(1)**. Set the three knobs and lockwashers aside.

Remove the lower personnel door **(2)**.

Install a new lower personnel door **(2)** by putting the section into position under the upper section **(1)** and aligning the three hand knob mounting holes.

Install and tighten the three hand knobs **(11)** with lockwashers **(19)**.

Install the lower door rod **(9)** in position through the two lower door guides **(12)** and install the hairpin cotter **(8)** removed earlier.

Transfer the lower door hinge **(7)** from the defective door (only if the hinge is not damaged in any way) to the new lower door section. Secure with hex head bolts **(4)**, flat washers **(6)**, and lock washers **(5)**,

**TM 10-5411-233-13&P**

---

**CARGO BED COVER (CBC), TYPE III, 2 1/2 T CARGO TRUCK, LMTV, AND LMTV TRAILER 0036 00  
UNIT MAINTENANCE**

---

installing two washers (one .09 inch thick and one 062 inch thick) **(17)** under the hinge nearest the door edge and one additional flat washer (.062 inch thick) **(18)** under the hinge furthest from the door edge.

Tighten all hardware securely.

To replace the upper personnel door **(1)**, remove the lower door section **(2)** as described previously and remove the hex head bolts **(13)**, lock washers **(14)**, and flat washers **(15)** that secure the door hinges **(16)** attached to the upper door **(1)**.

Place the new upper door into position and align the hinge mounting holes. Install the hex bolts **(13)**, lockwashers **(14)**, and flat washers **(15)**, installing two washers (one .09 inch thick and one 062 inch thick) **(17)** under the hinge nearest the door edge and one additional flat washer (.062 inch thick) **(18)** under the hinge furthest from the door edge.

Tighten all hardware securely.

**CARGO BED COVER (CBC), TYPE III, 2 1/2 T CARGO TRUCK, LMTV, AND LMTV TRAILER 0036 00  
UNIT MAINTENANCE**

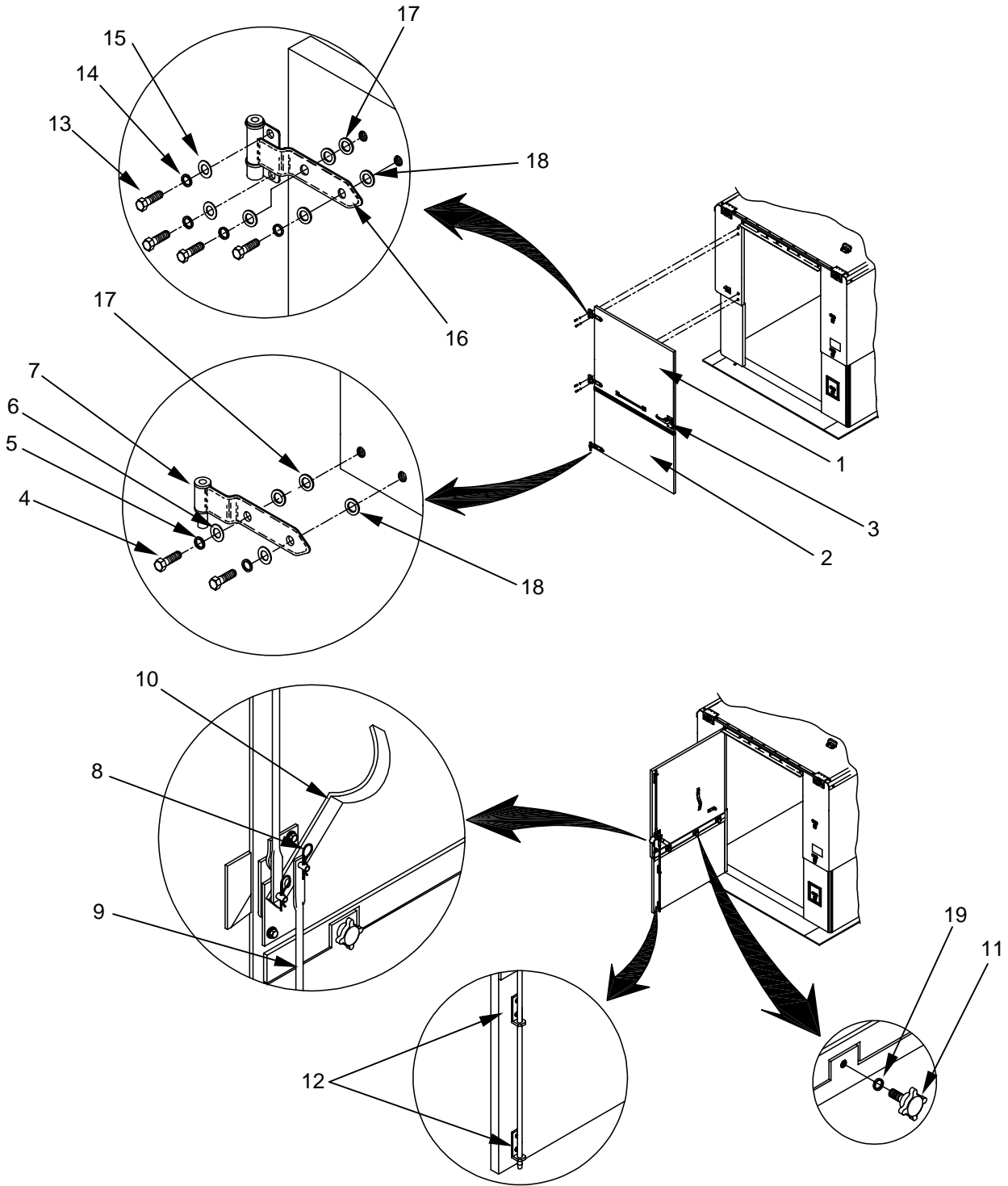

**END OF WORK PACKAGE**



**CARGO BED COVER (CBC), TYPE III, 2 1/2 T CARGO TRUCK, LMTV, AND LMTV TRAILER 0037 00  
UNIT MAINTENANCE**

**MOUNTING PLATE THREADED RIVNUT REPLACEMENT**

**THIS SECTION COVERS:**

Replace

<b>INITIAL SETUP:</b>	<b>Personnel Required:</b> One
<b>Maintenance Level - Unit</b>	<b>Materials/Parts</b>
<b>Tools and Special Tools</b>	Methylethylketone (WP 0055, Table 1, Item 3)
General Mechanic Tool Kit (WP 0041, Table 2, Item 1)	Sandpaper (WP 0055, Table 1, Item 8)
Light, Incandescent Adjustable With Tripod Base (WP 0041, Table 2, Item 2)	Wiping Rags (WP 0055, Table 1, Item 6)
Goggles, Industrial (WP 0041, Table 2, Item 3)	Masking tape (WP 0055, Table 1, Item 5)
Drill, Electric, Portable (WP 0041, Table 2, Item 4)	Alodine, Brush (WP 0055, Table 1, Item 12)
Drill Set, Twist (WP 0041, Table 2, Item 5)	Adhesive, Two Part Epoxy (WP 0055, Table 1, Item 9)
Gloves, Chemical And Oil Protective (WP 0041, Table 2, Item 6)	Cartridges, 1/10 Gallon, Empty (WP 0055, Table 1, Item 10)
Gun, Caulking (WP 0041, Table 2, Item 7)	Nozzle, 2 1/2 in long with 1/8 in orifice (WP 0055, Table 1, Item 11)
Header, Hand-Operated (WP 0041, Table 2, Item 11 OR 13)	Sheet, Aluminum, .032 inch thick X 12 Inches X 12 inches (WP 0055, Table 1, Item 15)
	Sticks, Mixing (WP 0055, Table 1, Item 14)
	Gloves, white, cloth (WP 0055, Table 1, Item 19)
	Light machine oil (WP 0055, Table 1, Item 1)
	Anti-seize Lubricant (WP 0055, Table 1, Item 2)

**REPLACE**



**NOTE**

For RIVNUT's which are not potted, knock out RIVNUT and replace with same type.

Depending on RIVNUT size, select a drill bit in size range listed below:

RIVNUT Thread Size	Drill Size inches (inches)	Install Hole Size (inches)	
		MIN	MAX
10-32	Letter "E" or 1/4 (.250)	.250	.256
1/4-28	Letter "Q" (.332)	.333	.338
5/16-24	Letter "Z" (.413)	.414	.423
3/8-24	12.5 mm (.492)	.491	.500



**WARNING**

Wear safety goggles for eye protection against flying chips.

Using selected drill bit (1), drill head flange (2) from RIVNUT (3). Knock out remaining portion of RIVNUT.

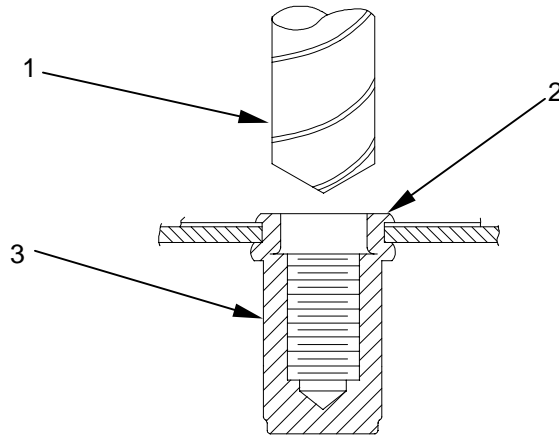

**Installing Threaded RIVNUT's**

**CAUTION**

Always apply anti-seize lubricant to bolt and screw threads before installation to prevent galling.

During the installation of threaded RIVNUT's, the threads inside the threaded RIVNUT can sometimes be damaged by the installation tool, and may result in the bolts and screws binding. If this occurs, run a tap of the RIVNUT thread size through the threaded area. This will clear and straighten the threads, making for easier and faster assembly. Care should be taken using this method since the tap has the ability to remove and/or cross thread existing threads. Be sure to work slowly and deliberately when clearing the threads.

Install the threaded RIVNUT using the appropriate hand operated header (threaded RIVNUT installation tool) (1), hex (allen) wrench (2) (included with installation tool), and 3/4 inch (or 1-1/16 inch depending on header tool used) wrench (9) (adjustable, fixed, or box end ratchet type).



**NOTE**

Before using the installation tool, inspect the condition of the jackscrew threads before use. If the tool has been used previously, the jackscrew threads may require a few drops of a light machine oil. If this is the initial use of the tool, no additional lubrication will be required.

To install a threaded RIVNUT, thread the RIVNUT fastener **(4)** onto the threaded end **(5)** of the installation tool **(1)** included with the mounting kits. Be sure that the end of the installation tool is tight against the head of the fastener.

With the threaded RIVNUT **(4)** installed on the installation tool **(1)**, insert the threaded RIVNUT into the hole **(6)** on the vehicle bed **(7)**.

Insert the hex wrench **(2)** into the socket **(8)** at the top of the installation tool **(1)**. Insert the jaws of a adjustable or fixed wrench **(9)** on the nut **(3)** of the installation tool **(1)**.

While holding the hex wrench **(2)** stationary and the installation tool **(1)** at a right angle to the vehicle bed **(7)**, turn the nut **(3)** in a clockwise direction keeping track of the number of turns.

Turn the nut **(3)** in a clockwise direction until firm resistance indicates that the fastener is completely set. This will be approximately 1-1/2 to 2 turns.

Once the threaded RIVNUT is completely set, turn the nut **(3)** in a counter-clockwise direction to break its grip with the threaded RIVNUT. Remove both wrenches **(2 & 9)** from the installation tool **(1)**.

Remove the threaded insert installation tool **(1)** from the threaded RIVNUT by turning the entire tool by hand in a counter-clockwise direction.

**CARGO BED COVER (CBC), TYPE III, 2 1/2 T CARGO TRUCK, LMTV, AND LMTV TRAILER 0037 00  
UNIT MAINTENANCE**

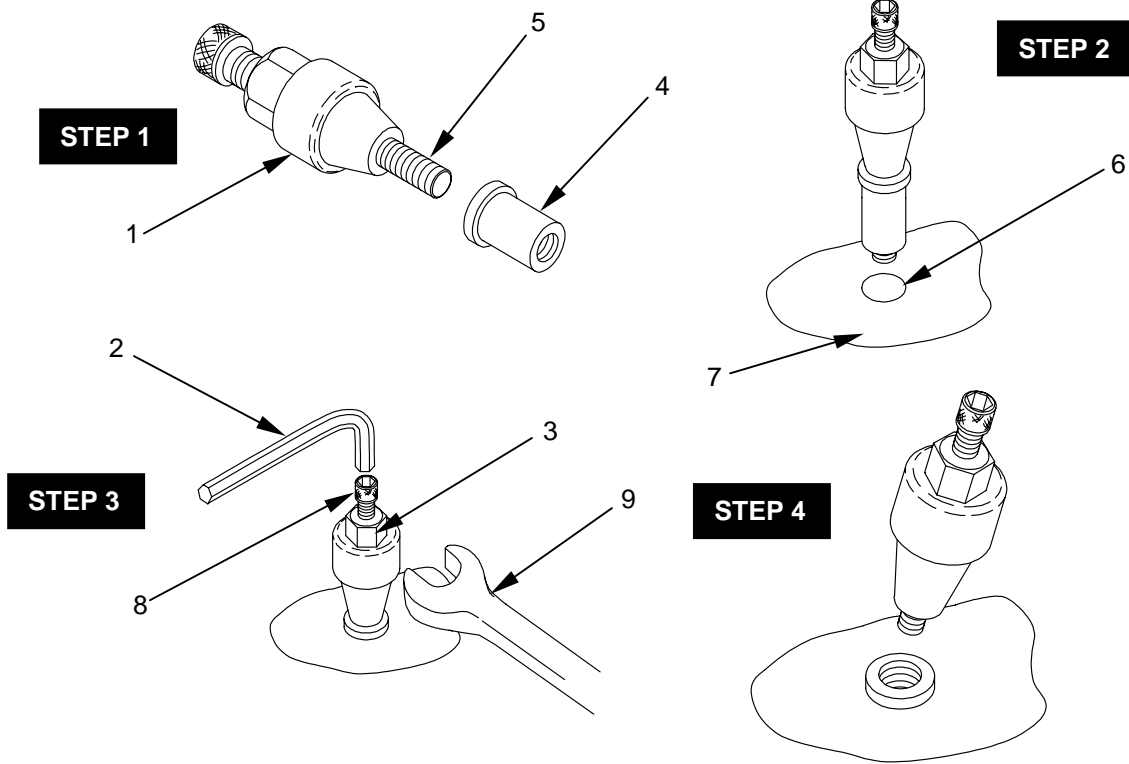

**END OF WORK PACKAGE**



**CARGO BED COVER (CBC), TYPE III, 2 1/2 T CARGO TRUCK, LMTV, AND LMTV TRAILER 0038 00  
UNIT MAINTENANCE**

**WINCH CABLE ASSEMBLIES**

**THIS SECTION COVERS:**

Inspect, Replace

<b>INITIAL SETUP:</b>	<b>Personnel Required:</b> Two
<b>Maintenance Level</b> Unit	<b>Materials/Parts</b> Wood, 2 x 4 Sections, 24 inches in length (WP 0055, Table 1, Item 22)
<b>Tools and Special Tools</b> General Mechanic Tool Kit (WP 0041, Table 2, Item 1)	

**GENERAL**

This procedure contains information and instructions to keep the CBC safe and in good working order by inspecting and replacing the cable assemblies.

**INSPECT**

Inspect the visible portions of the cable assemblies and ensure that there are no surfaces that are abraded, cracked, or otherwise damaged that could prevent the cable assemblies from performing in a safe manner.

**PREPARING THE CBC FOR CABLE REPLACEMENT**

To replace the any of the cable assemblies used to raise and lower the CBC upper section, a hoisting sling must be attached to the CBC in order to support the weight of the upper section during the repair.

Attach the hoisting sling to the CBC lifting rings in accordance with the section of WP 0005 entitled "HOISTING THE CARGO BED COVER USING THE LIFT RINGS". Do not lift the CBC, simply take up the slack in the hoisting sling cables to support the weight of the upper section.

Raising or lowering of the CBC upper section can be accomplished using the CBC winch if a cable assembly is damaged but not broken. If one or more cable assemblies are broken, it will be necessary to use a lifting (hoisting) system to raise and/or lower the CBC upper section in order to install the four equal length supports.

Remove the lower Personnel Door and raise/stow the four lifting/locking assemblies as detailed in the section of WP 0005 entitled "RETRACTING THE CARGO BED COVER".

If one or more cables are broken, use the lifting system to position the CBC upper section to a uniform height of 24 inches as measured from the underside of the roof to the line below the label "DO NOT RAISE ABOVE THIS LINE WITH WINCH" located on the side wall. If one or more cables are not broken, set the ratchet handle to the "LOWER" or "RAISE" position (as required) and raise/lower the upper section of the CBC to the specified height.

**CARGO BED COVER (CBC), TYPE III, 2 1/2 T CARGO TRUCK, LMTV, AND LMTV TRAILER 0038 00  
UNIT MAINTENANCE**

Place four, 24 inch long sections of 2 inch x 4 inch lumber (1) along the side walls near each of the four inside corners (2) of the CBC. The sections must all be the same length. The supports should be placed near each corner but a sufficient distance away from the corner to allow removal of the corner fitting cover plates (3) and pulleys. The 2 x 4 sections are used to support the weight of the upper section of the CBC while the cable assembly is being replaced.

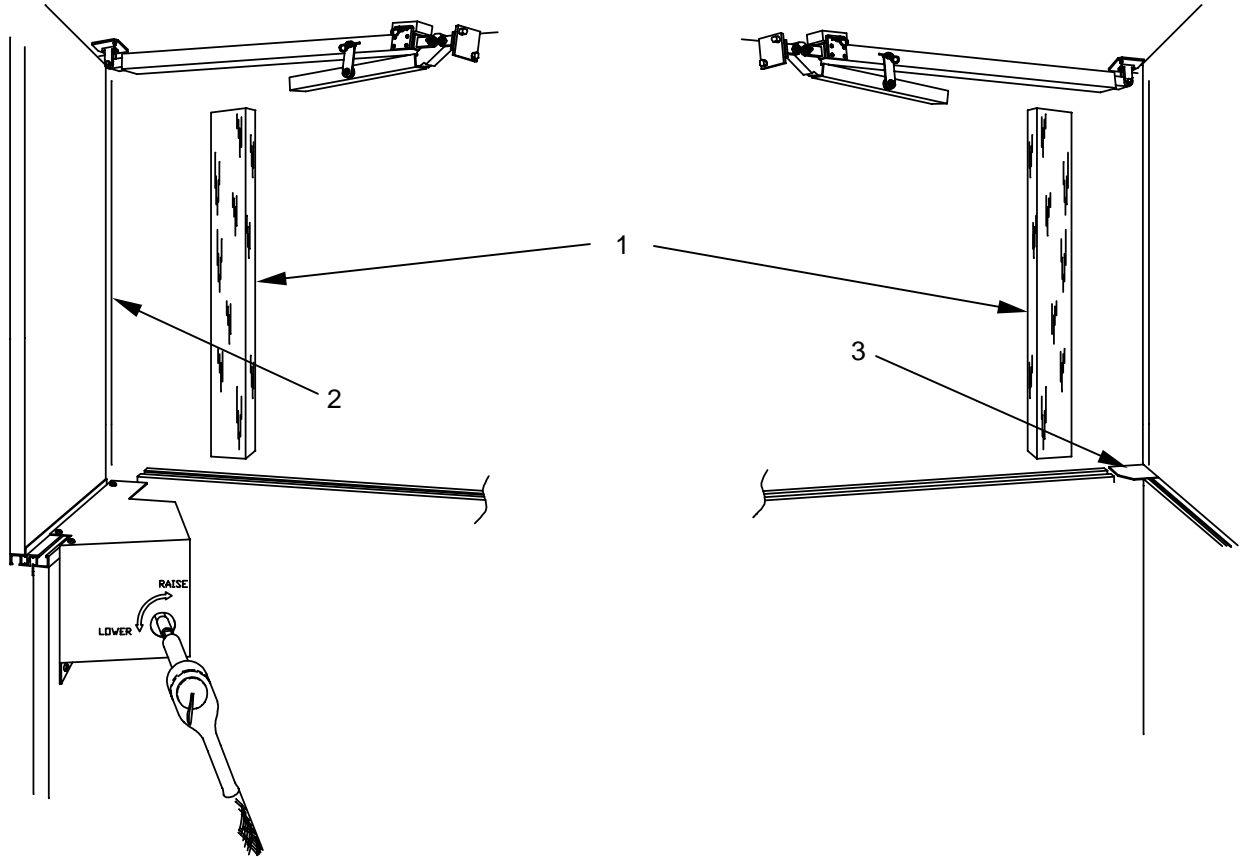

**CARGO BED COVER (CBC), TYPE III, 2 1/2 T CARGO TRUCK, LMTV, AND LMTV TRAILER 0038 00  
UNIT MAINTENANCE**

Remove the winch cover (1) by removing the four screws (2), lockwashers (3), and flat washers (4) that secure the cover. Put the cover and its hardware aside.

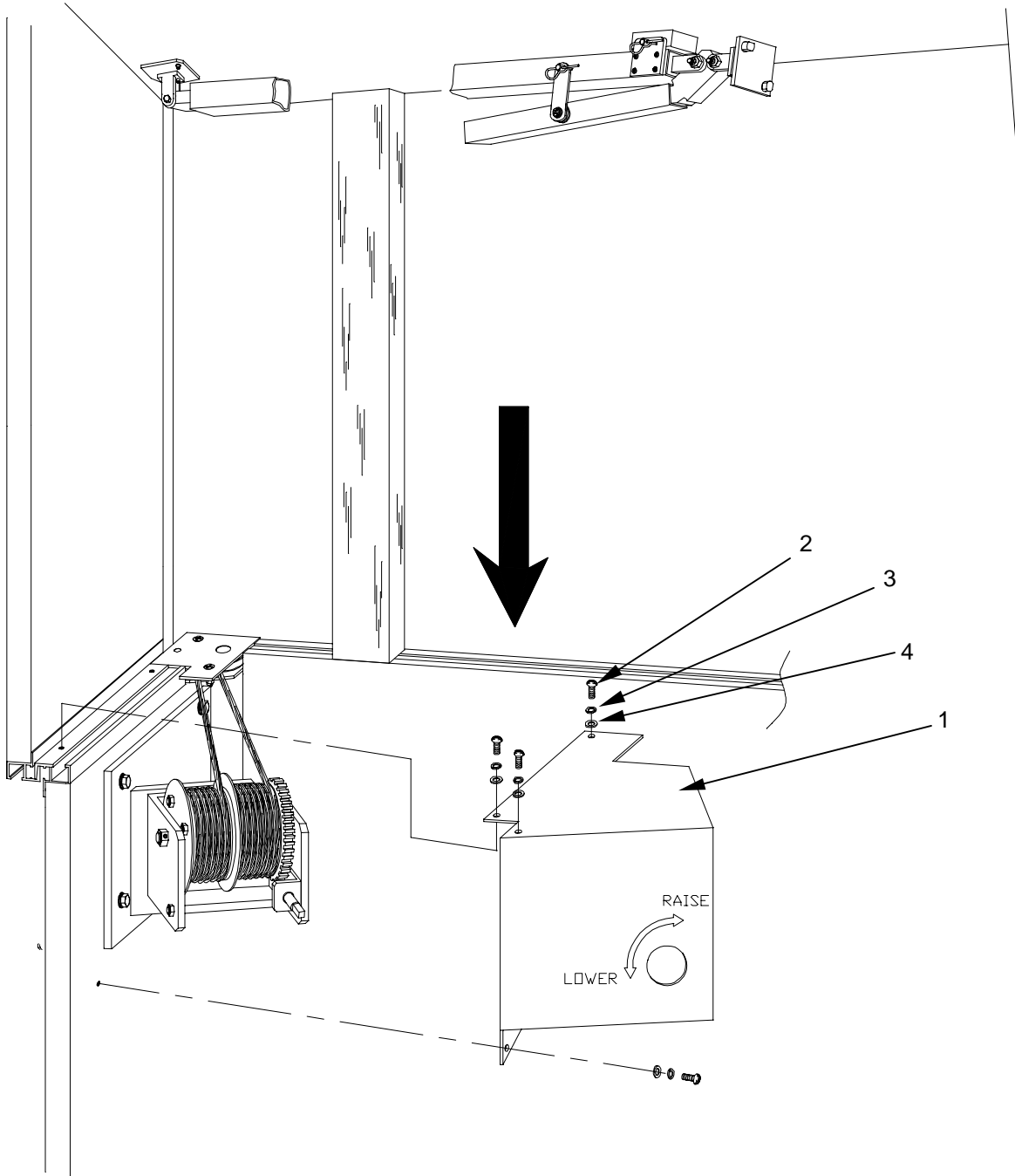

**CARGO BED COVER (CBC), TYPE III, 2 1/2 T CARGO TRUCK, LMTV, AND LMTV TRAILER 0038 00  
UNIT MAINTENANCE**

Using the winch ratchet (1), completely unwind the cables (2) from the winch barrel (3). Use a free hand or another person to guide the cables from the winch barrel to prevent tangling. Once the cables have been unwound, remove each cable assembly end ball (4) from its key-hole slot (5) in the outside plate (6) or middle plate (7). It may be necessary to use force to remove the cable assembly end balls from the key-hole slots.

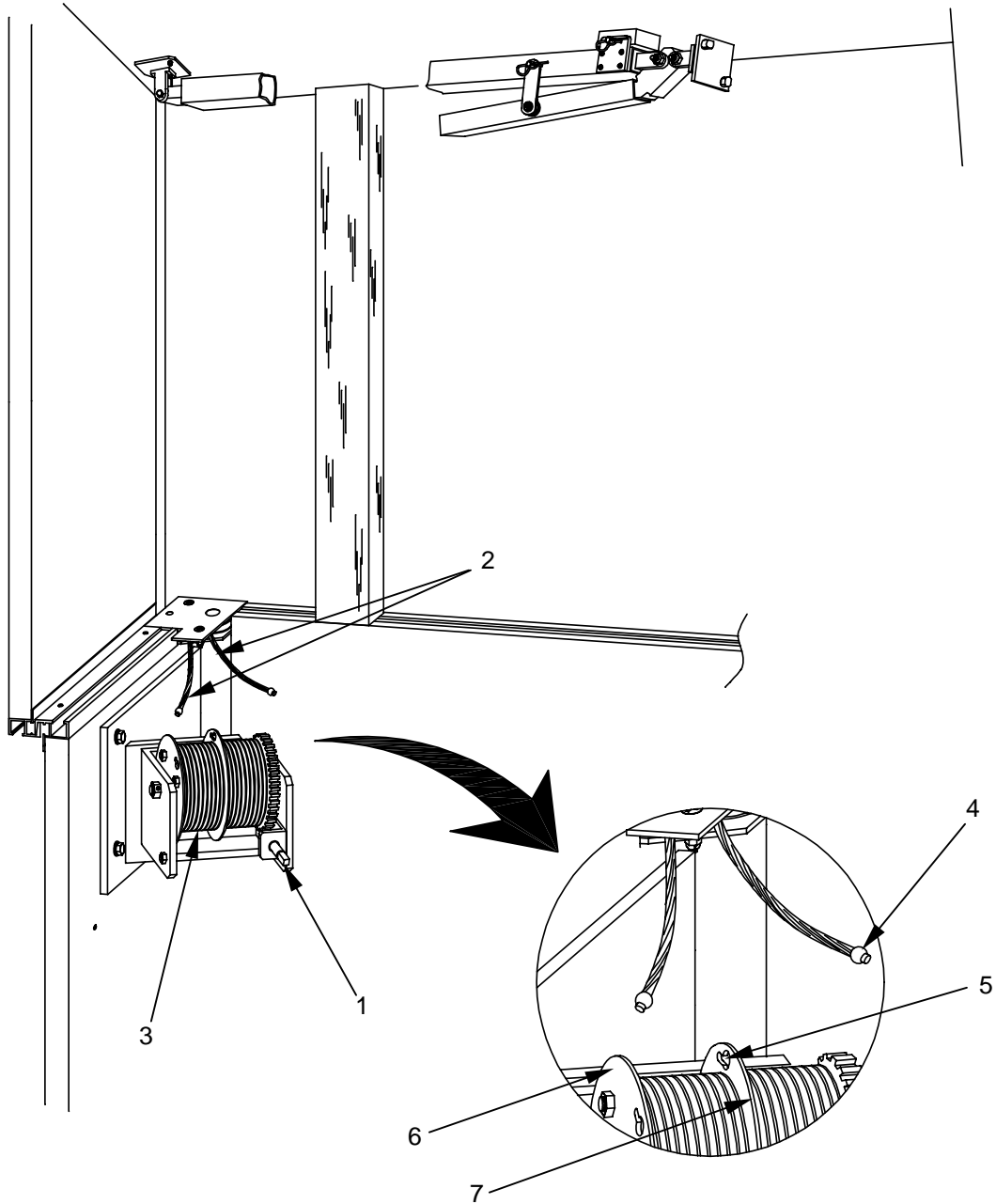

**REPLACING WINCH CORNER CABLE ASSEMBLY**

The following procedure applies only to the replacement of the short cable assembly located at the winch corner. To replace any of the other cable assemblies, refer to the section of this work package entitled "REPLACING CABLE ASSEMBLIES OTHER THAN THE WINCH CORNER".

Once the cables are unwound and completely disconnected from the winch barrel, remove the corner pulley cover plate (1) by removing the two screws (2,6) that secure it in place. Note that the screw (2) closest to the winch has a spacer (3) and is secured with a locknut (4).

Lift and remove the right hand pulley (5) and set it aside.

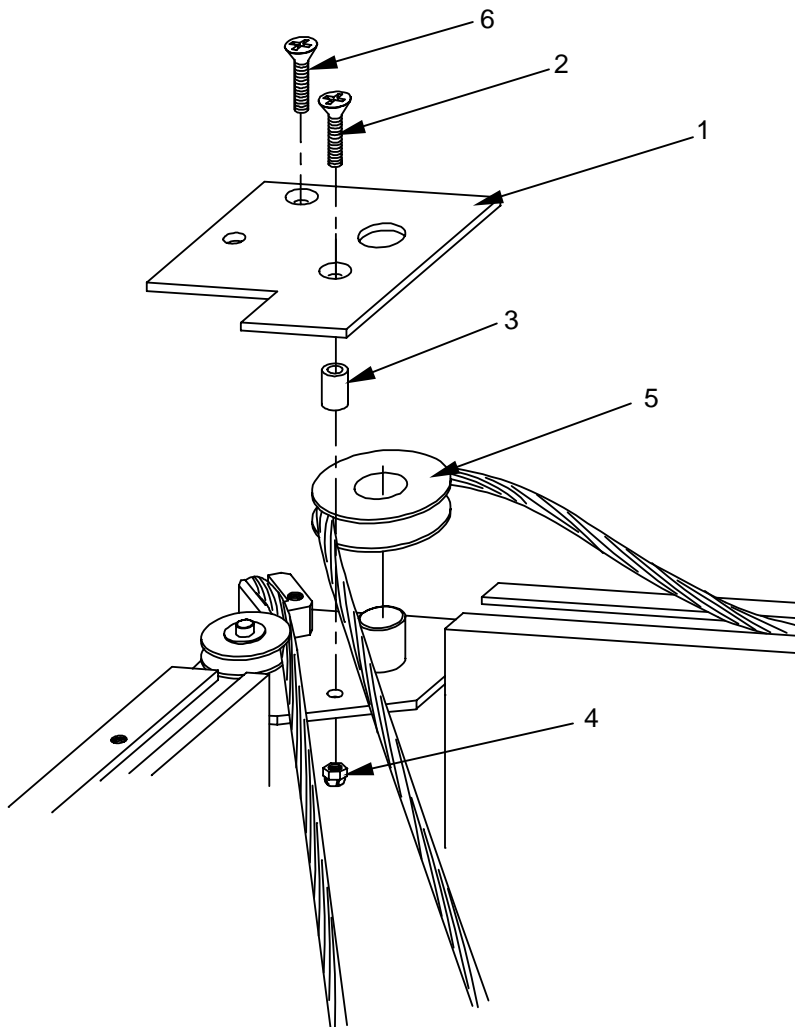

---

**CARGO BED COVER (CBC), TYPE III, 2 1/2 T CARGO TRUCK, LMTV, AND LMTV TRAILER 0038 00  
UNIT MAINTENANCE**

---

Move to the outside of the CBC and remove the corner cable retaining block **(1)** located on the outside of the CBC at the winch corner **(2)** by removing the two screws **(3)** securing it in place. Once the retaining block **(1)** has been removed, loosen and remove the set screw **(4)** at the center of the block **(1)**. Disengage the ball end **(5)** of the cable **(6)** from the retaining block **(1)**.

Position a second person inside the CBC at the winch corner and have them feed the winch corner cable **(6)** over the vertical guide corner pulley **(7)** from the inside of the CBC. It may be necessary to push the ball end of the cable out with a small screwdriver. Pull the winch cable **(6)** through to the outside of the CBC until it is totally removed from the CBC.

Install a new winch corner cable **(6)** by feeding a free end through the inside opening of the CBC at the winch corner. Feed the cable **(6)** through to the outside of the CBC over the vertical guide corner pulley **(7)** to a second person positioned outside the winch corner. Have the second person guide the cable out the CBC.

Once most of the cable has been fed outside the CBC, install the ball end **(5)** of the cable **(6)** into the keyhole **(8)** of the corner cable retaining block **(1)**. Install the set screw **(4)** at the center of the retaining block **(1)**. Tighten securely.

Place the corner cable retaining block **(1)** back into position under the corner **(2)** of the CBC upper section and secure with the two screws **(3)** removed earlier. Tighten securely.

Inside the CBC, pull the winch corner cable assembly **(6)** taut and align the cable in the groove of the left hand pulley **(9)**. Install the right hand pulley **(10)** while aligning the right hand cable **(11)** into the groove of the right hand pulley **(10)**.

Once both pulleys **(9,10)** are in place and the cables **(6,11)** aligned properly, install the corner pulley cover plate **(12)** by installing the two screws **(13)** that secure it in place. Note that the screw closest to the winch has a spacer **(14)** and is secured with a locknut **(15)**.

CARGO BED COVER (CBC), TYPE III, 2 1/2 T CARGO TRUCK, LMTV, AND LMTV TRAILER 0038 00  
UNIT MAINTENANCE

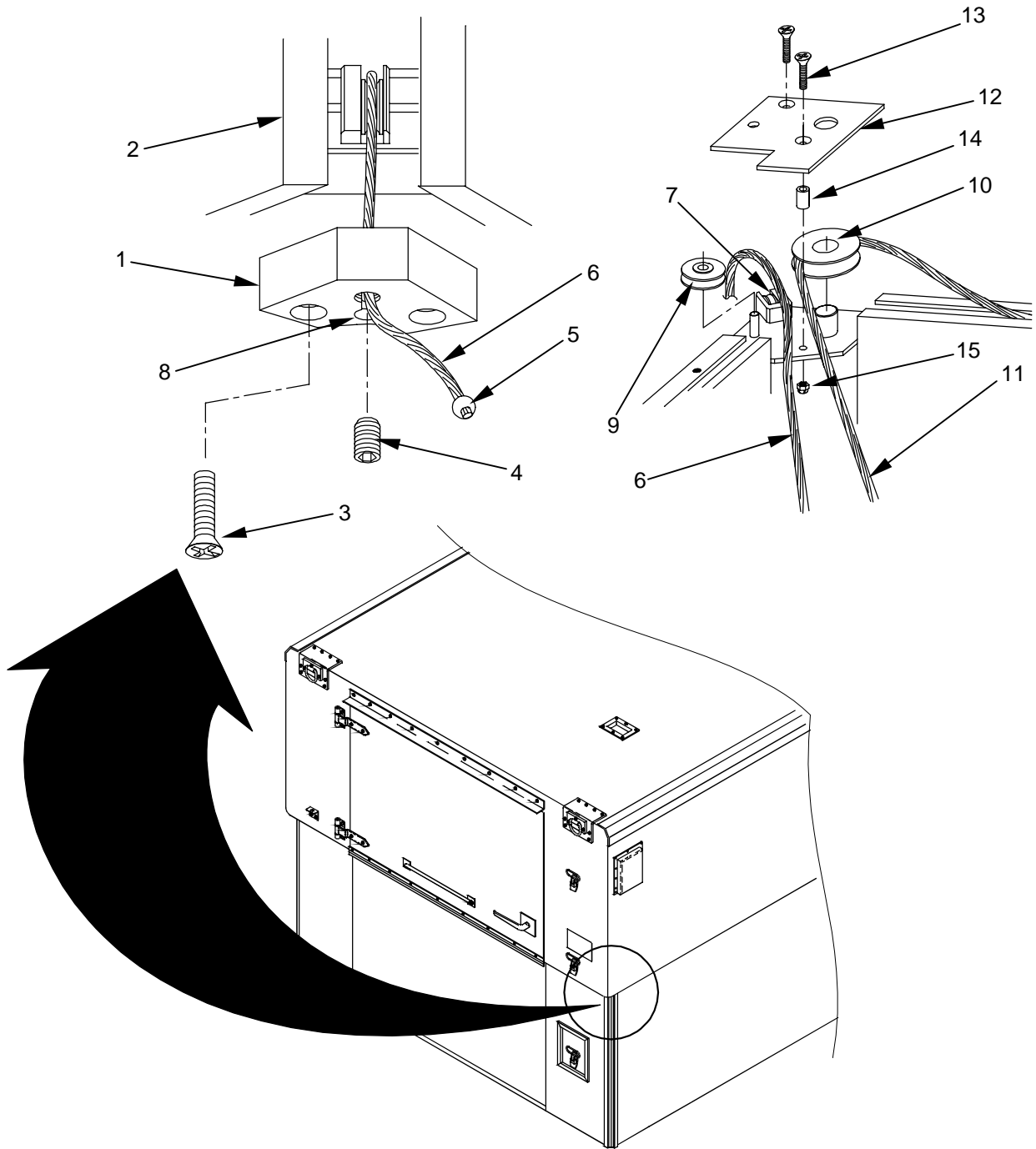

**CARGO BED COVER (CBC), TYPE III, 2 1/2 T CARGO TRUCK, LMTV, AND LMTV TRAILER 0038 00  
UNIT MAINTENANCE**

Rotate the winch barrel (1) to position the keyhole (2) located on the middle plate (3) of the winch barrel (1) at the top of the winch barrel.

Install the ball end (4) of the cable (5) that was NOT replaced, in the keyhole (2) located on the middle plate (3) of the winch barrel (1).

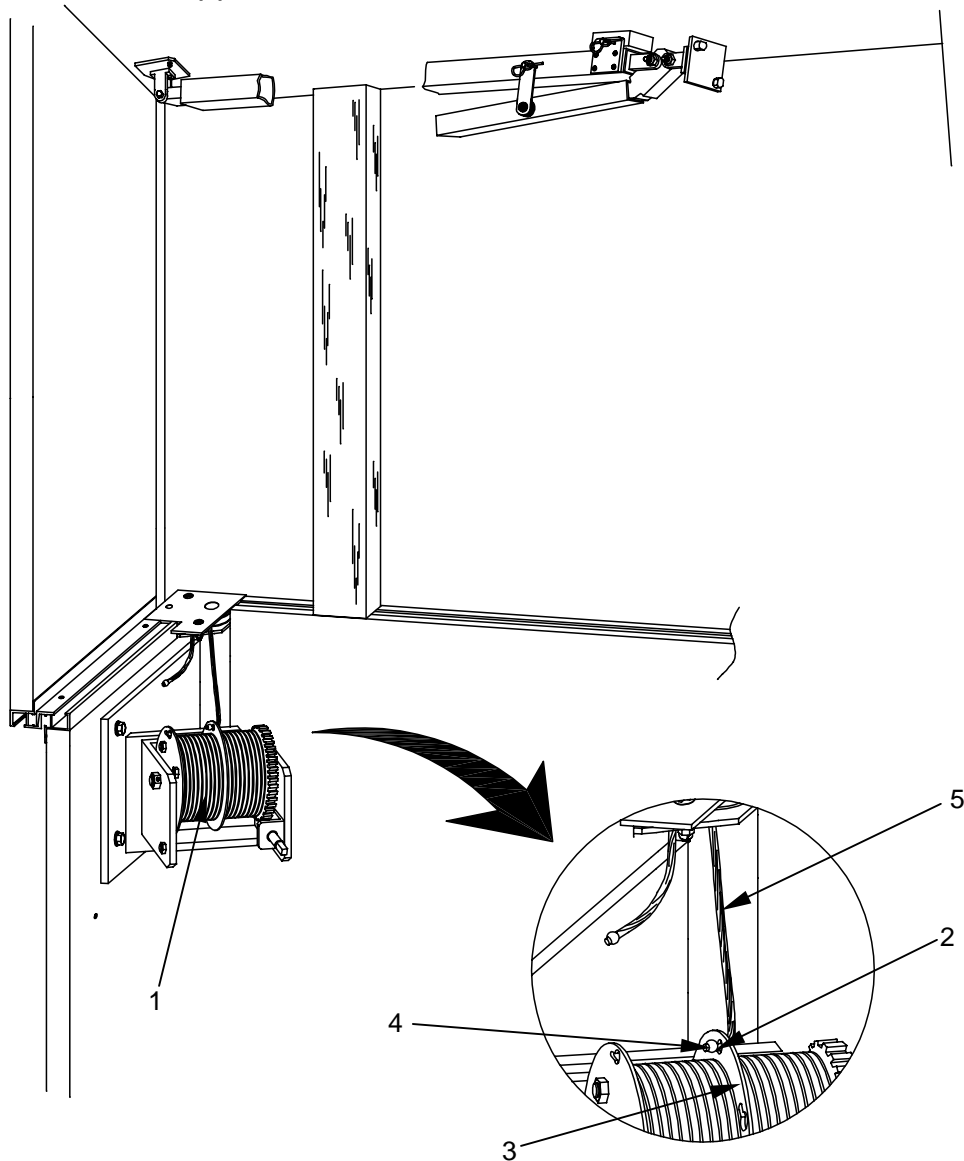



**CARGO BED COVER (CBC), TYPE III, 2 1/2 T CARGO TRUCK, LMTV, AND LMTV TRAILER 0038 00  
UNIT MAINTENANCE**

Slowly rotate the winch barrel (1) approximately 1/2 turn in order to position the keyhole (2) located on the left end plate (3) at the top of the winch barrel.

Install the ball end (4) of the winch corner cable (5) into the keyhole (2) located on the left plate (3) of the winch barrel (1).

Have a second person wearing gloves hold both the winch corner cable (5) and the right hand cable (6) behind the winch in order to guide the cables onto the winch barrel (1). Rotate the ratchet handle (7) and begin taking up the cable onto the winch barrel (1). Ensure that the cable is wound into the grooved recesses (8) on the winch barrel and that the cable remains in a single layer, each turn parallel to the last.

Continue turning the winch barrel until all cable slack is taken up and the cables are taut.

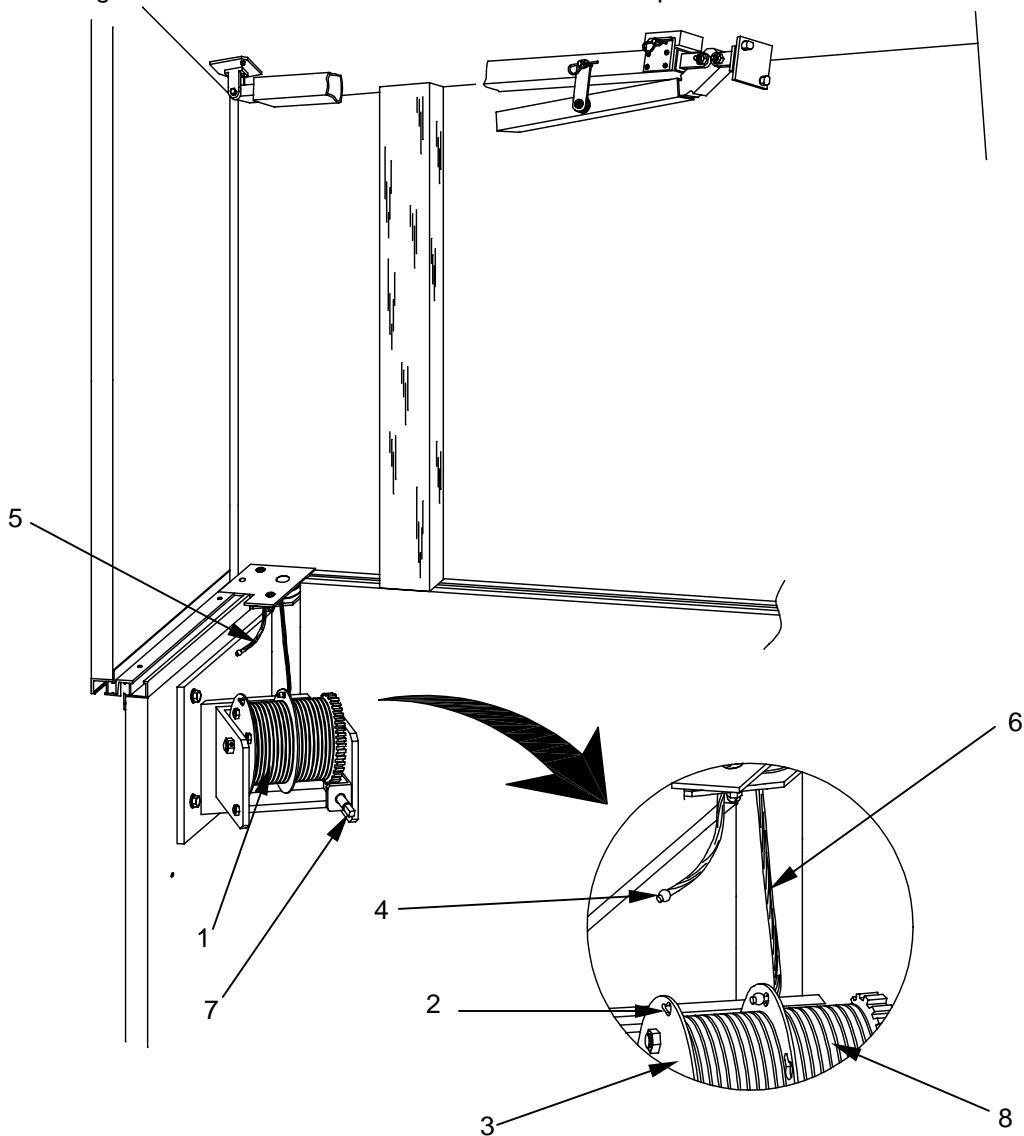

**CARGO BED COVER (CBC), TYPE III, 2 1/2 T CARGO TRUCK, LMTV, AND LMTV TRAILER 0038 00  
UNIT MAINTENANCE**

Check to determine if there is slack in the cable. If slack exists, this will require the adjustment of the three turnbuckle bodies (1) on the long cable assembly (2). If there is slack, raise the CBC upper section (3) with the winch (4) and remove the supports (5).

Measure each corner height from the top edge of the interlock extrusion (6) attached to the top edges of the CBC lower section to the interior roof surface (7) of the CBC upper section. The height of all four corners should be equal within  $\pm 1/8$  inch using the winch corner (8) as a reference point.

Raise and lower the CBC upper section three to five times sending it through approximately 75 percent of its travel each time, checking and if required, adjusting its height at each corner each time, in order to maintain an equal height of all four corners within  $\pm 1/8$  inch. If the dimension varies more than  $\pm 1/8$  inch, then the turnbuckles (1) need to be adjusted as detailed in the section of this work package entitled "REPLACING CABLE ASSEMBLIES OTHER THAN THE WINCH CORNER", by first removing the turnbuckle locking clips, making the turnbuckle body adjustment and reinstalling new turn buckle locking clips after adjustments have been completed.

Install the winch cover (9) by installing the four screws (10), lockwashers (11), and flat washers (12) that secure the cover (9).

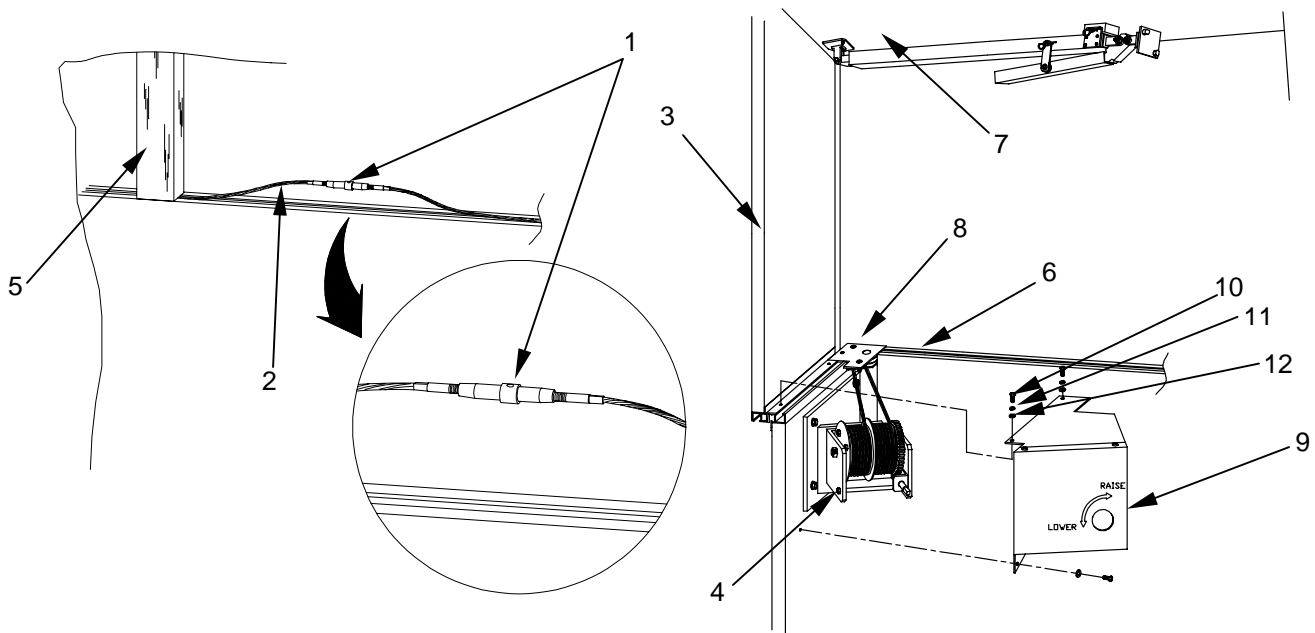

**REPLACING ENTIRE CABLE ASSEMBLY (OTHER THAN THE WINCH CORNER CABLE ASSEMBLY)**

The entire cable assembly (other than the winch corner cable assembly) consists of one long cable **(1)** that extends from the winch to the corner opposite the personnel door from the winch. Three individual cables branch from the long cable **(1)** and extend to each of the three corners (other than the winch corner). Replacement of the entire cable assembly is detailed below; replacement of any of the individual cables is detailed in the section entitled "REPLACING INDIVIDUAL CABLE ASSEMBLIES (OTHER THAN THE WINCH CORNER CABLE ASSEMBLY)"

The procedure that follows applies only to the replacement of a cable assembly **other** than that located at the winch corner. To replace the winch corner cable assembly, refer to the section of this work package entitled "REPLACING WINCH CORNER CABLE ASSEMBLY".

Prepare the CBC for cable replacement as detailed in the previous section entitled "PREPARING THE CBC FOR CABLE REPLACEMENT".

Once the cables are unwound and completely disconnected from the winch barrel, remove the corner pulley cover plates **(2)** located at each corner by removing the two screws **(3,4)** that secure them in place. Note that the front screw **(4)** has a spacer **(5)** and is secured with a locknut **(6)**.

Lift and remove the left **(7)** and right **(8)** hand pulley in each corner and set them aside.

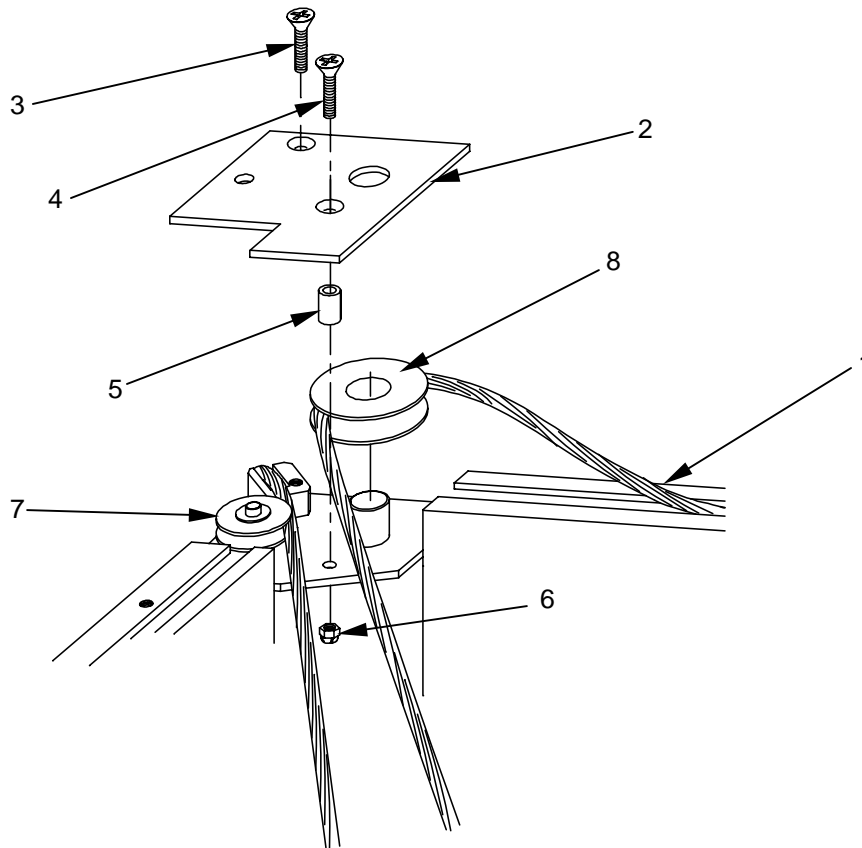

**CARGO BED COVER (CBC), TYPE III, 2 1/2 T CARGO TRUCK, LMTV, AND LMTV TRAILER 0038 00  
UNIT MAINTENANCE**

Move to the outside of the CBC and remove the corner cable retaining blocks **(1)** located on the outside of the CBC at every corner except the winch corner by removing the two screws **(2)** securing it in place. Once the retaining block has been removed, loosen and remove the set screw **(3)** at the center of the block. Disengage the ball end **(4)** of the cable from the retaining block.

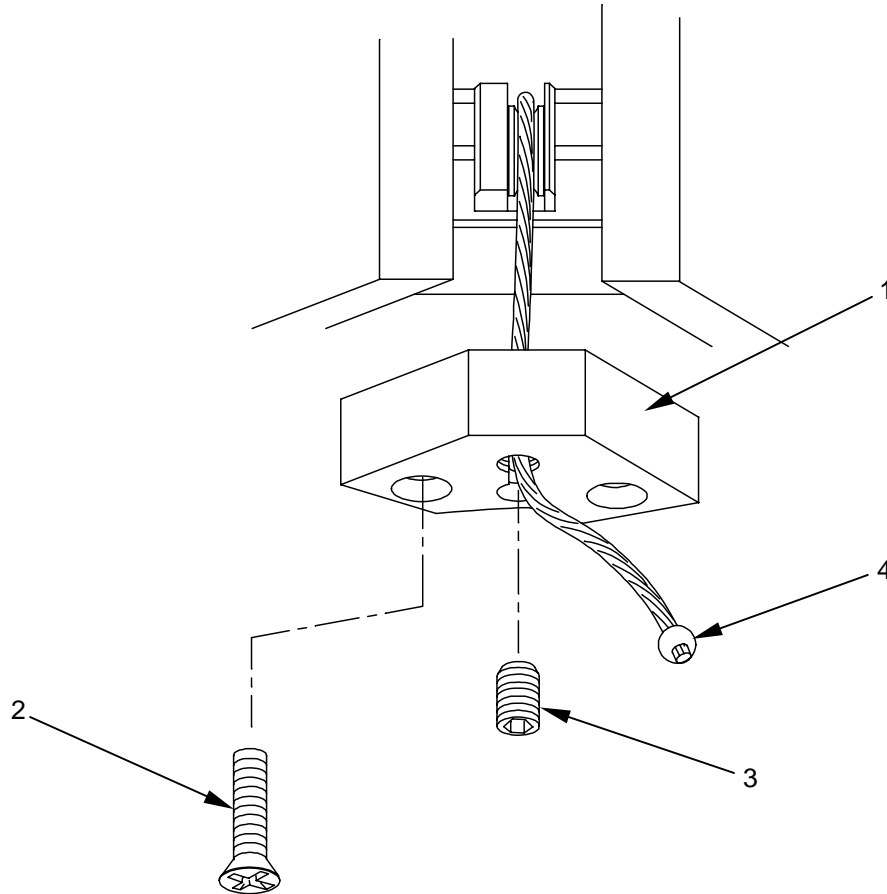

**CARGO BED COVER (CBC), TYPE III, 2 1/2 T CARGO TRUCK, LMTV, AND LMTV TRAILER 0038 00  
UNIT MAINTENANCE**

Locate the turnbuckle (1) in the channel (2) halfway down the sidewall to the right of the winch.

Lift the cable (3) out of the channel (2) to gain access to the turnbuckle (1).

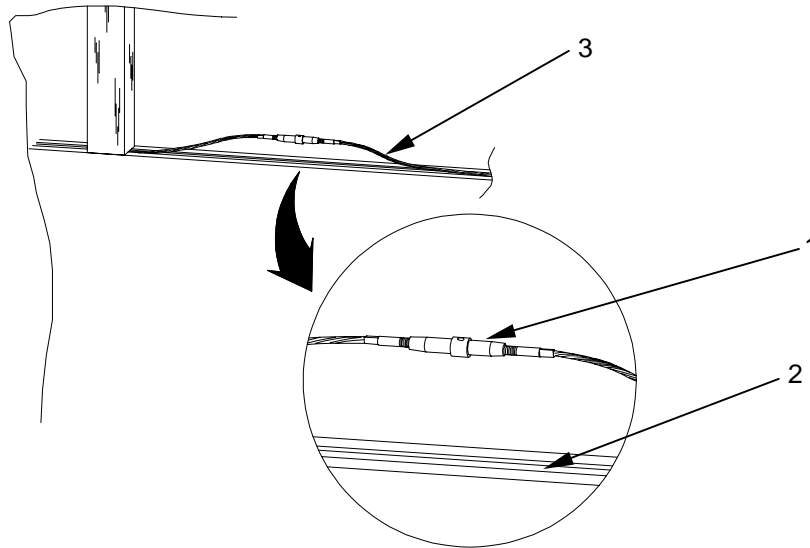

Pull out the end of the left hand turnbuckle locking clip (1) closest to the center hole (2) of the turnbuckle with a pair of needle nose pliers. Slide the locking clip (1) out the left side (3) of the turnbuckle. Repeat for the right hand turnbuckle locking clip (4). Discard removed turnbuckle locking clips as they will be replaced with new ones upon replacing the cable.

Place an open end wrench (5) or similar tool on each of the wire rope end terminals (rod ends) (6) going into the turnbuckle body (7) and unscrew the turnbuckle body using a punch (8) with a tip diameter that fits into the center hole (2). Rotate the turnbuckle body (7) until the threaded portion of the wire rope end terminal (6) is completely removed from the turnbuckle body (7). Set the turnbuckle body (7) aside, it will be required later.

Repeat for remaining two turnbuckles.

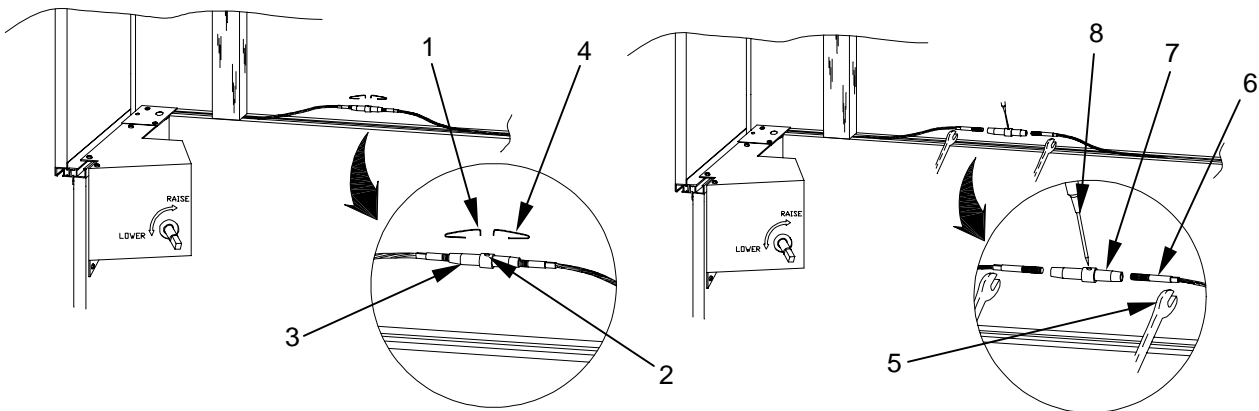

---

**CARGO BED COVER (CBC), TYPE III, 2 1/2 T CARGO TRUCK, LMTV, AND LMTV TRAILER 0038 00  
UNIT MAINTENANCE**

---

Position a second person inside the CBC at one of the corners **(1)** and have them feed each cable **(2)** over the vertical guide corner pulley **(3)** from the inside of the CBC. Pull each cable **(2)** through to the outside of the CBC until it has been removed from the CBC.

Install a new cable **(2)** in each corner **(1)** by feeding a free end through the outside opening of the CBC at the corner. Feed the cable through to the inside of the CBC over the vertical guide corner pulley **(3)** to a second person positioned at that corner. Have the second person guide the cable into the CBC. Repeat for each corner.

Once most of the cable **(2)** has been fed into the CBC, install the ball end **(4)** of the cable outside the CBC into the keyhole **(5)** of each corner cable retaining block **(6)**. Install the set screw **(17)** at the center of the retaining block **(6)**. Tighten securely. Repeat this procedure for each corner.

Place each corner cable retaining block **(6)** back into position under its corresponding corner of the CBC upper section and secure with the two screws **(7)** removed earlier. Tighten securely.

Inside the CBC at each corner, route the cable through the opening **(8)** in the corner and up over the vertical center guide pulley **(3)**. Install the left pulley **(9)** and align the left hand cable (i.e. the short cable that goes down the corner) **(2)** in the groove of the left hand pulley **(9)**. Align the right hand cable (i.e. the long cable with extends to all corners except the winch corner) **(10)** while installing the right hand pulley **(11)**. Be sure that both cables are in their respective pulley grooves **(12)** when both pulleys are installed.

Once both pulleys are in place and the cables are aligned in their respective pulley grooves **(12)**, install the corner pulley cover plate **(13)** by installing the two screws **(14,17)** that secure it in place. Note that the screw **(14)** closest to the inside of the corner has a spacer **(15)** and is secured with a locknut **(16)**.

CARGO BED COVER (CBC), TYPE III, 2 1/2 T CARGO TRUCK, LMTV, AND LMTV TRAILER 0038 00  
UNIT MAINTENANCE

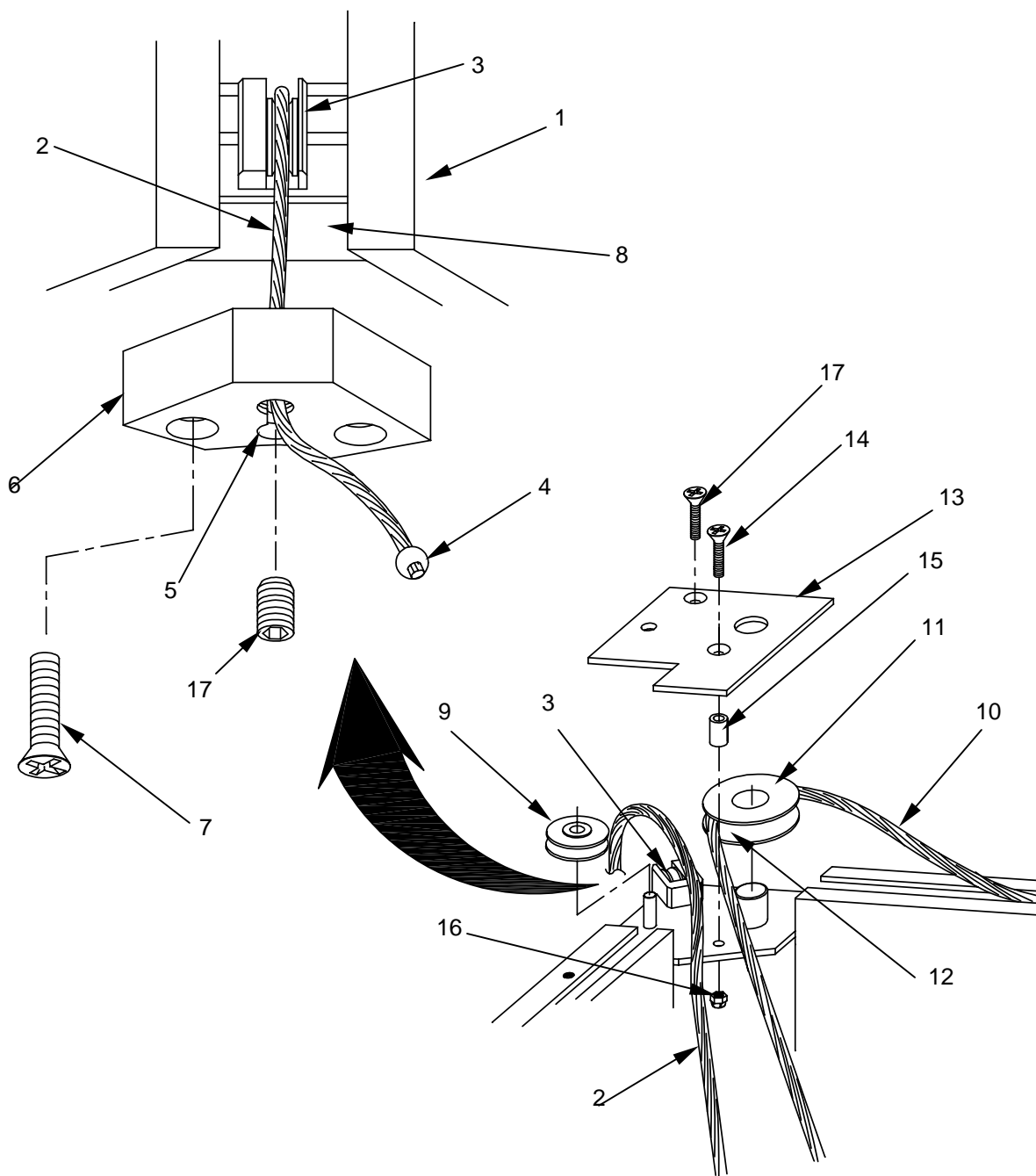

**CARGO BED COVER (CBC), TYPE III, 2 1/2 T CARGO TRUCK, LMTV, AND LMTV TRAILER 0038 00  
UNIT MAINTENANCE**

Lay the cables (1) in the channels (2) on the inside of the CBC, keeping the threaded ends (3) accessible.

Install the threaded end (3) of each terminal (rod end), one on the long cable and one on the short cable going down each corner (other than the winch corner) into the turnbuckle body (4) removed earlier. Screw the terminal ends (3) into the turnbuckle body (4) an equal amount until approximately 1/8 inch of thread are still exposed. Repeat for each of the three turnbuckle bodies.

When screwing the terminal ends (3) into the turnbuckle body (4), be sure that the line (5) on the shaft of the terminal end (3) is lined up EXACTLY with the small angled cutout (6) located on the edge of the turnbuckle body (4). If the line (5) is not lined up exactly with the cutout (6), the locking pins (7) installed in a later step will not install in the turnbuckle body.

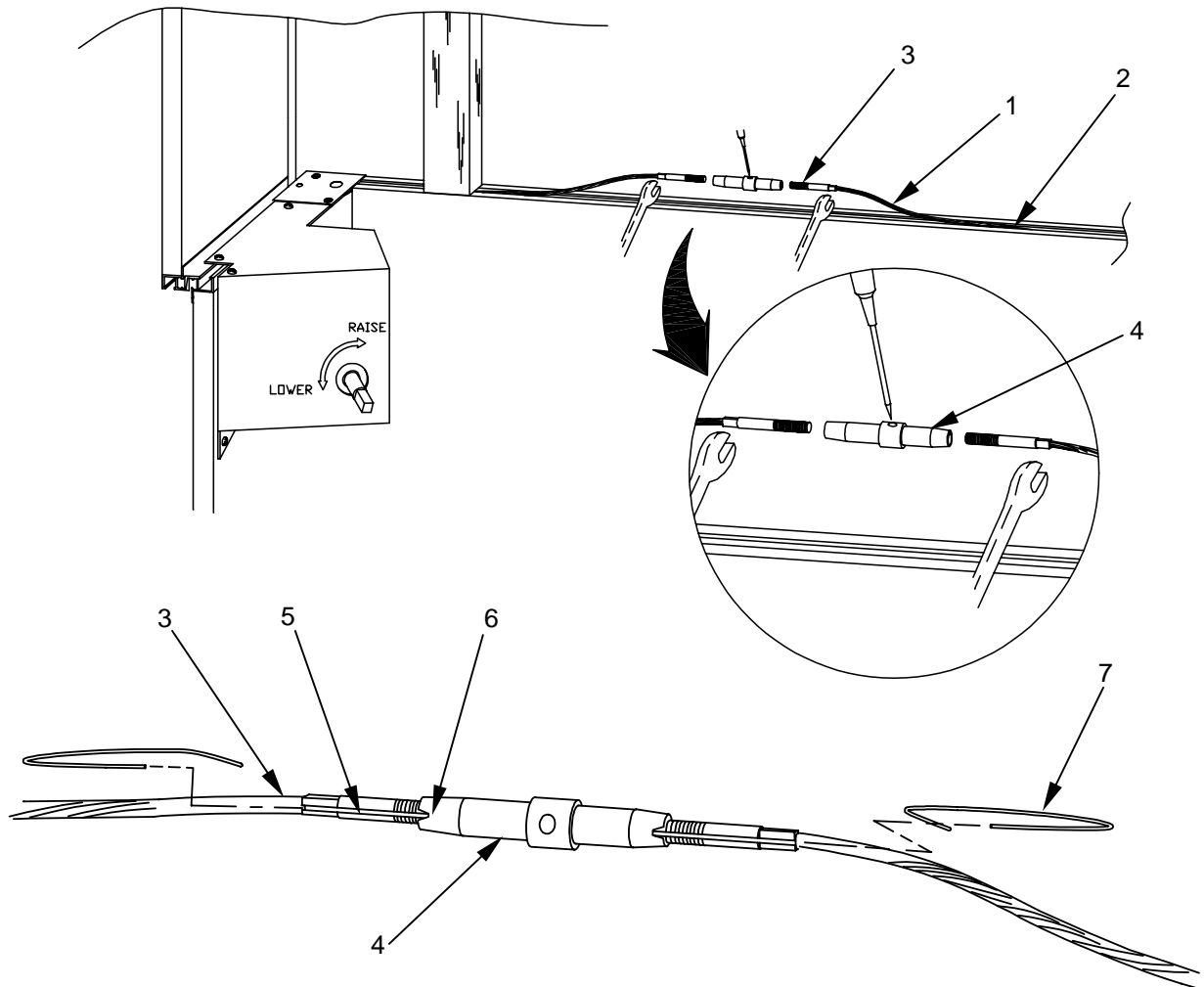



**CARGO BED COVER (CBC), TYPE III, 2 1/2 T CARGO TRUCK, LMTV, AND LMTV TRAILER 0038 00  
UNIT MAINTENANCE**

Once all turnbuckles are installed and all cables are in their respective channels, rotate the winch barrel (1) as necessary to position the keyhole (2) located on the middle plate (3) of the winch barrel at the top.

Install the ball end (4) of the cable (5) nearest the right side of the winch (not the winch corner cable assembly) in the keyhole (2) located on the middle plate (3) of the winch barrel (1).

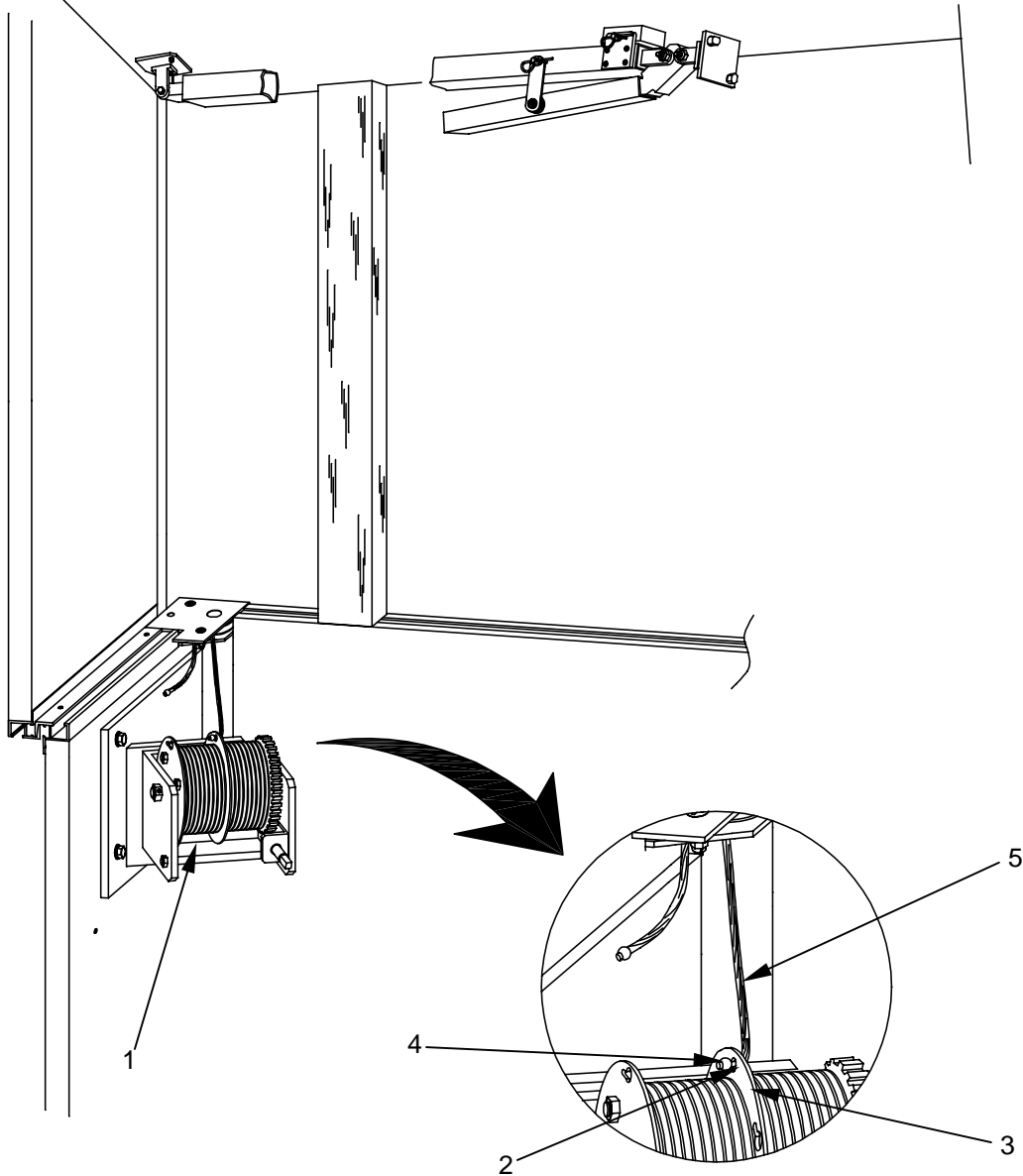

**CARGO BED COVER (CBC), TYPE III, 2 1/2 T CARGO TRUCK, LMTV, AND LMTV TRAILER 0038 00  
UNIT MAINTENANCE**

Slowly rotate the winch barrel (1) approximately 1/2 turn in order to position the keyhole (2) located on the left end plate (3) of the winch barrel (1) at the top.

Install the ball end (4) of the winch corner cable (5) into the keyhole (2) located on the left end plate (3) of the winch barrel (1).

Have a person wearing gloves hold both the winch corner cable (5) and the right hand cable (6) behind the winch in order to guide the cables onto the winch barrel (1). Rotate the ratchet handle (7) and begin taking up the cable onto the winch barrel (1). Ensure that the cable is wound into the grooved recesses (8) on the winch barrel (1) and that the cable remains in a single layer, each turn parallel to the one before.

Continue turning the winch barrel (1) until all cable slack is taken up and the cables are taut.

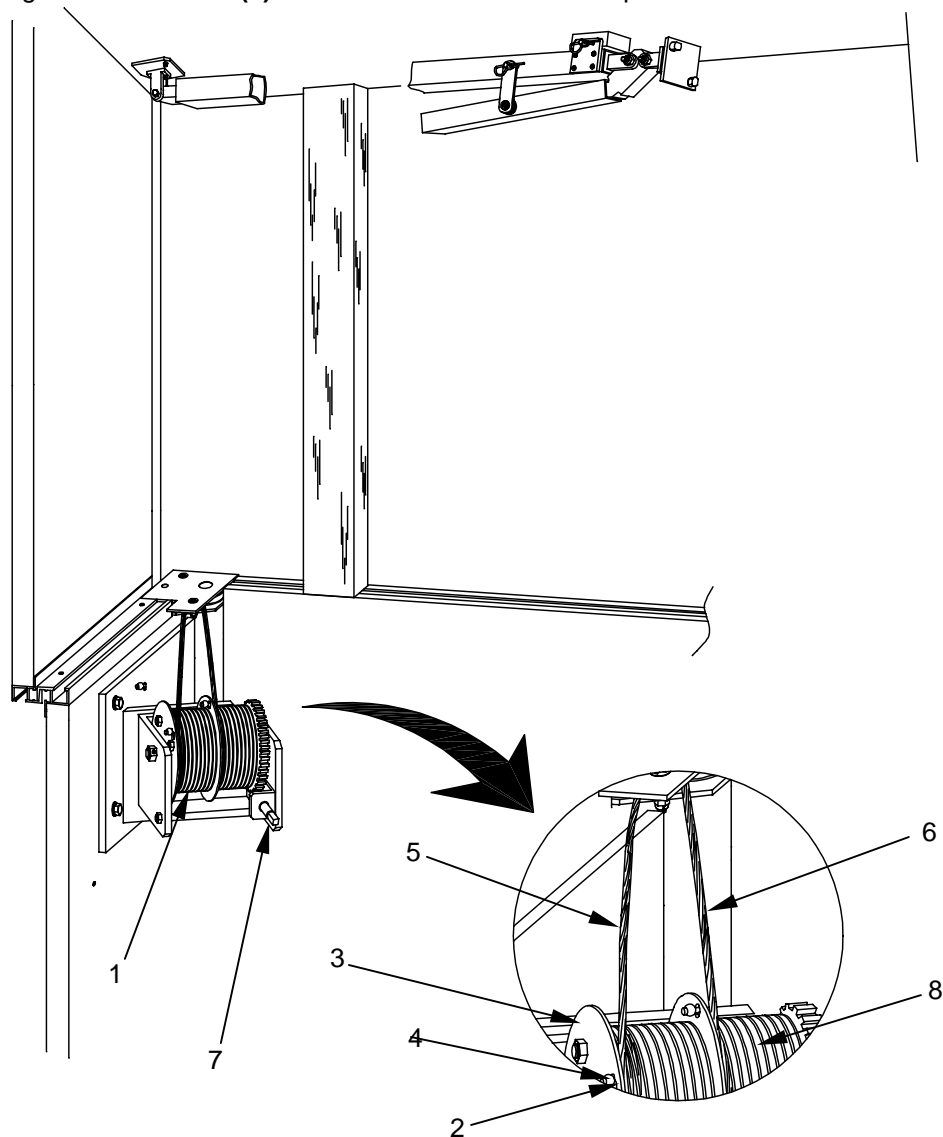

**CARGO BED COVER (CBC), TYPE III, 2 1/2 T CARGO TRUCK, LMTV, AND LMTV TRAILER 0038 00 UNIT MAINTENANCE**

Adjust the three turnbuckle bodies (1) until their respective CBC corner begins to rise, remove the support (2) and measure each corner height from the top edge of the cable channel (3) that runs along the top edge of the CBC lower section, to the interior roof surface of the CBC upper section. The height of all four corners should be within +/- 1/8 inch using the winch corner (4) as a reference point. If the corners are not equal, adjust the three turnbuckle bodies (1) until their respective corner is equal to the winch corner height to within +/- 1/8 inch. Raise and lower the CBC upper section three to five times through approximately 75 percent of its travel, checking and adjusting the height at each corner each time as required to ensure that the height at each corner is to within +/- 1/8 inch.

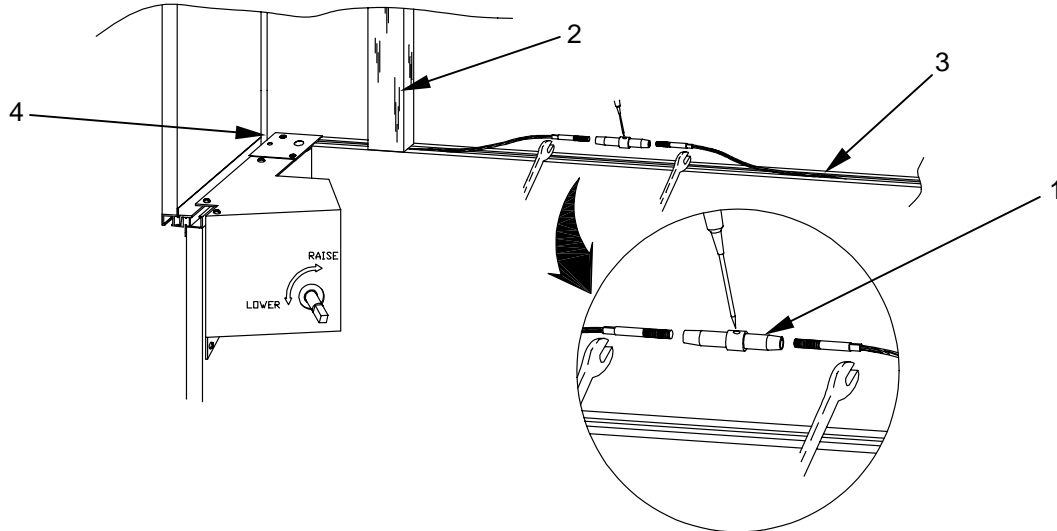

Once all turnbuckles (1) have been adjusted, new turnbuckle locking clips (2) must be installed in the turnbuckles (1). Using a pair of needle nose pliers slide the long end (straight portion) (3) of a new turnbuckle locking clip (2) into the left end (4) of the turnbuckle body (1) positioned closest to the winch corner. Install the bent end (5) of the turnbuckle locking clip (2) into the center hole (6) of the turnbuckle body (1). Repeat for the right turnbuckle locking clip (7). Repeat turnbuckle locking clip installation procedure for each turnbuckle body.

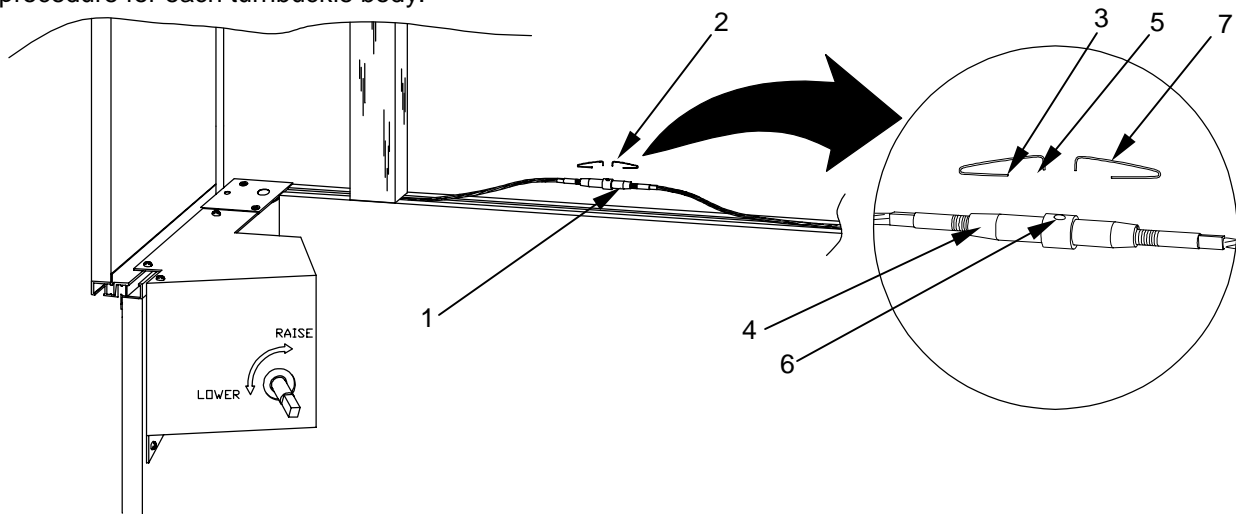

**CARGO BED COVER (CBC), TYPE III, 2 1/2 T CARGO TRUCK, LMTV, AND LMTV TRAILER 0038 00  
UNIT MAINTENANCE**

Install the winch cover (1) by installing the four screws (2), lockwashers (3), and flat washers (4) that secure the cover (1).

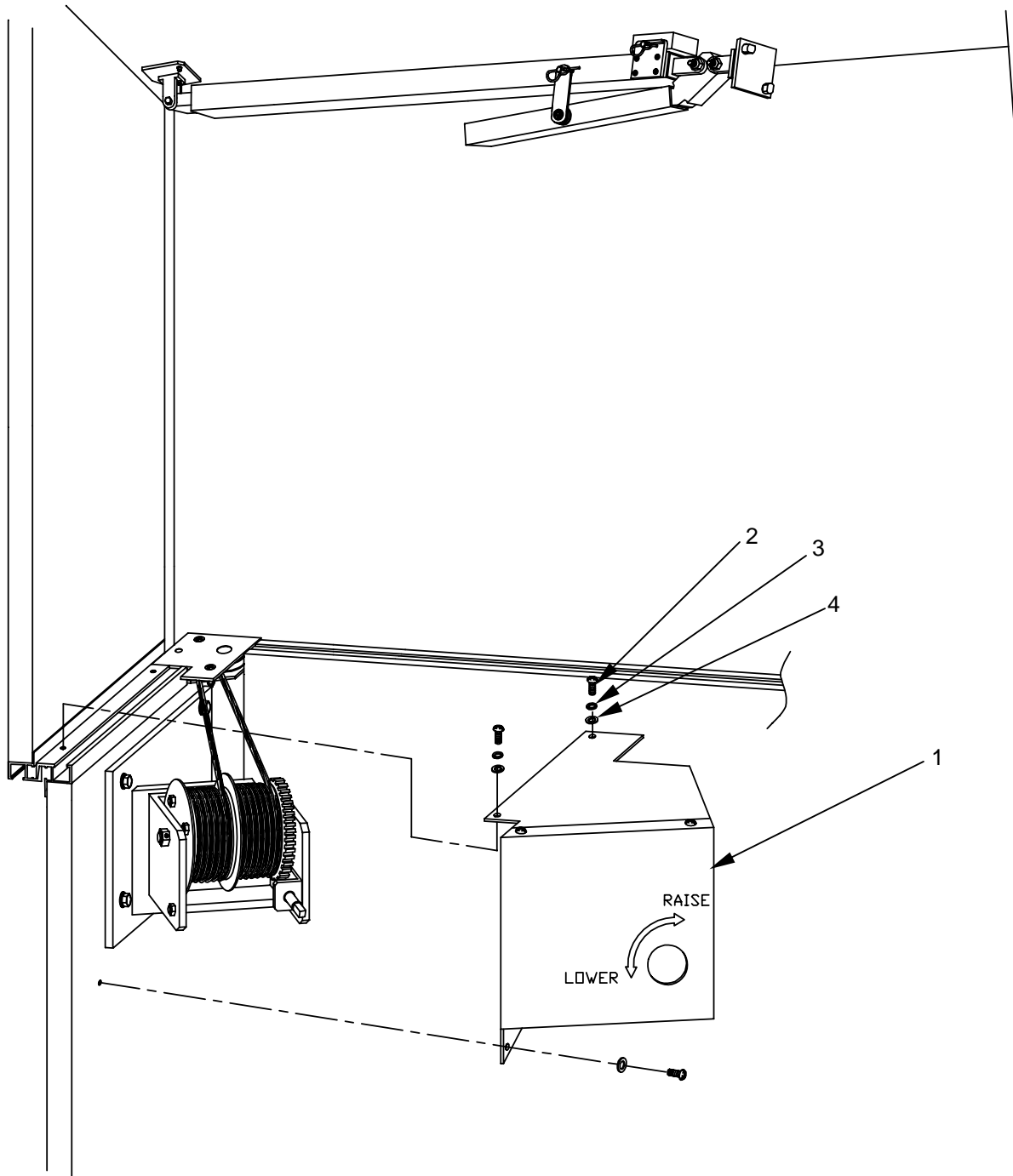

**REPLACING INDIVIDUAL CABLE ASSEMBLIES  
(OTHER THAN THE WINCH CORNER CABLE ASSEMBLY)**

The entire cable assembly (other than the winch corner cable assembly) consists of one long cable that extends from the winch to the corner opposite the personnel door from the winch. Three individual cables branch from the long cable and extend to each of the three corners (other than the winch corner). The replacement of any of the four individual cable assemblies is detailed below; replacement of the entire cable assembly is detailed in the previous section entitled "REPLACING ENTIRE CABLE ASSEMBLY (OTHER THAN THE WINCH CORNER CABLE ASSEMBLY)".



**NOTE**

Many of the procedures for replacing an individual cable assembly are the same as those detailed in the previous section entitled "REPLACING ENTIRE CABLE ASSEMBLY (OTHER THAN THE WINCH CORNER CABLE ASSEMBLY)", therefore references will simply be made to the previous section as appropriate.

The procedure that follows applies only to the replacement of a cable assembly other than that located at the winch corner. To replace the winch corner cable assembly, refer to the section of this work package entitled "REPLACING WINCH CORNER CABLE ASSEMBLY".

Each of the four cables making up the cable assembly other than the winch corner cable assembly may be replaced individually up to all four in quantity. Replacement of one individual cable assembly of the four would be handled in the same manner as for all four, specifically the long cable assembly which goes to each of the three corners other than the winch corner. Replacement of one of the cable assemblies which goes from the long cable assembly to an individual corner is as follows.

Prepare the CBC for cable replacement as detailed in the previous section entitled "PREPARING THE CBC FOR CABLE REPLACEMENT".

Remove the cable assemblies from the winch barrel as detailed in the previous section.

Remove the pulley corner bracket top plate, from the corner where the damaged cable assembly is located. If it is the long cable being replaced, then all pulley corner bracket top plates must be removed. Proceed with removal of pulley corner top plate as detailed in the previous section.

Remove the turnbuckle locking clips from the cable being replaced and from all three turnbuckles, if long cable assembly is being replaced as detailed in the previous section.

Remove the turnbuckle body, disconnecting the damaged cable from the long cable. If replacing the long cable assembly, disconnect all three short cable assemblies that go down each corner (other than the winch corner) at the point where they connect to the long cable.

---

**CARGO BED COVER (CBC), TYPE III, 2 1/2 T CARGO TRUCK, LMTV, AND LMTV TRAILER 0038 00  
UNIT MAINTENANCE**

---

Install a new cable assembly as detailed in the previous section by connecting the replacement cable assembly to the long cable assembly using the turnbuckle body or if the long cable assembly is being replaced, the three turnbuckle bodies connecting it to the three short cable assemblies at the three corners (other than the winch corner).

Connect the two cable assemblies to the winch barrel, as detailed in the previous section, wrapping them until they are taut.

Raise and lower the upper section three to five times, adjusting the turnbuckle bodies each time as detailed in the previous section.

Install all turnbuckle locking clips as detailed in the previous section.

**END OF WORK PACKAGE**

**TM 10-5411-233-13&P**

**CARGO BED COVER (CBC), TYPE III, 2 1/2 T CARGO TRUCK, LMTV, AND LMTV TRAILER 0039 00  
UNIT MAINTENANCE**

**PAINT AND REFINISHING**

**THIS SECTION COVERS:**

Repair

**INITIAL SETUP**

**Maintenance Level**

**Materials/Parts**

Unit

**Tools and Special Tools**

General Mechanic Tool Kit (WP 0041, Table 2, Item 1)

**REPAIR**

Table 1. Paint Data for Cargo Bed Covers

<b>Use</b>	<b>Type</b>	<b>Specification Color</b>	<b>Color Code per FED-STD-595</b>
Interior	Coating, Epoxy	MIL-PRF-22750	27875
Interior (Personnel Door)	Coating, Aliphatic Polyurethane	MIL-C-46168 or MIL-C-53039 Green 383	34094
Exterior	Coating, Aliphatic Polyurethane	MIL-C-46168 or MIL-C-53039 Green 383	34094
Exterior	Coating, Aliphatic Polyurethane	MIL-C-46168 or MIL-C-53039 Brown 383	30051
Exterior	Coating, Aliphatic Polyurethane	MIL-C-46168 or MIL-C-53039 Black	37030
Exterior	Coating, Aliphatic Polyurethane	MIL-C-46168 or MIL-C-53039 Sand	33303
Exterior	Coating, Aliphatic Polyurethane	MIL-C-46168 or MIL-C-53039 Tan	33446
Primer	Primer, Epoxy Coating	MIL-P-23377, Type I, Class C or N or MIL-P-53022, Type I or II	

Prepare surface for painting by removing all corrosion by wire brushing, sanding, or application of corrosion-removing compounds.

Chemically treat all aluminum parts in accordance with MIL-C-5541, Class 1A.

Areas to be painted shall be free of dust, residue, and cleaning compounds before refinishing.

Solvent, primer or paint shall not be applied to seals or non-metal parts. Mask such parts with masking tape for protection.

**TM 10-5411-233-13&P**

---

**CARGO BED COVER (CBC), TYPE III, 2 1/2 T CARGO TRUCK, LMTV, AND LMTV TRAILER 0039 00  
UNIT MAINTENANCE**

---

Mix and apply epoxy polyamide primer coating in accordance with manufacturer's instructions.  
Allow to dry thoroughly before applying finish coat.

Mix and apply paint in accordance with manufacturer's instructions.

Apply two separate, uniform coats, allowing the first coat to dry before applying the second coat. Make sure there are no sags or runs.

**END OF WORK PACKAGE**



**TM 10-5411-233-13&P**

**CHAPTER 6**

**SUPPORTING INFORMATION  
FOR  
CARGO BED COVER (CBC), TYPE III,  
2 1/2 T CARGO TRUCK, LMTV, AND LMTV TRAILER**



---

**CARGO BED COVER (CBC), TYPE III, 2 1/2 T CARGO TRUCK, LMTV, AND LMTV TRAILER 0040 00**  
**REFERENCES**

---

**SCOPE**

This section lists all field manuals, forms, technical manuals and miscellaneous publications referenced in this manual.

**PAMPHLETS**

Functional User's Manual for the  
Army Maintenance Management System (TAMMS) ..... DA Pam 738-750

**FIELD MANUALS**

Basic Cold Weather Manual ..... FM 31-70  
First Aid for Soldiers ..... FM 21-11  
Decontamination Procedures ..... FM 3-5  
Mountain Operations ..... FM 3-97.6  
Northern Operations ..... FM 31-71  
Recovery and Battlefield Damage Assessment and Repair ..... FM 9-43-2  
Packing of Materiel for Packing ..... FM 38-701

**FORMS**

Discrepancy in Shipment Report ..... SF 361  
Equipment Control Record ..... DA Form 2408-9  
Equipment Inspection and Maintenance Worksheet ..... DA Form 2404  
Product Quality Deficiency Report ..... SF 368  
Recommended Changes to Equipment Technical Publications ..... DA Form 2028-2  
Report of Discrepancy ..... SF 364  
Report of Packaging and Handling Deficiencies..... SF 362

**TECHNICAL MANUALS**

Procedures for Destruction of Army Equipment to  
Prevent Enemy Use (Mobility Equipment Command) ..... TM 750-244-3

**MISCELLANEOUS PUBLICATIONS**

Army Medical Department Expendable/Durable Items ..... CTA 8-100  
Expendable/Durable Items ..... CTA 50-970



---

**CARGO BED COVER (CBC), TYPE III, 2 1/2 T CARGO TRUCK, LMTV, AND LMTV TRAILER 0041 00  
MAINTENANCE ALLOCATION CHART (MAC)**

---

**INTRODUCTION****The Army Maintenance System MAC**

This introduction provides a general explanation of all maintenance and repair functions authorized at the two maintenance levels under the Two-Level Maintenance System concept.

This MAC (immediately following the introduction) designates overall authority and responsibility for the performance of maintenance functions on the identified end item or component. The application of the maintenance functions to the end item or component shall be consistent with the capacities and capabilities of the designated maintenance levels, which are shown on the MAC in column (4) as:

Field - includes two columns, Unit maintenance and Direct Support maintenance. The Unit maintenance column is divided again into two more subcolumns, C for Operator or Crew and O for Unit Maintenance.

Sustainment – includes two subcolumns, General Support (H) and Depot (D).

The tools and test equipment requirements (immediately following the MAC) list the tools and test equipment (both special tools and common tool sets) required for each maintenance function as referenced from the MAC.

The remarks (immediately following the tools and test equipment requirements) contain supplemental instructions and explanatory notes for a particular maintenance function.

**Maintenance Functions**

Maintenance functions will be limited to and are defined as follows:

1. Inspect. To determine the serviceability of an item by comparing its physical, mechanical, and/or electrical characteristics with established standards through examination (e.g., by sight, sound, or feel.) This includes scheduled inspection and gagings and evaluation of cannon tubes.
2. Test. To verify serviceability by measuring the mechanical, pneumatic, hydraulic, or electrical characteristics of an item and comparing those characteristics with prescribed standards on a scheduled basis, i.e., load testing of lift devices and hydrostatic testing of pressure hoses.
3. Service. Operations required periodically to keep an item in proper operating condition, e.g., to clean (includes decontaminate, when required), to preserve, to drain, to paint, or to replenish fuel, lubricants, chemical fluids, or gases. This includes scheduled exercising and purging of recoil mechanisms. The following are examples of service functions:
  - a. Unpack. To remove from packing box for service or when required for the performance of maintenance operations.
  - b. Repack. To return item to packing box after service and other maintenance operations.
  - c. Clean. To rid the item of contamination.
  - d. Touch up. To spot paint scratched or blistered surfaces.

---

**CARGO BED COVER (CBC), TYPE III, 2 1/2 T CARGO TRUCK, LMTV, AND LMTV TRAILER 0041 00  
MAINTENANCE ALLOCATION CHART (MAC)**

---

- e. Mark. To restore obliterated identification.
- 4. Adjust. To maintain or regulate, within prescribed limits, by bringing into proper or exact position, or by setting the operating characteristics to specified parameters.
- 5. Align. To adjust specified variable elements of an item to bring about optimum or desired performance
- 6. Calibrate. To determine and cause corrections to be made, or to be adjusted on instruments of test, measuring, and diagnostic equipment used in precision measurement. Consists of comparisons of two instruments, one of which is a certified standard of known accuracy, to detect and adjust any discrepancy in the accuracy of the instrument being compared.
- 7. Remove/Install. To remove and install the same item when required to perform service or other maintenance functions. Install may be the act of emplacing, seating, or fixing into position a spare, repair part, or module (component or assembly) in a manner to allow the proper functioning of an equipment or system.
- 8. Paint. To prepare and spray color coats of paint so that the ammunition can be identified and protected. The color indicating primary use is applied, preferably, to the entire exterior surface as the background color of the item. Other markings are to be repainted as original so as to retain proper ammunition identification.
- 9. Replace. To remove an unserviceable item and install a serviceable counterpart in its place. "Replace" is authorized by the MAC and assigned maintenance level is shown as the third position code of the Source, Maintenance and Recoverability (SMR) code.
- 10. Repair. The application of maintenance services, including fault location/troubleshooting, removal/installation, disassembly/assembly procedures and maintenance actions to identify troubles and restore serviceability to an item by correcting specific damage, fault, malfunction, or failure in a part, subassembly, module (component or assembly), end item, or system.

**NOTE**

The following definitions are applicable to the "repair" maintenance function:

Services. Inspect, test, service, adjust, align, calibrate, and/or replace.

Fault location/troubleshooting. The process of investigating and detecting the cause of equipment malfunctioning; the act of isolating a fault within a system or Unit Under Test (UUT).

Disassembly/assembly. The step by step breakdown (taking apart) of a spare/functional group coded item to the level of its least component, that is assigned an SMR code for the level of maintenance under consideration (i.e., identified as maintenance significant).

Actions. Welding, grinding, riveting, straightening, facing, machining, and/or resurfacing.

---

**CARGO BED COVER (CBC), TYPE III, 2 1/2 T CARGO TRUCK, LMTV, AND LMTV TRAILER 0041 00  
MAINTENANCE ALLOCATION CHART (MAC)**

---

11. Overhaul. That maintenance effort (service/action) prescribed to restore an item to a completely serviceable/operational condition as required by maintenance standards in appropriate technical publications. Overhaul is normally the highest degree of maintenance performed by the Army. Overhaul does not normally return an item to like new condition.
12. Rebuild. Consists of those services/actions necessary for the restoration of unserviceable equipment to a like new condition in accordance with original manufacturing standards. Rebuild is the highest degree of material maintenance applied to Army equipment. The rebuild operation includes the act of returning to zero those age measurements (hours/miles, etc.) considered in classifying Army equipment/components.

**Explanation of Columns in the MAC**

Column (1) Group Number. Column (1) lists Functional Group Code (FGC) numbers, the purpose of which is to identify maintenance significant components, assemblies, subassemblies, and modules with the Next Higher Assembly (NHA).

Column (2) Component/Assembly. Column (2) contains the names of components, assemblies, subassemblies, and modules for which maintenance is authorized.

Column (3) Maintenance Function. Column (3) lists the functions to be performed on the item listed in column (2). (For detailed explanation of these functions refer to "Maintenance Functions" outlined above).

Column (4) Maintenance Level. Column (4) specifies each level of maintenance authorized to perform each function listed in column (3), by indicating work time required (expressed as manhours in whole hours or decimals) in the appropriate subcolumn. This work time figure represents the active time required to perform that maintenance function at the indicated level of maintenance. If the number or complexity of the tasks within the listed maintenance function varies at different maintenance levels, appropriate work time figures are to be shown for each level. The work time figure represents the average time required to restore an item (assembly, subassembly, component, module, end item, or system) to a serviceable condition under typical field operating conditions. This time includes preparation time (including any necessary disassembly/assembly time), troubleshooting/fault location time, and quality assurance time in addition to the time required to perform the specific tasks identified for the maintenance functions authorized in the MAC. The system designations for the various maintenance levels are as follows:

Field:

- C Operator or crew maintenance
- O Unit Maintenance
- F Direct Support Maintenance

Sustainment:

- L Specialized Repair Activity
- H General Support Maintenance
- D Depot Maintenance

---

**CARGO BED COVER (CBC), TYPE III, 2 1/2 T CARGO TRUCK, LMTV, AND LMTV TRAILER 0041 00  
MAINTENANCE ALLOCATION CHART (MAC)**

---

**NOTE**

The "L" maintenance level is not included in column (4) of the MAC. Functions to this level of maintenance are identified by work time figure in the "H" column of column (4), and an associated reference code is used in the REMARKS column (6). This code is keyed to the remarks and the SRA complete repair application is explained there.

Column (5) Tools and Equipment Reference Code. Column (5) specifies, by code, those common tool sets (not individual tools), common Test, Measurement and Diagnostic Equipment (TMDE), and special tools, special TMDE, and support equipment required to perform the designated function. Codes are keyed to the entries in the tools and test equipment table.

Column (6) Remarks Code. When applicable, this column contains a letter code, in alphabetic order, which is keyed to the remarks table entries.

**Explanation of Columns in the Tools and Test Equipment Requirements**

Column (1) - Tool or Test Equipment Reference Code. The tool or test equipment reference code correlates with a code used in column (5) of the MAC.

Column (2) - Maintenance Level. The lowest level of maintenance authorized to use the tool or test equipment.

Column (3) - Nomenclature. Name or identification of tool or test equipment.

Column (4) - National Stock Number (NSN). The NSN of the tool or test equipment.

Column (5) - Tool Number. The manufacturer's part number.

**Explanation of Columns in Remarks**

Column (1) - Remarks Code. The code recorded in column (6) of the MAC.

Column (2) - Remarks. This column lists information pertinent to the maintenance function being performed as indicated in the MAC.



**CARGO BED COVER (CBC), TYPE III, 2 1/2 T CARGO TRUCK, LMTV, AND LMTV TRAILER 0041 00  
MAINTENANCE ALLOCATION CHART (MAC)**

**Table 1. MAC for Cargo Bed Cover (CBC), Type III, 2 1/2 T Cargo Truck, LMTV, and LMTV Trailer**

(1) GROUP NUMBER	(2) COMPONENT/ ASSEMBLY	(3) MAINTENANCE FUNCTION	(4) MAINTENANCE LEVEL					(5) TOOLS AND TEST EQUIPMENT REFERENCE CODE	(6) REMARKS
			FIELD		SUSTAINMENT				
			UNIT		DIRECT SUPPORT	GENERAL SUPPORT	DEPOT		
			C	O	F	H	D		
00	CARGO BED COVER (CBC), 5 T CARGO TRUCK, MTV, AND MTV TRAILER								
01	UPPER EXTENDABLE SECTION	Inspect Repair Replace	0.6 0.4 1.0	0.4 2.0 1.0	1.0			A C	
0101	ROOF ACCESS HANDHOLD	Inspect Replace	0.1 0.1	0.1 0.2			1		
0102	UPPER ROOF ACCESS STEP	Inspect Replace	0.1 0.1	0.1 0.2			1		
0103	LIFTING RINGS	Inspect Replace	0.1 0.1	0.1 0.2			1		
0104	AIR FILTER	Inspect Service Replace	0.1 0.1	0.2			1	D	
0105	LIFTING/ LOCKING ASSEMBLY	Inspect Replace	0.1 0.1	0.1 0.2			1		
02	LOWER STATIONARY SECTION	Inspect Service Repair Replace	0.4 0.4 1.0 2.7	0.4 0.1 1.0 2.7	1.0		1 1	A B	
0201	WINCH ASSEMBLY	Inspect Service Replace	0.2 0.2 2.0	0.2 0.1 2.0			1	B	
0202	LOWER ROOF ACCESS STEP	Inspect Replace	0.1 0.1	0.1 0.2			1		
0203	CARRIER MOUNTING ANGLES	Inspect Replace	0.1 0.1	0.1 0.5			1	E	
0204	WINCH CABLE ASSEMBLY	Inspect Replace	0.2 0.2	0.2 2.5			1		

**CARGO BED COVER (CBC), TYPE III, 2 1/2 T CARGO TRUCK, LMTV, AND LMTV TRAILER 0041 00  
MAINTENANCE ALLOCATION CHART (MAC)**

**Table 1. MAC for Cargo Bed Cover (CBC), Type III, 2 1/2 T Cargo Truck,  
LMTV, and LMTV Trailer – Continued.**

(1) GROUP NUMBER	(2) COMPONENT/ ASSEMBLY	(3) MAINTENANCE FUNCTION	(4) MAINTENANCE LEVEL					(5) TOOLS AND TEST EQUIPMENT REFERENCE CODE	(6) REMARKS
			FIELD		SUSTAINMENT				
			UNIT		DIRECT SUPPORT	GENERAL SUPPORT	DEPOT		
			C	O	F	H	D		
03	PERSONNEL DOOR	Inspect	0.2	0.2				1	A B
		Service	0.2						
		Replace		1.0					
0301	UPPER PERSONNEL DOOR	Inspect	0.1	0.1				1	B
		Service	0.1						
		Replace		0.5					
0302	LOWER PERSONNEL DOOR	Inspect	0.1	0.1				1	B
		Service	0.1						
		Replace		0.5					
04	VEHICLE MOUNTING PLATE	Inspect	0.2	0.2				1 1	F
		Repair		0.5					
		Replace		2.0					

**CARGO BED COVER (CBC), TYPE III, 2 1/2 T CARGO TRUCK, LMTV, AND LMTV TRAILER 0041 00  
MAINTENANCE ALLOCATION CHART (MAC)**

**Table 2. Tools and Test Equipment for Cargo Bed Cover (CBC),  
Type III, 2 1/2 T Cargo Truck, LMTV, and LMTV Trailer**

(1) TOOL OR TEST EQUIPMENT REFERENCE CODE	(2) MAINTENANCE LEVEL	(3) NOMENCLATURE	(4) NATIONAL STOCK NUMBER	(5) TOOL NUMBER
1	O	Tool Kit, General Mechanic's	5180-00-177-7033	12B470000-1
2	O	Light, Incandescent, Adjustable with Tripod Base	6230-01-339-9660	8439K51 (39428)
3	O	Goggles, Industrial	4240-00-052-3776	GG-G-531 (81348)
4	O	Drill, Electric, Portable	5130-00-935-7354	6635 (55111)
5	O	Drill Set, Twist	5133-00-293-0983	GGG-D-751 (81348)
6	O	Gloves, Chemical Protective	8415-00-266-8675	ZZ-G-381 (81348)
7	O	Dispenser, Sealant	5120-01-322-3634	7565T4 (39428)
8	O	Drill Set, Twist	5133-01-047-0258	DBM125B (55719)
9	O	Riveter, Blind, Hand	5120-01-289-4310	HP-2 (10054)
10	O	Router, Electric, Portable	5130-00-035-6160	A-A-482 (58536)
11	O	Riveter, Blind, Hand	5120-00-102-6847	C-845-2528L (0VK23)
12	O	Punch, Pin	5120-00-293-1408	3416A15 (39428)
13	O	Riveter, Blind, Hand	5120-01-020-7814	C-722-3124L (0VK23)

**Table 3. Remarks for Cargo Bed Cover (CBC), Type III, 2 1/2 T Cargo Truck,  
LMTV, and LMTV Trailer**

(1) REMARK CODES	(2) REMARKS
A	Perform PMCS.
B	Lubrication Required.
C	Deburr Helicopter Rub Strip prior to airlift.
D	Clean or replace air filter as required.
E	Weatherseal should be removed and replaced when changing Carrier Mounting Angles.
F	Remove and replace threaded studs if required.



**CARGO BED COVER (CBC), TYPE III, 2 1/2 T CARGO TRUCK, LMTV, AND LMTV TRAILER 0042 00  
REPAIR PARTS SPECIAL TOOLS LIST (RPSTL) INTRODUCTION**

---

**INTRODUCTION**

**SCOPE**

This RPSTL lists and authorizes spares and repair parts; special tools; special test, measurement, and diagnostic equipment (TMDE); and other special support equipment required for performance of operator, unit, and direct support maintenance of the Cargo Bed Cover (CBC), 2 1/2 T Cargo Truck, LMTV, and LMTV Trailer. It authorizes the requisitioning, issue, and disposition of spares, repair parts, and special tools as indicated by the source, maintenance, and recoverability (SMR) codes.

**GENERAL**

In addition to the Introduction work package, this RPSTL is divided into the following work packages.

1. Repair Parts List Work Packages. Work packages containing lists of spares and repair parts authorized by this RPSTL for use in the performance of maintenance. These work packages also include parts which must be removed for replacement of the authorized parts. Parts lists are composed of functional groups in ascending alphanumeric sequence, with the parts in each group listed in ascending figure and item number sequence. Sending units, brackets, filters, and bolts are listed with the component they mount on. Bulk materials are listed by item name in FIG. BULK at the end of the work packages. Repair parts kits are listed separately in their own functional group and work package. Repair parts for reparable special tools are also listed in a separate work package. Items listed are shown on the associated illustrations.

2. Special Tools List Work Packages. Work packages containing lists of special tools, special TMDE, and special support equipment authorized by this RPSTL (as indicated by Basis of Issue (BOI) information in the DESCRIPTION AND USABLE ON CODE (UOC) column). Tools that are components of common tool sets and/or Class VII are not listed.

3. Cross-Reference Indexes Work Packages. There are 2 cross-reference indexes work packages in this RPSTL: the National Stock Number (NSN) Index work package, and the Part Number (P/N) Index work package. The National Stock Number Index work package refers you to the figure and item number. The Part Number Index work package refers you to the figure and item number.

**CARGO BED COVER (CBC), TYPE III, 2 1/2 T CARGO TRUCK, LMTV, AND LMTV TRAILER 0042 00  
REPAIR PARTS SPECIAL TOOLS LIST (RPSTL) INTRODUCTION**

**EXPLANATION OF COLUMNS IN THE REPAIR PARTS AND SPECIAL TOOLS LIST (RPSTL)  
WORK PACKAGES**

ITEM NO. (Column (1)). Indicates the number used to identify items called out in the illustration.

SMR CODE (Column (2)). The SMR code containing supply/requisitioning information, maintenance level authorization criteria, and disposition instruction, as shown in the following breakout:

<u>Source Code</u>	<u>Maintenance Code</u>	<u>Recoverability Code</u>
<u>XX</u> 1st two positions: How to get an item.	<u>XX</u> 3rd position: Who can install, replace, or use the item.	<u>X</u> 4th position: Who can do complete repair* on the item. 5th position: Who determines disposition action on unserviceable items.

\*Complete Repair: Maintenance capacity, capability, and authority to perform all corrective maintenance tasks of the "Repair" function in a use/user environment in order to restore serviceability to a failed item.

Source Code. The source code tells you how you get an item needed for maintenance, repair, or overhaul of an end item/equipment. Explanations of source codes follow:

<u>Source Code</u>	<u>Application/Explanation</u>
PA PB PC PD FE	Stock items; use the applicable NSN to requisition/request items with these source codes. They are authorized to the level indicated by the code entered in the 3rd position of the SMR code.
PF PG	 <b>NOTE</b> Items coded PC are subject to deterioration.
KD KF KB	Items with these codes are not to be requested/requisitioned individually. They are part of a kit which is authorized to the maintenance level indicated in the 3rd position of the SMR code. The complete kit must be requisitioned and applied.
MO-Made at unit/ AVUM level MF-Made at DS/ AVIM level	Items with these codes are not to be requisitioned/requested individually. They must be made from bulk material which is identified by the P/N

**CARGO BED COVER (CBC), TYPE III, 2 1/2 T CARGO TRUCK, LMTV, AND LMTV TRAILER 0042 00  
REPAIR PARTS SPECIAL TOOLS LIST (RPSTL) INTRODUCTION**

<p>MH-Made at GS level ML-Made at SRA MD-Made at depot</p>	<p>in the DESCRIPTION AND USABLE ON CODE (UOC) column and listed in the bulk material group work package of the RPSTL. If the item is authorized to you by the 3rd position code of the SMR code, but the source code indicates it is made at higher level, order the item from the higher level of maintenance.</p>
<p>AO-Assembled by unit/AVUM level AF-Assembled by DS/AVIM level AH-Assembled by GS level AL-Assembled by SRA AD-Assembled by depot</p>	<p>Items with these codes are not to be requested/requisitioned individually. The parts that make up the assembled item must be requisitioned or fabricated and assembled at the level of maintenance indicated by the source code. If the 3rd position of the SMR code authorizes you to replace the item, but the source code indicates the item is assembled at a higher level, order the item from the higher level of maintenance.</p>
<p>XA</p>	<p>Do not requisition an "XA" coded item. Order the next higher assembly. (Refer to NOTE below.)</p>
<p>XE</p>	<p>If an item is not available from salvage, order it using the CAGEC and P/N.</p>
<p>XC</p>	<p>Installation drawings, diagrams, instruction sheets, field service drawings; identified by manufacturer's P/N.</p>
<p>XD</p>	<p>Item is not stocked. Order an XD-coded item through normal supply channels using the CAGEC and P/N given, if no NSN is available.</p>



**NOTE**

Cannibalization or controlled exchange, when authorized, may be used as a source of supply for items with the above source codes except for those items source coded "XA" or those aircraft support items restricted by requirements of AR 750-1.

Maintenance Code. Maintenance codes tell you the level(s) of maintenance authorized to use and repair support items. The maintenance codes are entered in the third and fourth positions of the SMR code as follows:

Third Position. The maintenance code entered in the third position tells you the lowest maintenance level authorized to remove, replace, and use an item. The maintenance code entered in the third position will indicate authorization to the following levels of maintenance:

**CARGO BED COVER (CBC), TYPE III, 2 1/2 T CARGO TRUCK, LMTV, AND LMTV TRAILER 0042 00  
REPAIR PARTS SPECIAL TOOLS LIST (RPSTL) INTRODUCTION**

**Maintenance**

<u>Code</u>	<u>Application/Explanation</u>
C —	Crew or operator maintenance done within unit/AVUM maintenance.
O —	Unit level/AVUM maintenance can remove, replace, and use the item.
F —	Direct support/AVIM maintenance can remove, replace, and use the item.
H —	General support maintenance can remove, replace, and use the item.
L —	Specialized repair activity can remove, replace, and use the item.
D —	Depot can remove, replace, and use the item.

Fourth Position. The maintenance code entered in the fourth position tells you whether or not the item is to be repaired and identifies the lowest maintenance level with the capability to do complete repair (perform all authorized repair functions).



**NOTE**

Some limited repair may be done on the item at a lower level of maintenance, if authorized by the Maintenance Allocation Chart (MAC) and SMR codes.

**Maintenance**

<u>Code</u>	<u>Application/Explanation</u>
O —	Unit/AVUM is the lowest level that can do complete repair of the item.
F —	Direct support/AVIM is the lowest level that can do complete repair of the item. H — General support is the lowest level that can do complete repair of the item.
L —	Specialized repair activity, Direct Support (DS) is the lowest level that can do complete repair of the item.
D —	Depot is the lowest level that can do complete repair of the item. Z — Nonreparable. No repair is authorized.
B —	No repair is authorized. No parts or special tools are authorized for maintenance of "B" coded item. However, the item may be reconditioned by adjusting, lubricating, etc., at the user level.

Recoverability Code. Recoverability codes are assigned to items to indicate the disposition action on unserviceable items. The recoverability code is shown in the fifth position of the SMR code as follows:

**Recoverability**

<u>Code</u>	<u>Application/Explanation</u>
Z —	Nonreparable item. When unserviceable, condemn and dispose of the item at the level of maintenance shown in the third position of the SMR code.
O —	Reparable item. When uneconomically repairable, condemn and dispose of the item at the unit level.
F —	Reparable item. When uneconomically repairable, condemn and dispose of the item at the direct support level.



**CARGO BED COVER (CBC), TYPE III, 2 1/2 T CARGO TRUCK, LMTV, AND LMTV TRAILER 0042 00  
REPAIR PARTS SPECIAL TOOLS LIST (RPSTL) INTRODUCTION**

- H — Repairable item. When uneconomically repairable, condemn and dispose of the item at the general support level.
- D — Repairable item. When beyond lower level repair capability, return to depot. Condemnation and disposal of item are not authorized below depot level.
- L — Repairable item. Condemnation and disposal not authorized below Specialized Repair Activity (SRA).
- A — Item requires special handling or condemnation procedures because of specific reasons (such as precious metal content, high dollar value, critical material, or hazardous material). Refer to appropriate manuals/directives for specific instructions.

NSN (Column (3)). The NSN for the item is listed in this column.

CAGEC (Column (4)). The Commercial and Government Entity Code (CAGEC) is a five-digit code which is used to identify the manufacturer, distributor, or Government agency/activity that supplies the item.

PART NUMBER (Column (5)). Indicates the primary number used by the manufacturer (individual, company, firm, corporation, or Government activity), which controls the design and characteristics of the item by means of its engineering drawings, specifications, standards, and inspection requirements to identify an item or range of items.



**NOTE**

When you use an NSN to requisition an item, the item you receive may have a different P/N from the number listed.

DESCRIPTION AND USABLE ON CODE (UOC) (Column (6)). This column includes the following information:

1. The federal item name, and when required, a minimum description to identify the item.
2. P/Ns of bulk materials are referenced in this column in the line entry to be manufactured or fabricated.
3. Hardness Critical Item (HCI). A support item that provides the equipment with special protection from electromagnetic pulse (EMP) damage during a nuclear attack.
4. The statement END OF FIGURE appears just below the last item description in column (6) for a given figure in both the repair parts list and special tools list work packages.

QTY (Column (7)). The QTY (quantity per figure) column indicates the quantity of the item used in the breakout shown on the illustration/figure, which is prepared for a functional group, subfunctional group, or an assembly. A "V" appearing in this column instead of a quantity indicates that the quantity is variable and quantity may change from application to application.

**CARGO BED COVER (CBC), TYPE III, 2 1/2 T CARGO TRUCK, LMTV, AND LMTV TRAILER 0042 00  
REPAIR PARTS SPECIAL TOOLS LIST (RPSTL) INTRODUCTION**

**EXPLANATION OF CROSS-REFERENCE INDEXES WORK PACKAGES FORMAT AND COLUMNS**

1. National Stock Number (NSN) Index Work Package.

STOCK NUMBER Column. This column lists the NSN in National item identification number (NIIN) sequence. The NIIN consists of the last nine digits of the NSN.

NSN  
 (e.g., 5385-01-574-1476)  
 NIIN

When using this column to locate an item, ignore the first four digits of the NSN. However, the complete NSN should be used when ordering items by stock number.

FIG. Column. This column lists the number of the figure where the item is identified/located. The figures are in numerical order in the repair parts list and special tools list work packages.

ITEM Column. The item number identifies the item associated with the figure listed in the adjacent FIG. column. This item is also identified by the NSN listed on the same line.

2. Part Number (P/N) Index Work Package. P/Ns in this index are listed in ascending alphanumeric sequence (vertical arrangement of letter and number combinations which places the first letter or digit of each group in order A through Z, followed by the numbers 0 through 9 and each following letter or digit in like order).

PART NUMBER Column. Indicates the P/N assigned to the item.

FIG. Column. This column lists the number of the figure where the item is identified/located in the repair parts list and special tools list work packages.

ITEM Column. The item number is the number assigned to the item as it appears in the figure referenced in the adjacent figure number column.”

REFERENCE DESIGNATOR Column. Indicates the reference designator assigned to the item.

FIG. Column. This column lists the number of the figure where the item is identified/located in the repair parts list or special tools list work package.

ITEM Column. The item number is the number assigned to the item as it appears in the figure referenced in the adjacent figure number column.

**SPECIAL INFORMATION**

UOC. The UOC appears in the lower left corner of the Description Column heading. Usable on codes are shown as “UOC: ..” in the Description Column (justified left) on the first line under the applicable item/nomenclature. Uncoded items are applicable to all models. Identification of the UOCs used in the RPSTL are:

**CARGO BED COVER (CBC), TYPE III, 2 1/2 T CARGO TRUCK, LMTV, AND LMTV TRAILER 0042 00  
REPAIR PARTS SPECIAL TOOLS LIST (RPSTL) INTRODUCTION**

<u>Code</u>	<u>Used On</u>
FQV	CARGO BED COVER, For 2 1/2 T Vehicles
ABN	M35A2, 2 1/2 T Cargo Truck
LAB	M1078, 2 1/2 T LMTV
LTA	M1082, 2 1/2 T LMTV Trailer

Fabrication Instructions. Bulk materials required to manufacture items are listed in the bulk material functional group of this RPSTL. Part numbers for bulk material are also referenced in the Description Column of the line item entry for the item to be manufactured/fabricated. Detailed fabrication instructions for items source coded to be manufactured or fabricated are found in this TM.

Index Numbers. Items which have the word BULK in the figure column will have an index number shown in the item number column. This index number is a cross-reference between the NSN / P/N index work packages and the bulk material list in the repair parts list work package.

**HOW TO LOCATE REPAIR PARTS**

1. When NSNs or P/Ns Are Not Known.

First. Using the table of contents, determine the assembly group to which the item belongs. This is necessary since figures are prepared for assembly groups and subassembly groups, and lists are divided into the same groups.

Second. Find the figure covering the functional group or the subfunctional group to which the item belongs.

Third. Identify the item on the figure and note the number(s).

Fourth. Look in the repair parts list work packages for the figure and item numbers. The NSNs and part numbers are on the same line as the associated item numbers.

2. When NSN Is Known.

First. If you have the NSN, look in the STOCK NUMBER column of the NSN index work package. The NSN is arranged in NIIN sequence. Note the figure and item number next to the NSN.

Second. Turn to the figure and locate the item number. Verify that the item is the one you are looking for.

3. When P/N Is Known.

First. If you have the PIN and not the NSN, look in the PART NUMBER column of the PIN index work package. Identify the figure and item number.

Second. Look up the item on the figure in the applicable repair parts list work package.





UNIT MAINTENANCE

CARGO BED COVER (CBC), TYPE III, 2 1/2 T CARGO TRUCK, LMTV, AND LMTV TRAILER

TOP (UPPER) SECTION  
17-1-0259

REPAIR PARTS LIST

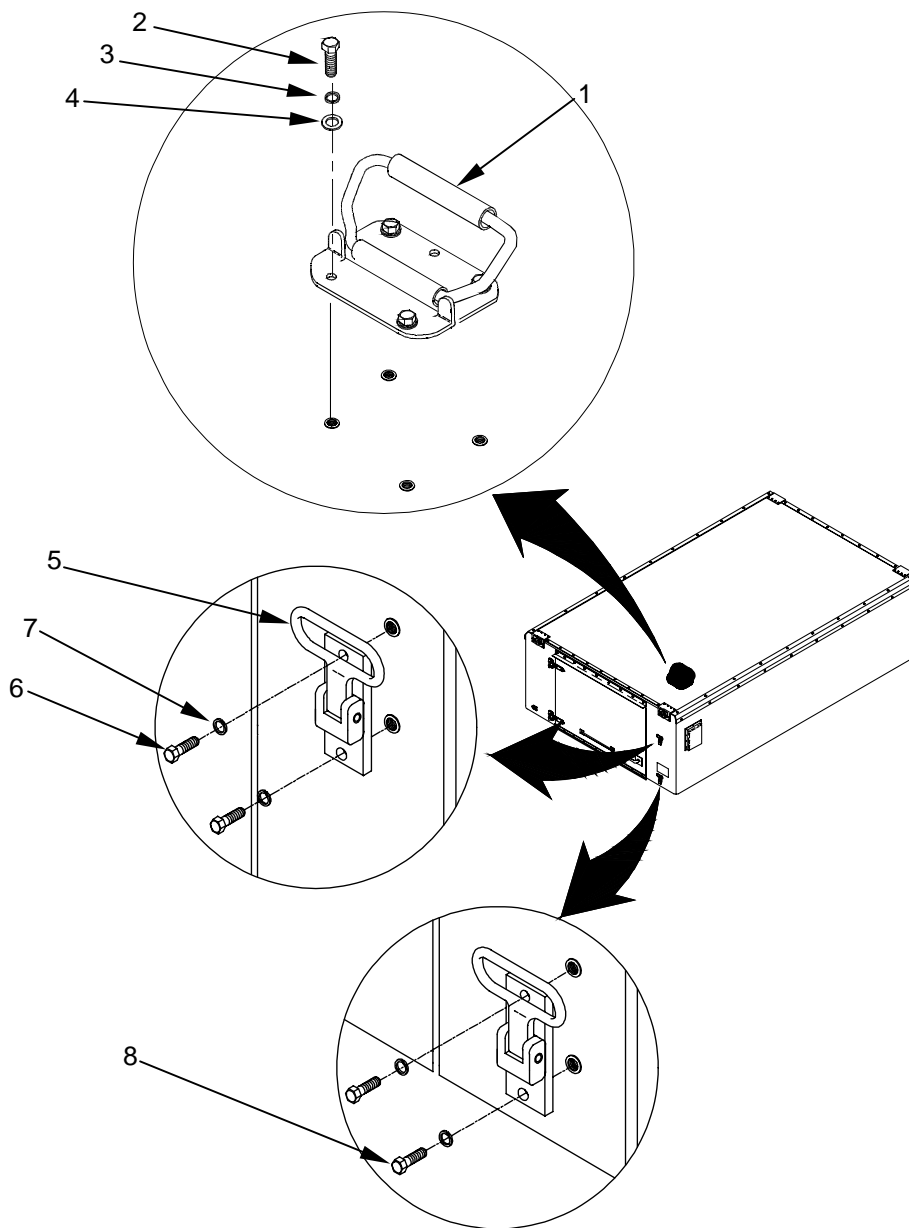

Figure 1. Top (Upper) Section (Sheet 1 of 3)

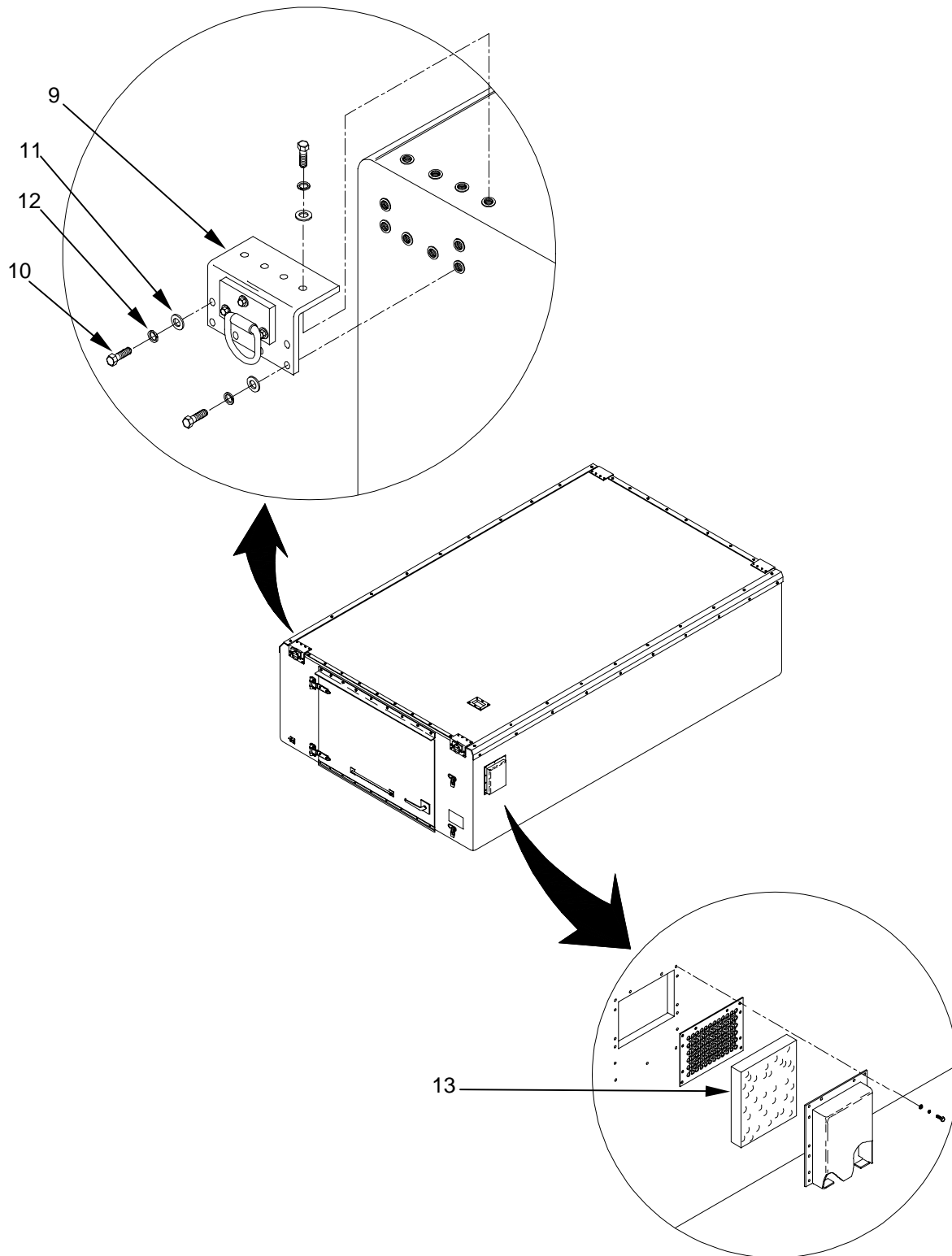

Figure 1. Top (Upper) Section (Sheet 2 of 3)

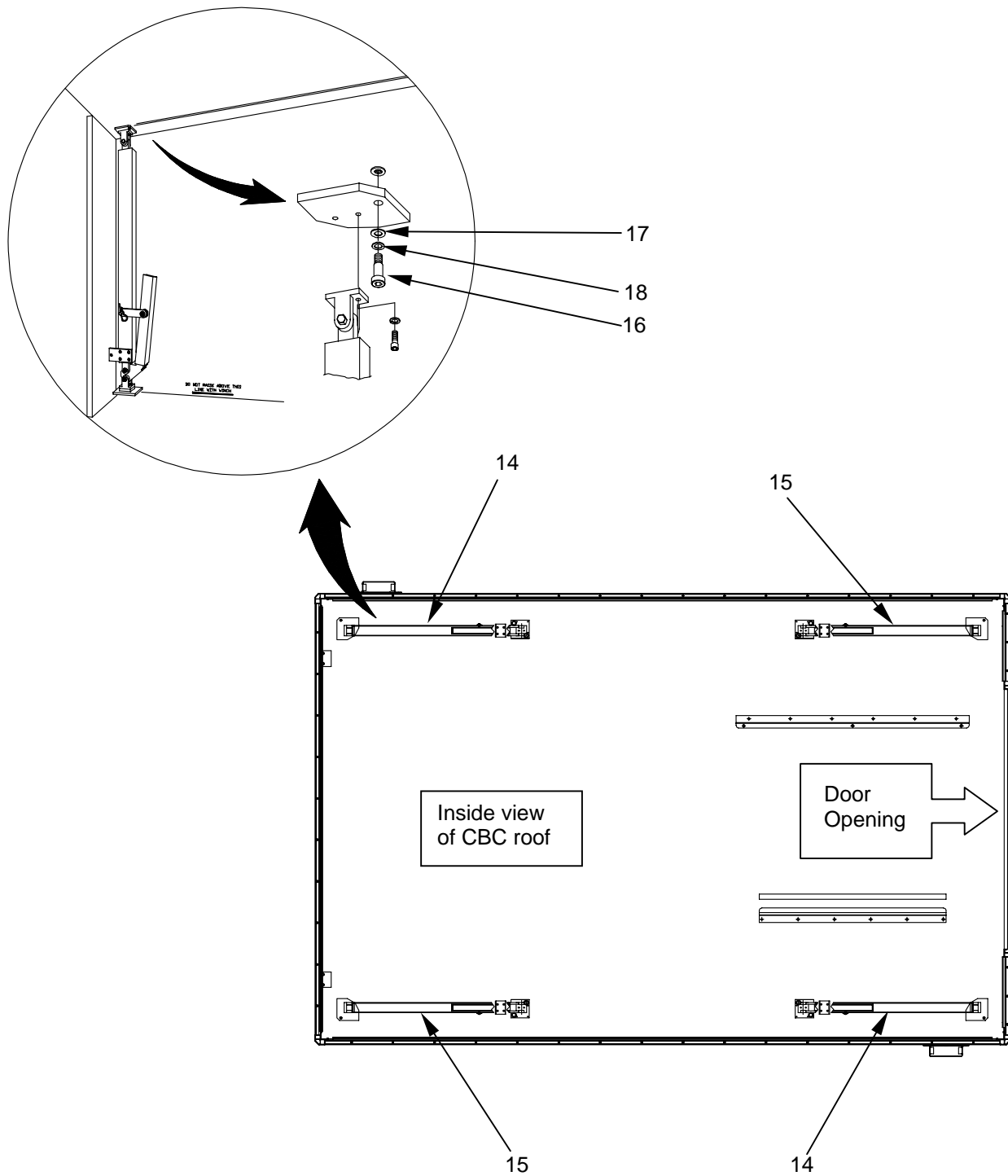

Figure 1. Top (Upper) Section (Sheet 3 of 3)



(1)	(2)	(3)	(4)	(5)	(6)	(7)
ITEM NO.	SMR CODE	NSN	CAGEC	PART NUMBER	DESCRIPTION AND USABLE ON CODE (UOC)	QTY
					GROUP 01	
					FIG. 1 UPPER EXTENDABLE SECTION	
1	PAOZZ	5340014404800	81337	17-1-8555-1	HANDLE,BAIL .....	1
2	PAOZZ	5305000711316	96906	MS51957-80	SCREW, MACHINE (1/4-20 X .625) .....	6
3	PAOZZ	5310014223905	96906	MS35338-139	WASHER, LOCK (1/4).....	6
4	PAOZZ	5310005825677	96906	MS15795-810	WASHER, FLAT (1/4).....	6
5	PAOZZ	5410009194958	19220	1-575709-25	STEP, FOLDING .....	2
6	PAOZZ	5306002264827	80204	B1821BH031C100N	BOLT, MACHINE (5/16-18 X 1.00) .....	3
7	PAOZZ	5310013387338	96906	MS35338-45	WASHER, LOCK (5/16).....	4
8	PAOZZ	5305001451064	80204	B1821BH031C112N	BOLT, MACHINE (5/16-18 X 1.125) .....	1
9	PAOZZ	3940014851651	81337	17-1-0206-1	RING ASSEMBLY, LIFT .....	4
10	PAOZZ	5306002264827	80204	B1821BH031C100N	BOLT, MACHINE (5/16-18 X 1.00) .....	40
11	PAOZZ	5310005825677	96906	MS15795-810	WASHER, FLAT (1/4).....	40
12	PAOZZ	5310014223905	96906	MS35338-139	WASHER, LOCK (1/4).....	40
13	PAOZZ	4130014846764	81337	17-1-0215-1	FILTERING PAD, AIR COOLER.....	2
14	PAOZZ	3940014846758	81337	17-1-0120-1	LOCKING ASSEMBLY, LIFT .....	2
15	XDOZZ	3940014878687	81337	17-1-0120-2	LOCKING ASSEMBLY, LIFT .....	2
16	XDOZZ		39428	91259A576	SCREW, SHOULDER .....	4
17	PAOZZ	5310006806745	96906	MS15795-811	WASHER, FLAT (5/16).....	4
18	PAOZZ	5310001670836	88044	AN960C-516L	WASHER, FLAT (21/64).....	4
					<b>END OF FIGURE</b>	





UNIT MAINTENANCE

CARGO BED COVER (CBC), TYPE III, 2 1/2 T CARGO TRUCK, LMTV, AND LMTV TRAILER

BOTTOM (LOWER) SECTION  
17-1-0260

REPAIR PARTS LIST

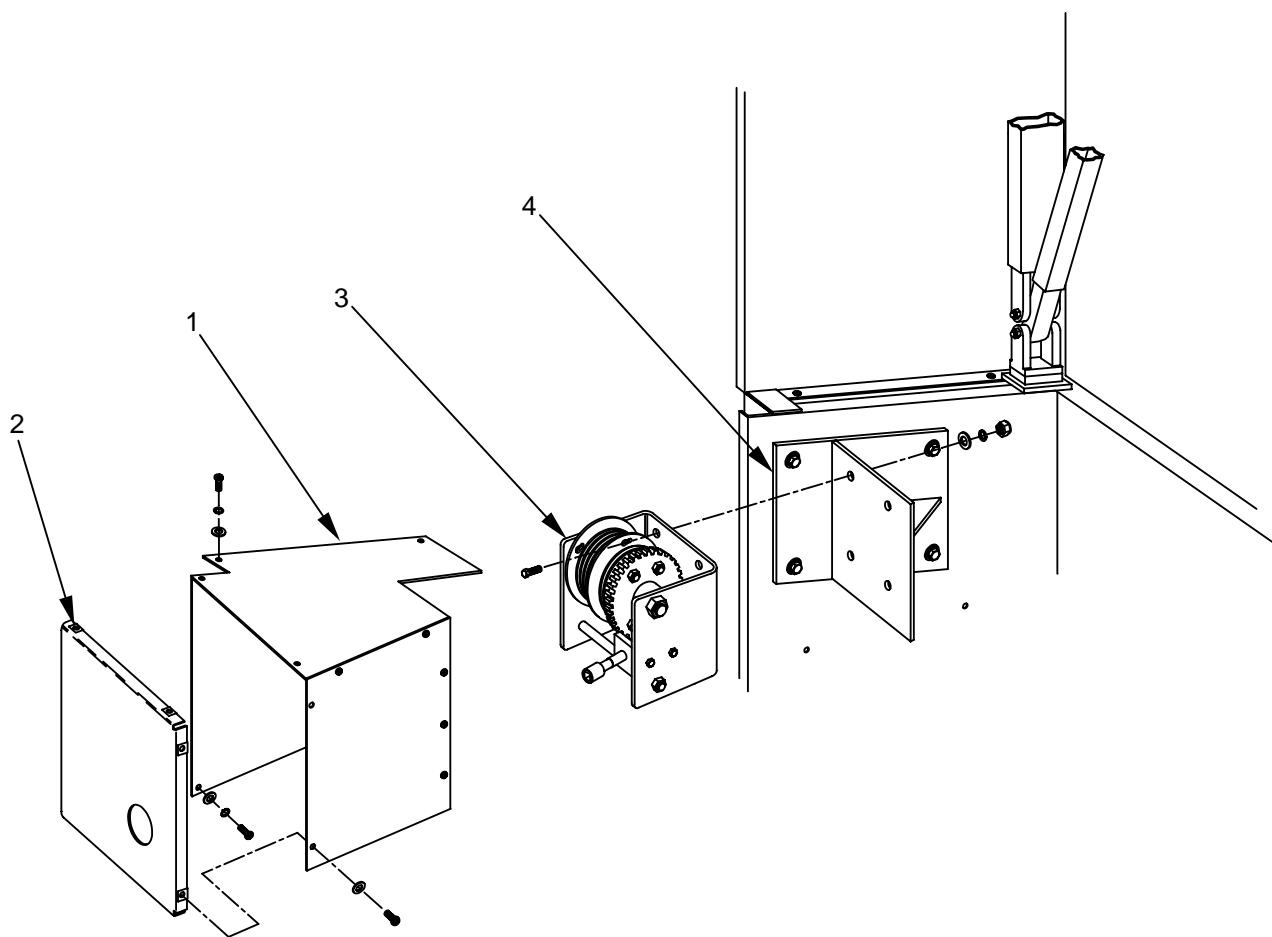

Figure 2. Bottom (Lower) Section (Sheet 1 of 3)

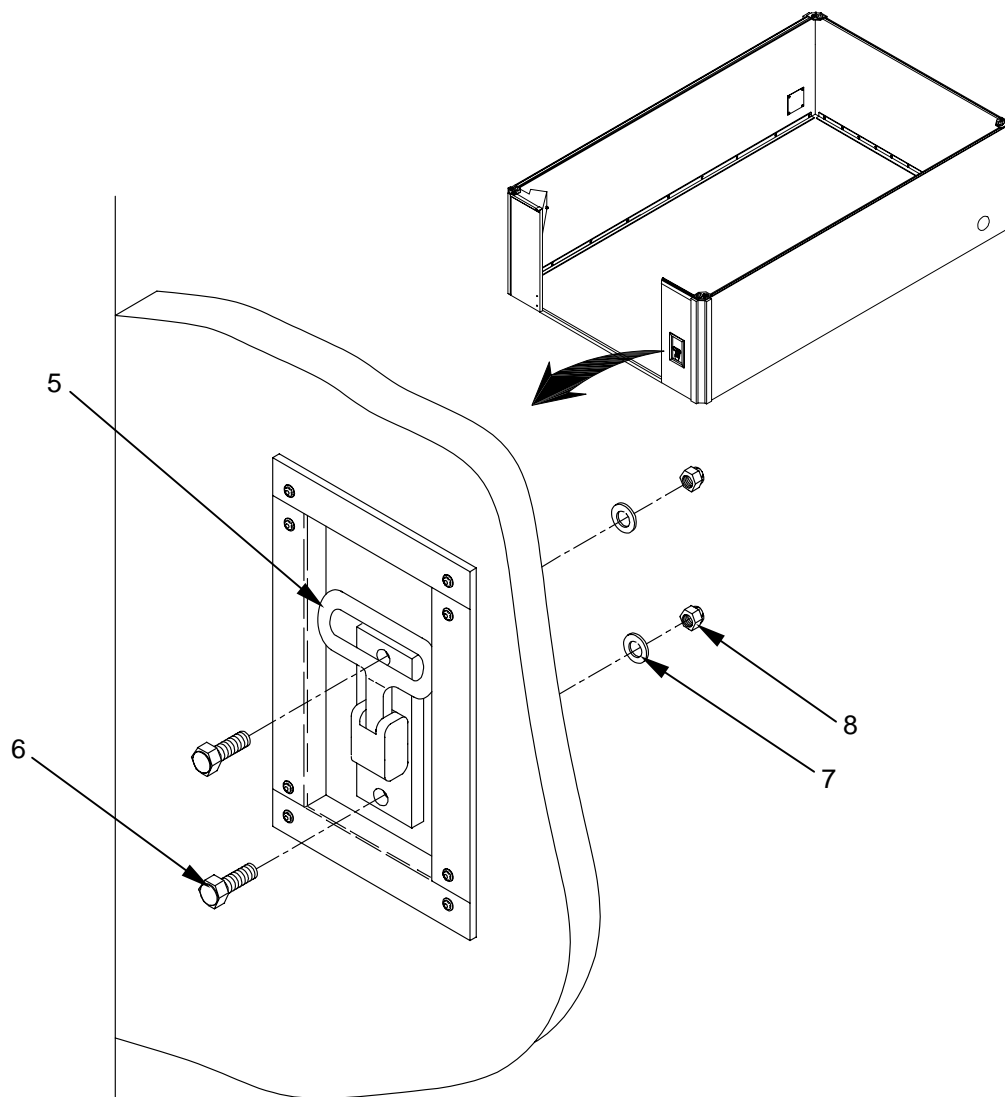

Figure 2. Bottom (Lower) Section (Sheet 2 of 3)

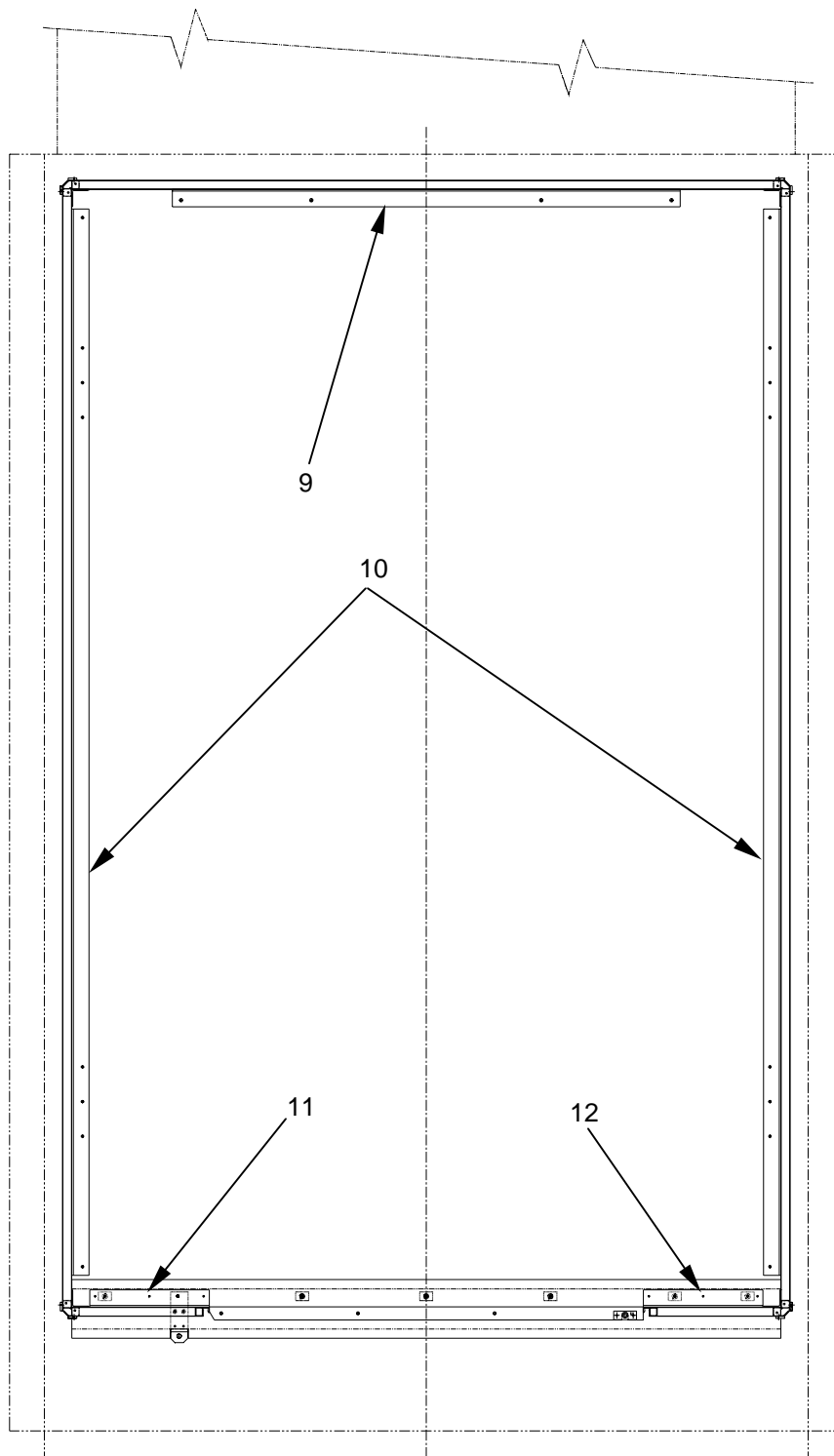

Figure 2. Bottom (Lower) Section (Sheet 3 of 3)

(1)	(2)	(3)	(4)	(5)	(6)	(7)
ITEM NO.	SMR CODE	NSN	CAGEC	PART NUMBER	DESCRIPTION AND USABLE ON CODE (UOC)	QTY
					GROUP 02	
					FIG. 2 LOWER STATIONARY SECTION	
1	PAOZZ	3950014846762	81337	17-1-0307-1	COVER ASSY, WINCH.....	1
2	PAOZZ	3950014846763	81337	17-1-0307-2	COVER ASSY, WINCH.....	1
3	PAOZZ	3950014851649	81337	17-1-0173-1	WINCH, DRUM, HAND OPERATED.....	1
4	PAOZZ	3950014851648	81337	17-1-0134-1	MOUNTING PLATE ASSY.....	1
5	PAOZZ	5410009194958	19220	1-585809-25	STEP, FOLDING.....	1
6	PAOZZ	5306002264827	80204	B1821BH031C100N	BOLT, MACHINE (5/16-18 X 1.25).....	2
7	PAOZZ	5310013896965	80205	MS15795-812	WASHER, FLAT (5/16).....	2
8	XDOZZ		39428	91831A030	NUT, LOCK (5/16).....	2
9	XDOZZ		81337	17-1-0210-1	ANGLE, TIE DOWN, FWD END.....	1
10	XDOZZ		81337	17-1-0209-2	ANGLE, TIE DOWN, SIDE.....	2
11	XDOZZ		81337	17-1-0235-2	ANGLE, MOUNTING.....	1
12	XDOZZ		81337	17-1-0235-1	ANGLE, MOUNTING.....	1
					<b>END OF FIGURE</b>	







UNIT MAINTENANCE

CARGO BED COVER (CBC), TYPE III, 2 1/2 T CARGO TRUCK, LMTV, AND LMTV TRAILER

PERSONNEL DOOR  
17-1-0247

REPAIR PARTS LIST

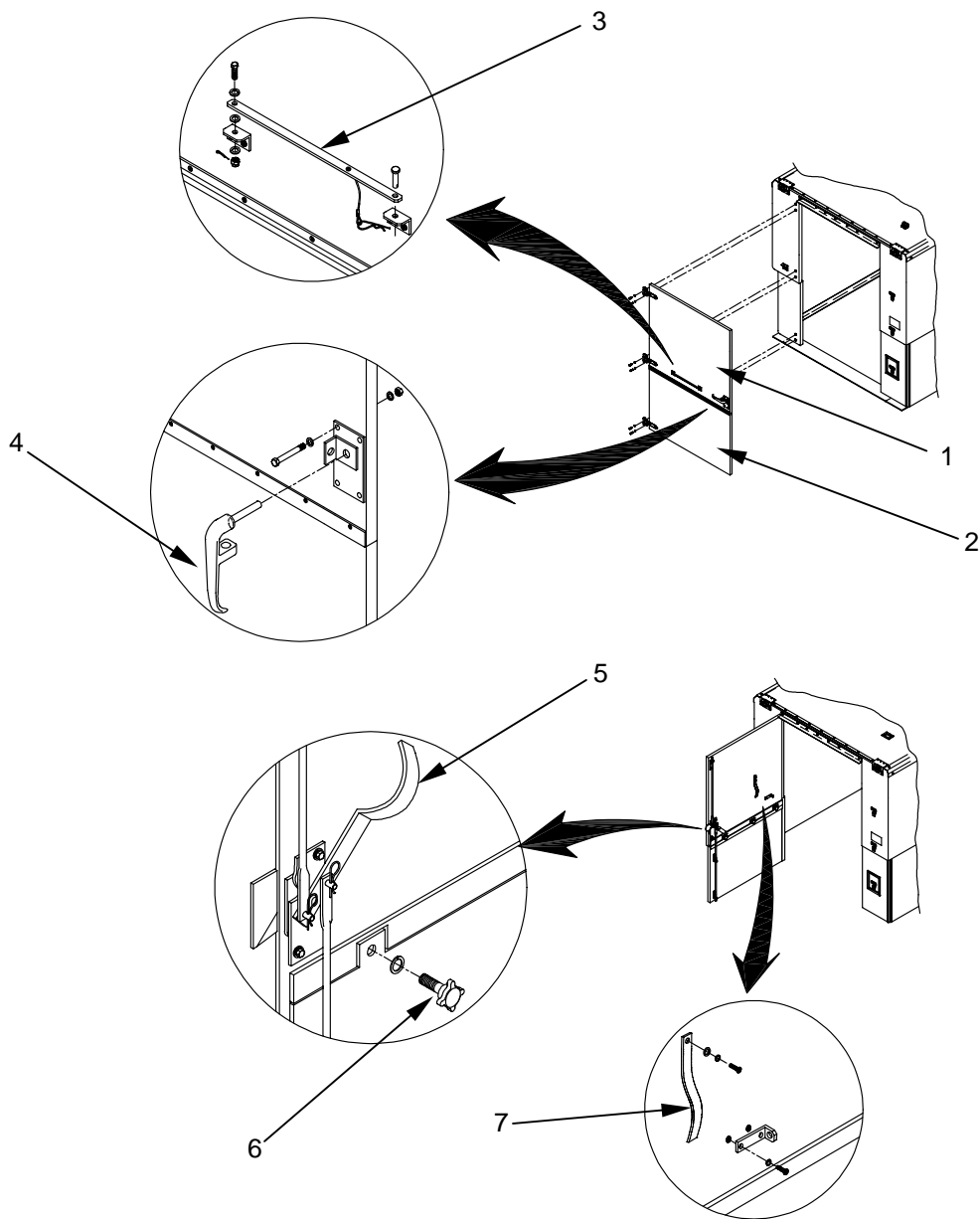

Figure 3. Personnel Door  
0045 00-(1 Blank)/2

(1)	(2)	(3)	(4)	(5)	(6)	(7)
ITEM NO.	SMR CODE	NSN	CAGEC	PART NUMBER	DESCRIPTION AND USABLE ON CODE (UOC)	QTY
					GROUP 03	
					FIG. 3 PERSONNEL DOOR	
1	PAOZZ	5340014851650	81337	17-1-0291-1	DOOR ACCESS, GENERAL PURPOSE.....	1
2	PAOZZ	5340014858345	81337	17-1-0292-1	DOOR ACCESS, GENERAL PURPOSE.....	1
3	PAOZZ	5340014861343	81337	17-1-0171-1	HOLDER ASSEMBLY, DOOR.....	1
4	PAOZZ	5340014846760	81337	17-1-0290-1	HANDLE, DOOR.....	1
5	XDOZZ		27182	311/105	DOOR HANDLE, INSIDE.....	1
6	PAOZZ	5355012420028	99862	CL-3A-HK2T	KNOB.....	3
7	PAOZZ	5340014860254	81337	17-1-0296-1	STRAP HANDLE, UPPER DOOR.....	1
					<b>END OF FIGURE</b>	





UNIT MAINTENANCE

CARGO BED COVER (CBC), TYPE III, 2 1/2 T CARGO TRUCK, LMTV, AND LMTV TRAILER

CBC TO M35A2, 2 1/2 T TRUCK MOUNTING KIT  
17-1-0050

REPAIR PARTS LIST

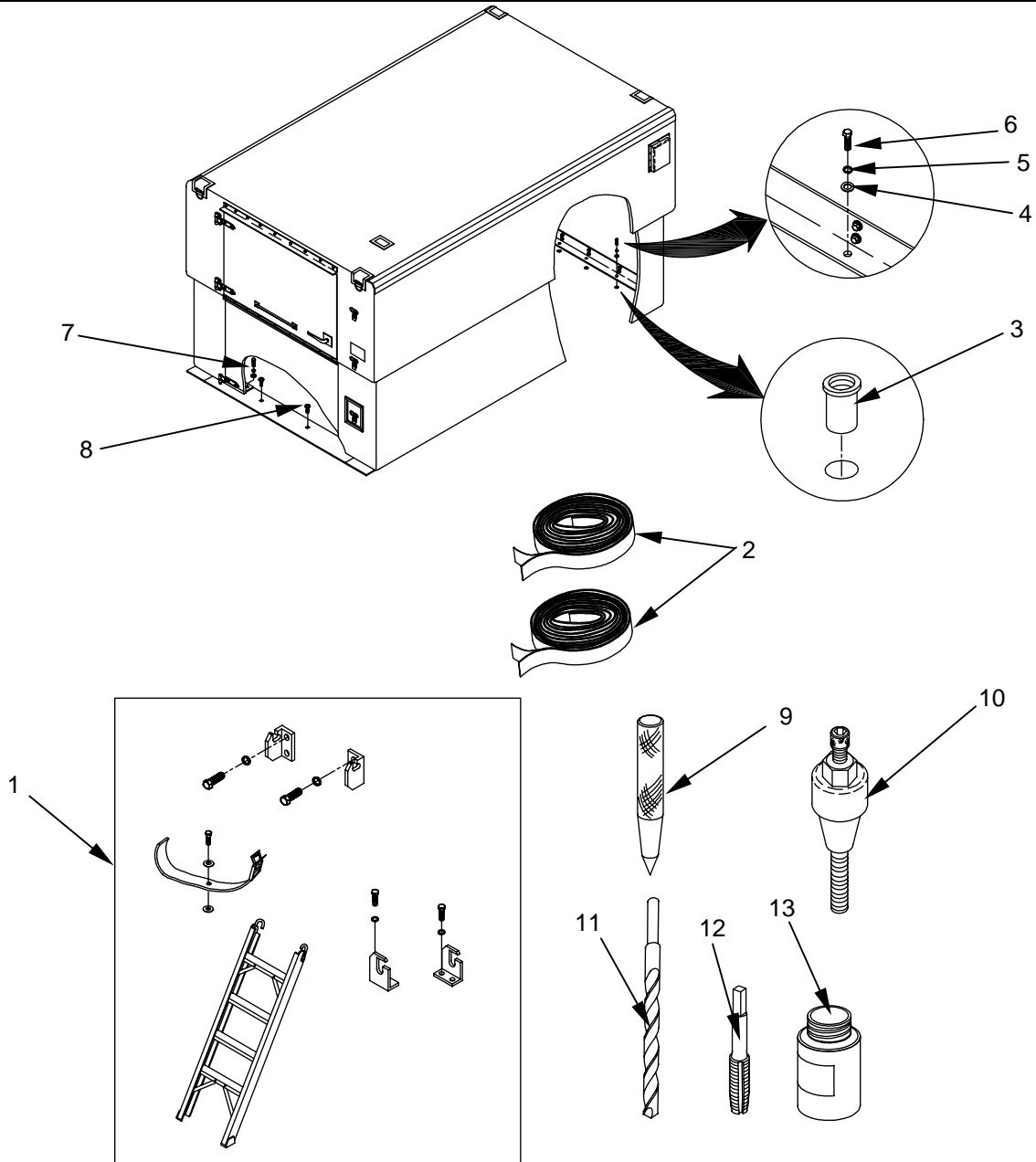

Figure 4. CBC To M35A2, 2 1/2 T Truck Mounting Kit

(1) ITEM NO.	(2) SMR CODE	(3) NSN	(4) CAGEC	(5) PART NUMBER	(6) DESCRIPTION AND USABLE ON CODE (UOC)	(7) QTY
					GROUP 04	
					FIG. 4 CBC TO M35A2, 2 1/2 T TRUCK MOUNTING KIT	
	PAOZZ	5411014868214	81337	17-1-0050	MOUNTING KIT	
1	PAOZZ	2540014851653	81337	17-1-0315-1	LADDER, VEHICLE BOARDING UOC: FQV, ABN.....	1
2	XDOZZ		81337	17-1-0050-3	WEATHERSEAL KIT UOC: FQV, ABN.....	1
3	PAOZZ	5310009523628	0VK23	S31B200	RIVNUT UOC: FQV, ABN.....	19
4	PAOZZ	5310006806745	80205	MS15795-811	WASHER, FLAT (5/16) UOC: FQV, ABN.....	16
5	PAOZZ	5310013387338	96906	MS35338-45	WASHER, LOCK (5/16) UOC: FQV, ABN.....	19
6	PAOZZ	5306012264828	80204	B1821BH031C113N	BOLT, MACHINE (5/16-18 X 1.125) UOC: FQV, ABN.....	12
7	PAOZZ	5306012264830	80204	B1821BH031C138N	BOLT, MACHINE (5/16-18 X 1.375) UOC: FQV, ABN.....	4
8	PAOZZ	5306002264827	80204	B1821BH031C100N	BOLT, MACHINE (5/16-18 X 1.00) UOC: FQV, ABN.....	3
9	PAOZZ	5120002931408	39428	3416A15	PUNCH, PIN UOC: FQV, ABN.....	1
10	PAOZZ	5120010207814	0VK23	C-722-3124L	WRENCH TYPE HEADER (5/16) UOC: FQW,ZAC.....	1
11	XDOZZ		39428	2932A38	DRILL BIT, SIZE (Z) UOC: FQV, ABN.....	1
12	XDOZZ		39428	2521A622	HAND TAP (5/16-18) UOC: FQV, ABN.....	1
13	XDOZZ		39428	1279K31	ANTISEIZE LUBRICANT UOC: FQV, ABN.....	1
<b>END OF FIGURE</b>						







UNIT MAINTENANCE

CARGO BED COVER (CBC), TYPE III, 2 1/2 T CARGO TRUCK, LMTV, AND LMTV TRAILER

CBC TO M1078, 2 1/2 T LMTV MOUNTING KIT  
17-1-0221

REPAIR PARTS LIST

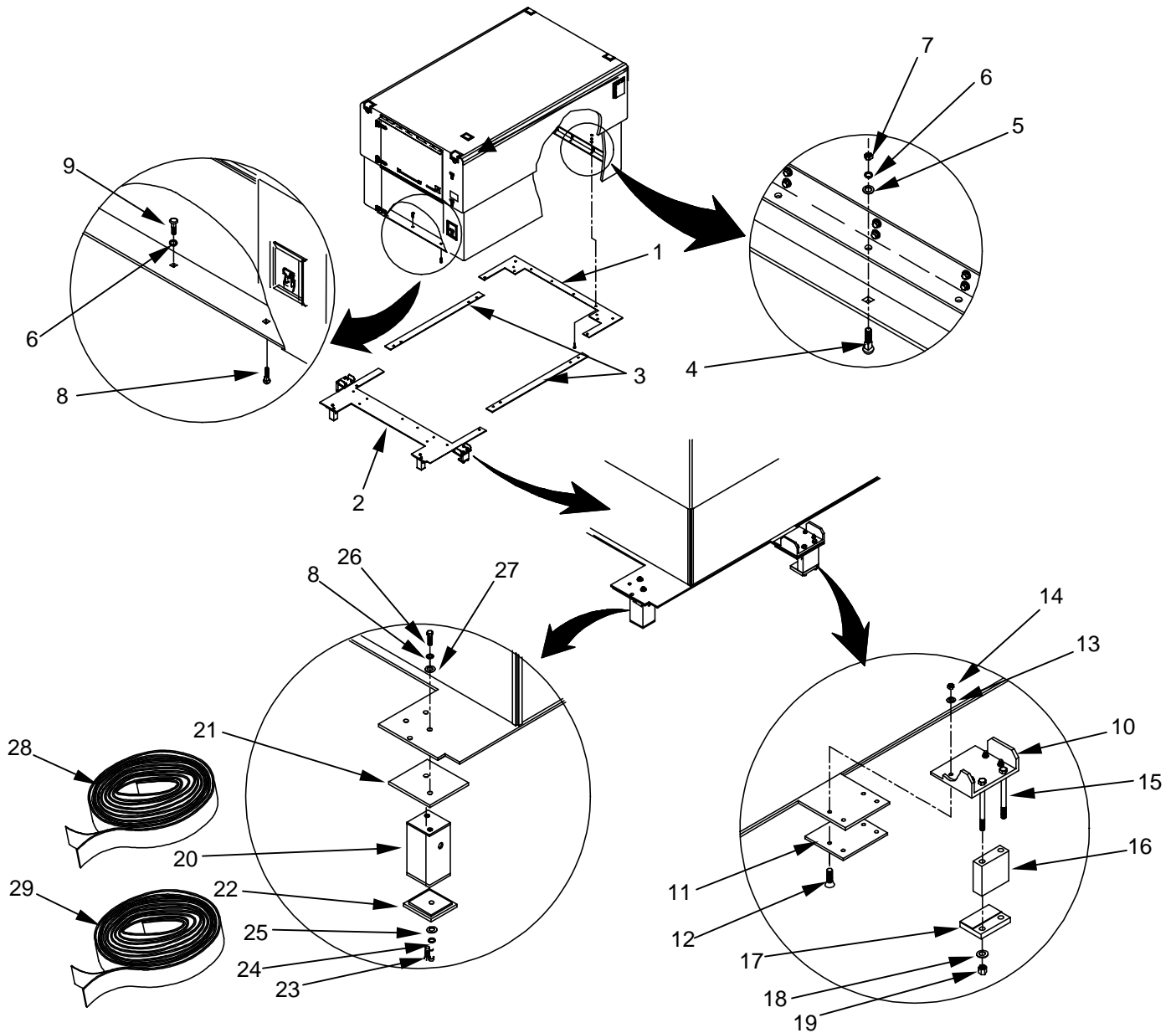

Figure 5. CBC to M1078, 2 1/2 T LMTV Mounting Kit

(1) ITEM NO.	(2) SMR CODE	(3) NSN	(4) CAGEC	(5) PART NUMBER	(6) DESCRIPTION AND USABLE ON CODE (UOC)	(7) QTY
					GROUP 04	
					FIG. 5 VEHICLE MOUNTING KIT M1078	
					2 1/2T LMTV	
					MOUNTING KIT	
	PAOZZ	5411014868213	81337	17-1-0221-1		
1	XDOZZ		81337	17-1-0198-4	PLATE, FWD END UOC: FQV, LTA.....	1
2	XDOZZ		81337	17-1-198-2	PLATE, AFT END-DOOR UOC: FQV, LTA.....	1
3	XDOZZ		81337	17-1-0198-7	PLATE, SIDE UOC: FQV, LTA.....	2
4	XDOZZ		39428	90185A583	BOLT, CARRIAGE (5/16-18 x 1.00) UOC: FQV, LAB .....	20
5	XDOZZ	5310006806745	96906	MS15795-811	WASHER, FLAT (5/16) UOC: FQV, LAB .....	32
6	PAOZZ	5310013387338	96906	MS35338-45	WASHER, LOCK (5/16) UOC: FQV, LAB .....	35
7	XDOZZ		39428	95462A030	NUT (5/16-18) UOC: FQV, LAB .....	24
8	XDOZZ		39428	90185A589	BOLT, CARRIAGE (5/16-18 x 1.25) UOC: FQV, LAB .....	4
9	XDOZZ		39428	90272A6580	SCREW, PH (5/16-18) .63 LG. UOC: FQV, LAB .....	3
10	XDOZZ		81337	17-1-0314-1	MOUNTING DETAILS, CHANNEL UOC: FQV, LAB .....	2
11	XDOZZ		81337	17-1-0314-3	MOUNTING DETAILS, SPACER PLATE UOC: FQV, LAB .....	2
12	PAOZZ	5305007816739	96906	MS24694C152	SCREW, CSK (5/16-24 x 1.28) UOC: FQV, LAB .....	8
13	PAOZZ	5310006806745	96906	MS15795-811	WASHER, FLAT (5/16) UOC: FQV, LAB .....	24
14	PAOZZ	5310009826816	96906	MS21044C5	NUT, SELF-LOCKING HEX (5/16-24) UOC: FQV, LAB .....	8
15	XDOZZ		80204		BOLT (1/2-13 x 4.50) UOC: FQV, LAB .....	4
16	XDOZZ		81337	17-1-0314-2	MOUNTING DETAILS, SPACER UOC: FQV, LAB .....	2
17	XDOZZ		81337	17-1-0327-1	CLAMP PLATE ASSEMBLY UOC: FQV, LAB .....	2
18	PAOZZ	5310007679425	96906	MS15795-818	WASHER, FLAT (1/2) UOC: FQV, LAB .....	4
19	XDOZZ		39428	97135A250	NUT (1/2) UOC: FQV, LAB .....	4
20	XDOZZ		81337	17-1-0197-1	POST, TIE DOWN UOC: FQV, LAB .....	4
21	XDOZZ		81337	17-1-0313-1	PLATE, SPACER UOC: FQV, LAB .....	4
22	XDOZZ		81337	17-1-0237-1	PLATE, BOTTOM UOC: FQV, LAB .....	4
23	XDOZZ		39428	92865A632	BOLT (3/8-16 X 2.00) UOC: FQV, LAB .....	4
24	PAOZZ	5310013859419	96906	MS35338-141	WASHER, LOCK (3/8) UOC: FQV, LAB .....	4
25	PAOZZ	5310013897976	96906	MS15795-814	WASHER, FLAT (3/8) UOC: FQV, LAB .....	4

(1) ITEM NO.	(2) SMR CODE	(3) NSN	(4) CAGEC	(5) PART NUMBER	(6) DESCRIPTION AND USABLE ON CODE (UOC)	(7) QTY
26	XDOZZ		39428	92865A589	BOLT (5/16-18 X 1.75) UOC: FQV, LAB .....	8
27	PAOZZ	5310011670767	88044	AN970-5	WASHER, FLAT (5/16) UOC: FQV, LAB .....	16
28	XDOOZ		39428	93725K58	WEATHERSTRIPPING, 1/8 INCH THK X 1.00 INCH WIDE X 50 FEET LONG, ADHESIVE BACKED, COLOR BLACK, CLOSED CELL, EPDM SPONGE RUBBER STRIP UOC: FQV,LTA.....	1
29	XDOOZ		39428	93725K68	WEATHERSTRIPPING, 3/16 INCH THK X 1.00 INCH WIDE X 50 FEET LONG, ADHESIVE BACKED, COLOR BLACK, CLOSED CELL, EPDM SPONGE RUBBER STRIP UOC: FQV,LTA.....	1
<b>END OF FIGURE</b>						



UNIT MAINTENANCE

CARGO BED COVER (CBC), TYPE III, 2 1/2 T CARGO TRUCK, LMTV, AND LMTV TRAILER

CBC TO M1082, 2 1/2 T LMTV TRAILER MOUNTING KIT  
17-1-0222

REPAIR PARTS LIST

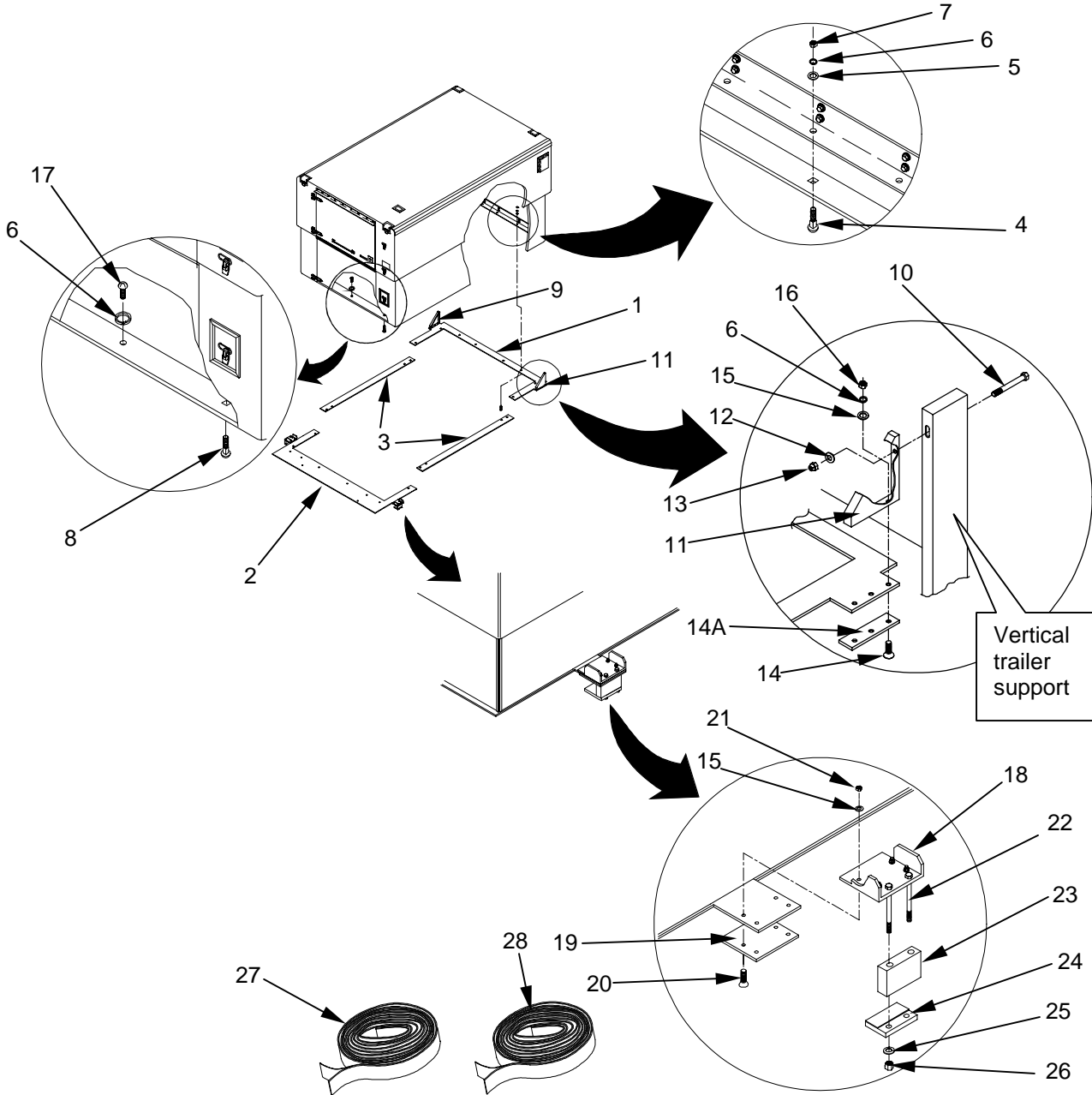

Figure 6. CBC TO M1082, 2 1/2 T LMTV Trailer Mounting Kit

(1)	(2)	(3)	(4)	(5)	(6)	(7)
ITEM NO.	SMR CODE	NSN	CAGEC	PART NUMBER	DESCRIPTION AND USABLE ON CODE (UOC)	QTY
					GROUP 04	
					FIG. 6 VEHICLE MOUNTING KIT M1082 2 1/2T LMTV TRAILER	
1	PAOZZ XDOZZ	5411014868213	81337	17-1-0221-1 17-1-0316-1	MOUNTING KIT PLATE, FWD END UOC: FQV, LTA.....	1
2	XDOZZ		81337	17-1-0317-1	PLATE, AFT END-DOOR UOC: FQV, LTA.....	1
3	XDOZZ		81337	17-1-0198-7	PLATE, SIDE UOC: FQV, LTA.....	2
4	XDOZZ		39428	90185A583	BOLT, CARRIAGE (5/16-18 X 1.00 ) UOC: FQV, LTA.....	20
5	PAOZZ	5310006806745	96906	MS15795-811	WASHER, FLAT (5/16) UOC: FQV, LTA.....	40
6	PAOZZ	5310013387338	96906	MS35338-45	WASHER, LOCK (5/16) UOC: FQV, LTA.....	27
7	XDOZZ		39428	95462A030	NUT (5/16-18) UOC: FQV, LTA.....	24
8	XDOZZ		39428	90185A589	BOLT, CARRIAGE (5/16-18 X 1.25) UOC: FQV, LTA.....	4
9	XDOZZ		81337	17-1-0316-2	BRACKET, LEFT UOC: FQV, LTA.....	1
10	XDOZZ		81337	17-1-0316-3	BRACKET, RIGHT UOC: FQV, LTA.....	1
11	XDOZZ		81346	ASTM 18.2.1	BOLT (7/16-20 X 7.00 LG.) UOC: FQV, LTA.....	2
12	XDOZZ		96906	MS15795-816	WASHER, FLAT (7/16) UOC: FQV, LTA.....	2
13	XDOZZ		96906	MS21044C7	NUT, LOCK (7/16-20) UOC: FQV, LTA.....	2
14	PAOZZ	5305007816739	96906	MS24694C152	SCREW, MACHINE (5/16-24 X 1.28) UOC: FQV, LTA.....	6
14A	XDOZZ		81337	17-1-XXXX	PLATE, SPACER UOC: FQV, LTA.....	2
15	PAOZZ	5310006806745	96906	MS15795-811	WASHER, FLAT (5/16) UOC: FQV, LTA.....	6
16	PAOZZ	5310009826816	96906	MS21044C5	NUT, SELF LOCKING, HEX (5/16-24) UOC: FQV, LTA.....	6
17	XDOZZ		39428	90272A580	SCREW, PH (5/16-18 X .63) UOC: FQV, LTA.....	3
18	XDOZZ		81337	17-1-0314-1	CHANNEL, BRACKET UOC: FQV, LTA.....	2
19	XDOZZ		81337	17-1-0314-3	SPACER PLATE UOC: FQV, LTA.....	4
20	PAOZZ	5305007816739	96906	MS24694C152	SCREW, MACHINE (5/16-24 X 1.28) UOC: FQV, LTA.....	8
21	PAOZZ	5310009826816	96906	MS21044-C5	NUT (5/16-24) UOC: FQV, LTA.....	8
22	PAOZZ	5305000712081	80204	B1821BH050C450N	BOLT (1/2-13 X 4.50) UOC: FQV, LTA.....	8

(1)	(2)	(3)	(4)	(5)	(6)	(7)
ITEM NO.	SMR CODE	NSN	CAGEC	PART NUMBER	DESCRIPTION AND USABLE ON CODE (UOC)	QTY
23	XDOZZ		81337	17-1-0314-2	SPACER UOC: FQV, LTA.....	1
24	XDOZZ		81337	17-1-0327-1	CLAMP PLATE/SEAL ASSEMBLY UOC: FQV, LTA.....	2
25	PAOZZ	5310005432862	96906	MS15795-818	WASHER, FLAT (1/2) UOC: FQV, LTA.....	4
26	XDOZZ		39428	97135A250	NUT (1/2) UOC: FQV, LTA.....	4
27	XDOOZ		39428	93725K58	WEATHERSTRIPPING, 1/8 INCH THK X 1.00 INCH WIDE X 50 FEET LONG, ADHESIVE BACKED, COLOR BLACK, CLOSED CELL, EPDM SPONGE RUBBER STRIP UOC: FQV,LTA.....	1
28	XDOOZ		39428	93725K68	WEATHERSTRIPPING, 3/16 INCH THK X 1.00 INCH WIDE X 50 FEET LONG, ADHESIVE BACKED, COLOR BLACK, CLOSED CELL, EPDM SPONGE RUBBER STRIP UOC: FQV,LTA.....	1
<b>END OF FIGURE</b>						





UNIT MAINTENANCE

CARGO BED COVER (CBC), TYPE III, 2 1/2 T CARGO TRUCK, LMTV, AND LMTV TRAILER

ENTRY LADDER KIT FOR M35A2  
17-1-0315-1

REPAIR PARTS LIST

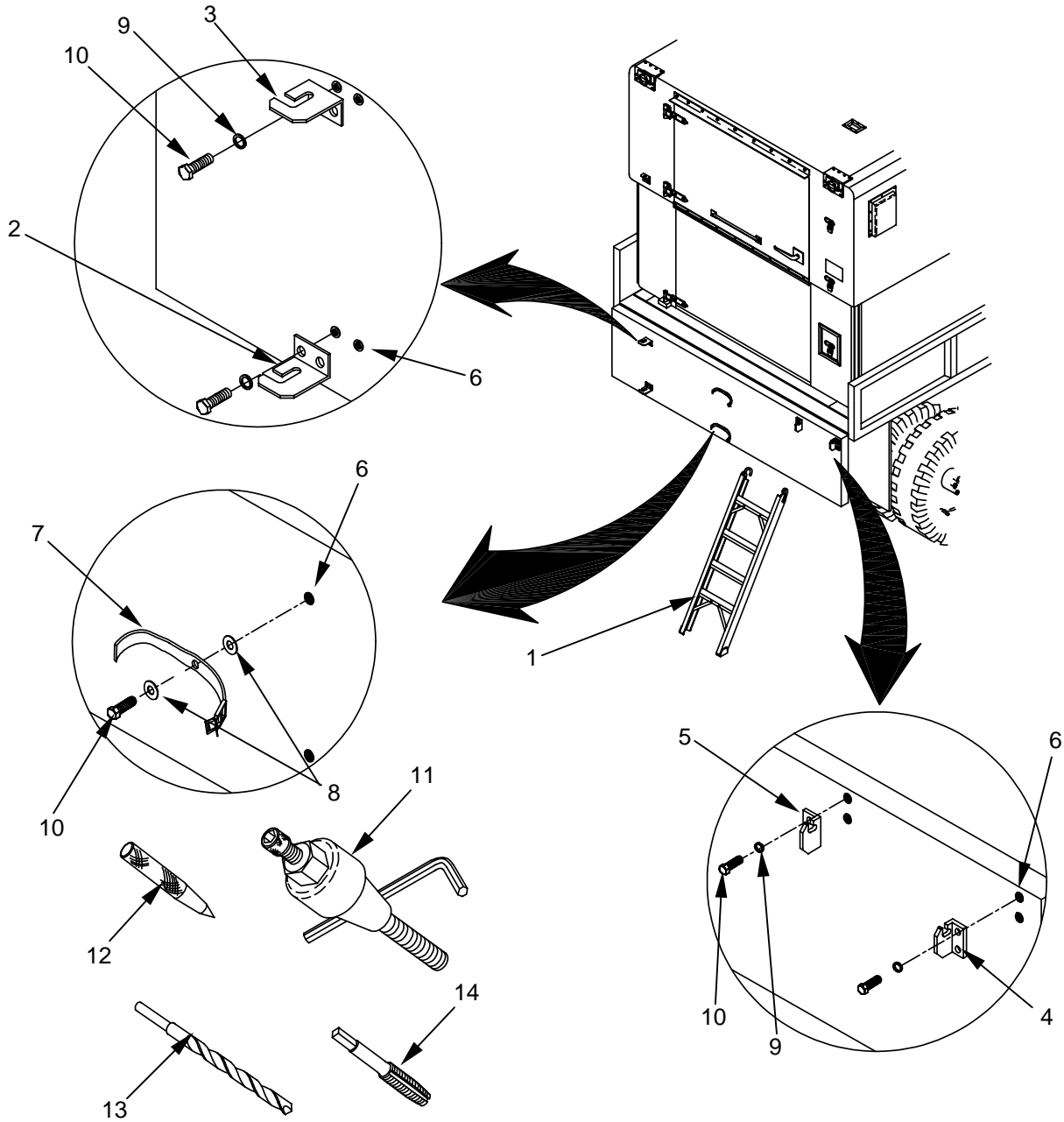

Figure 7. Entry Ladder Kit for M35A2

(1) ITEM NO.	(2) SMR CODE	(3) NSN	(4) CAGEC	(5) PART NUMBER	(6) DESCRIPTION AND USABLE ON CODE (UOC)	(7) QTY
GROUP 04						
FIG. 7 ENTRY LADDER KIT M35A2 2 1/2T CARGO TRUCK						
1	PAOZZ	2540014851653	81337	17-1-0315-1	LADDER VEHICLE BOARDING UOC: FQV, ABN.....	1
2	PAOZZ	5340014860256	81337	17-1-0315-2	BRACKET, ANGLE UOC: FQV, ABN.....	1
3	PAOZZ	5340014860257	81337	17-1-0315-3	BRACKET, ANGLE UOC: FQV, ABN.....	1
4	PAOZZ	5340014863212	81337	17-1-0315-4	BRACKET, ANGLE UOC: FQV, ABN.....	1
5	PAOZZ	5340014863213	81337	17-1-0315-5	BRACKET, ANGLE UOC: FQV, ABN.....	1
6	PAOZZ	5310007630349	96906	MS27131-51	BLIND RIVNUT (1/4-20) UOC: FQV, ABN.....	10
7	PAOZZ	5340014401182	81337	17-1-3618-1	STRAP,WEBBING UOC: FQV, ABN.....	2
8	PAOZZ	5310001670766	80204	AN970-4	WASHER, FLAT (1/4) UOC: FQV, ABN.....	4
9	PAOZZ	5310014223905	96906	MS35338-139	WASHER, LOCK (1/4) UOC: FQV, ABN.....	8
10	PAOZZ	5305001451064	80204	B1821BH025C075N	SCREW, CAP, HEX HD (1/4-20 X .75 LG) UOC: FQV, ABN.....	10
11	PAOZZ	5120001026847	0VK23	C-845-2528L	RIVETER,BLIND,HAND UOC: FQV, ABN.....	1
12	XDOZZ		39428	3374A25	PUNCH,PIN (9/32) UOC: FQV, ABN.....	1
13	XDOZZ		39428	2932A28	DRILL BIT,SIZE (Q) UOC: FQV, ABN.....	1
14	XDOZZ		39428	2521A622	HAND TAP (1/4-20) UOC: FQV, ABN.....	1
<b>END OF FIGURE</b>						





---

UNIT MAINTENANCE

CARGO BED COVER (CBC), TYPE III, 2 1/2 T CARGO TRUCK, LMTV, AND LMTV TRAILER

BULK MATERIALS

REPAIR PARTS LIST

---

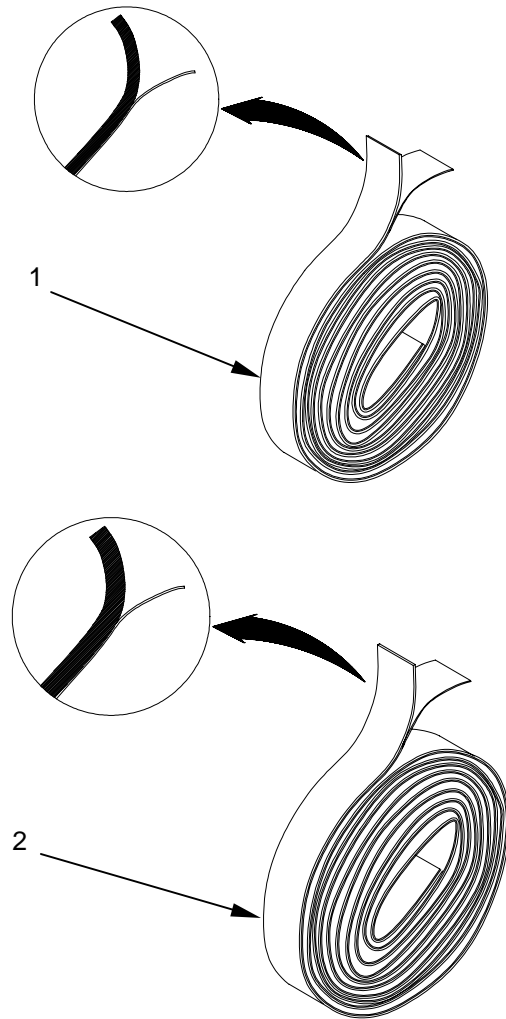

Figure 8. Bulk Materials

(1) ITEM NO.	(2) SMR CODE	(3) NSN	(4) CAGEC	(5) PART NUMBER	(6) DESCRIPTION AND USABLE ON CODE (UOC)	(7) QTY
					GROUP 05 GENERAL USE STANDARDIZED PARTS	
					GROUP 0501 BULK MATERIAL	
					FIG. 8 BULK WEATHERSTRIPPING, 1/8 INCH THK X 1.00 INCH WIDE X 50 FEET LONG, ADHESIVE BACKED, COLOR BLACK, CLOSED CELL, EPDM SPONGE RUBBER STRIP	
1	XDOOZ		39428	93725K58	WEATHERSTRIPPING, 1/8 INCH THK X 1.00 INCH WIDE X 50 FEET LONG, ADHESIVE BACKED, COLOR BLACK, CLOSED CELL, EPDM SPONGE RUBBER STRIP	1
2	XDOOZ		39428	93725K68	WEATHERSTRIPPING, 3/16 INCH THK X 1.00 INCH WIDE X 50 FEET LONG, ADHESIVE BACKED, COLOR BLACK, CLOSED CELL, EPDM SPONGE RUBBER STRIP	1
					<b>END OF FIGURE</b>	





UNIT MAINTENANCE

CARGO BED COVER (CBC), TYPE III, 2 1/2 T CARGO TRUCK, LMTV, AND LMTV TRAILER

NATIONAL STOCK NUMBER INDEX

NSN	FIG.	ITEM
5305	000680508	1 10
5305	000711316	1 2
5305	000712081	6 22
5120	001026847	7 11
5305	001451064	7 10
5310	001670766	7 8
5310	001670836	1 18
5306	002264827	1 6
5306	002264827	1 10
5306	002264827	2 6
5306	002264827	4 8
5120	002931408	4 9
5310	005432862	6 25
5310	005825677	1 4
5310	005825677	1 11
5310	006806745	1 17
5310	006806745	4 4
5310	006806745	5 5
5310	006806745	5 13
5310	006806745	6 5
5310	006806745	6 15
5310	007630349	7 6
5310	007679425	5 18
5305	007816739	5 12
5305	007816739	6 14
5305	007816739	6 20
5410	009194958	1 5
5410	009194958	2 5
5310	009523628	4 3
5310	009826816	5 14
5310	009826816	6 16
5310	009826816	6 21
5120	010207814	4 10
5310	011670767	5 27
5306	012264828	4 6
5306	012264830	4 7
5355	012420028	3 6
5310	013387338	1 7
5310	013387338	4 5
5310	013387338	5 6
5310	013387338	6 6

NSN	FIG.	ITEM
5310	013859419	5 24
5310	013896965	2 7
5310	013897976	5 25
5310	014223905	1 3
5310	014223905	1 12
5310	014223905	7 9
5305	014342945	1 8
5305	014342945	2 6
5340	014401182	7 7
5340	014404800	1 1
3940	014846758	1 14
5340	014846760	3 4
3950	014846762	2 1
3950	014846763	2 2
4130	014846764	1 13
3950	014851648	2 4
3950	014851649	2 3
5340	014851650	3 1
3940	014851651	1 9
2540	014851653	4 1
5340	014851653	7 1
5340	014860256	7 2
5340	014860257	7 3
5340	014863212	7 4
5340	014863213	7 5
5411	014868213	5
5411	014868213	6
5411	014868214	4



UNIT MAINTENANCE

CARGO BED COVER (CBC), TYPE III, 2 1/2 T CARGO TRUCK, LMTV, AND LMTV TRAILER

PART NUMBER INDEX

PART NUMBER	FIG.	ITEM	PART NUMBER	FIG.	ITEM
1279K31	4	13	17-1-0315-4	7	4
1-585809-25	1	5	17-1-0315-5	7	5
	2	5	17-1-0316-1	6	1
17-1-0050	4		17-1-0316-2	6	9
17-1-0050-3	4	2	17-1-0316-3	6	10
17-1-0120-1	1	14	17-1-0317-1	6	2
17-1-0120-2	1	15	17-1-0323-1	7	1
17-1-0134-1	2	4	17-1-0327-1	5	17
17-1-0171-1	3	3		6	24
17-1-0173-1	2	3	17-1-3618-1	7	7
17-1-0197-1	5	20	17-1-8555-1	1	1
17-1-0198-2	5	2	17-1-XXXX	6	14A
17-1-0198-4	5	1	2521A622	4	12
17-1-0198-6	5	4		7	14
17-1-0198-7	5	3	2932A28	7	13
	6	3		4	11
17-1-0206-1	1	9	311/105	3	5
17-1-0209-2	2	10	3374A25	7	12
17-1-0210-1	2	9	3416A15	4	9
			90185A583	5	4
17-1-0215-1	1	13		6	4
17-1-0221-1	5		90185A589	5	8
	6			6	8
17-1-0221-2	5	9	90272A580	6	17
17-1-0235-1	2	12		5	9
17-1-0235-2	2	11	91259A576	1	16
17-1-0237-1	5	22	91831A030	2	8
17-1-0290-1	3	4	92865A589	5	26
17-1-0291-1	3	1	92865A632	5	23
17-1-0292-1	3	2	93725K58	5	28
17-1-0296-1	3	7		6	27
17-1-0307-1	2	1		8	1
17-1-0307-2	2	2	93725K68	5	29
17-1-0313-1	5	21		6	28
17-1-0314-1	5	10		8	2
	6	18	95462A030	5	7
17-1-0314-2	5	16		6	7
	6	23	97135A250	5	19
17-1-0314-3	5	11		6	26
	6	19	AN960-516L	1	18
17-1-0315-1	4	1	AN970-4	7	8
	7	1	AN970-5	5	27
17-1-0315-2	7	2	ASTM 18.2.1	6	11
17-1-0315-3	7	3	B1821BH025C100N	1	10

PART NUMBER	FIG.	ITEM
	7	10
B1821BH031C100N	1	6
	1	10
	2	6
	4	8
B1821BH031C112N	1	8
B1821BH031C113N	4	6
B1821BH031C138N	4	7
B1821BH050C450N	6	22
C-722-3124L	4	10
C-845-2528L	7	11
CL-3A-HK2T	3	6
MS15795-810	1	4
	1	11
MS15795-811	1	17
	4	4
	5	13
	6	5
	6	15
MS15795-812	2	7
MS15795-814	5	25

PART NUMBER	FIG.	ITEM
MS15795-816	6	12
MS15795-818	5	18
	6	25
MS21044C5	5	14
	6	16
	6	21
MS21044C7	6	13
MS24694C152	5	12
	6	14
	6	20
MS27131-51	7	6
MS35338-139	1	3
	1	12
	7	9
MS35338-141	5	24
MS35338-45	1	7
	4	5
	5	6
	6	6
MS51957-80	1	2
S31B200	4	3

---

**CARGO BED COVER (CBC), TYPE III, 2 1/2 T CARGO TRUCK, LMTV, AND LMTV TRAILER 0053 00  
COMPONENTS OF END ITEM (COEI) AND BASIC ISSUE ITEM (BII) LIST**

---

## **INTRODUCTION**

### **Scope**

This section lists COEI and BII for the CBC to help you inventory items for safe and efficient operation of the equipment.

### **General**

The COEI and BII information is divided into the following lists:

1. Components of End Item (COEI). This list is for information purposes only and is not authority to requisition replacements. These items are part of the CBC. As part of the end item, these must be with the end item whenever it is issued or transferred between property accounts. Items of COEI are removed and separately packaged for transportation or shipment only when necessary. Illustrations are furnished to help you find and identify the items.

2. Basic Issue Items (BII). These essential items are required to place the CBC in operation, operate it, and to do emergency repairs. Although shipped separately packaged, BII must be with the CBC during operation and when it is transferred between property accounts. Listing these items is your authority to request / requisition them for replacement based on authorization of the end item by the TOE/MTOE. Illustrations are furnished to help you find and identify the items.

### Explanation of Columns in the COEI List and BII List

Column 1, Illus Number, gives you the number of the item illustrated.

Column 2, National Stock Number, identifies the stock number of the item to be used for requisitioning purposes.

Column 3, Description, CAGEC, and Part Number, identifies the Federal item name (in all capital letters) followed by a minimum description when needed. The last line below the description is the CAGEC (commercial and Government entity code) (in parenthesis) and the part number.

Column 4, Usable on code, gives you a code if the item you need is not the same for different models of equipment.

Column 5, UM (unit of measure), indicates how the item is issued for the National Stock Number shown in column 2.

Column 6, Qty Rqr, indicates the quantity required.

TM 10-5411-233-13&P

**CARGO BED COVER (CBC), TYPE III, 2 1/2 T CARGO TRUCK, LMTV, AND LMTV TRAILER 0053 00  
COMPONENTS OF END ITEM (COEI) AND BASIC ISSUE ITEM (BII) LIST**

**COMPONENTS OF END ITEM (COEI) LIST**

Table 1. Components of End Item List.

(1) ILLUS NUMBER	(2) NATIONAL STOCK NUMBER	(3) DESCRIPTION, LOCATION, PART NUMBER, AND (CAGEC)	(4) USABLE ON CODE	(5) U/M	(6) QTY RQR
		The Cargo Bed Cover (CBC), Type III, 2 1/2 T Cargo Truck, LMTV, and LMTV Trailer has no Components of End Item			

**TM 10-5411-233-13&P**  
**CARGO BED COVER (CBC), TYPE III, 2 1/2 T CARGO TRUCK, LMTV, AND LMTV TRAILER 0053 00**  
**COMPONENTS OF END ITEM (COEI) AND BASIC ISSUE ITEM (BII) LIST**

**BASIC ISSUE ITEMS (BII) LIST**

TM 10-5411-233-13&P

---

TECHNICAL MANUAL

OPERATOR'S, UNIT, AND DIRECT SUPPORT  
 MAINTENANCE MANUAL  
 INCLUDING REPAIR PARTS AND SPECIAL TOOLS LISTS (RPSTL)  
 FOR

**CARGO BED COVER (CBC), TYPE III,  
 2 1/2 T CARGO TRUCK, LMTV, AND  
 LMTV TRAILER**

NSN 5411-01-472-7852 (CAMOUFLAGE)  
 NSN 5411-01-479-1932 (DESERT SAND)



DISTRIBUTION STATEMENT A – Approved for public release; distribution is unlimited.

---

HEADQUARTERS, DEPARTMENT OF THE ARMY

30 September 2002

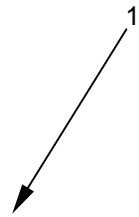

Table 2. Basic Issue Items List

(1) ILLUS NUMBER	(2) NATIONAL STOCK NUMBER	(3) DESCRIPTION, PART NUMBER AND CAGEC	(4) USABLE ON CODE	(5) U/M	(6) QTY RQR
1	N/A	TM 10-5411-233-13&P	FQV	EA	1





---

**CARGO BED COVER (CBC), TYPE III, 2 1/2 T CARGO TRUCK, LMTV, AND LMTV TRAILER 0054 00  
ADDITIONAL AUTHORIZED ITEMS LIST**

---

**SCOPE**

This section lists additional items you are authorized for the support of the CBC.

**GENERAL**

This list identifies items that do not have to accompany the CBC and that do not have to be turned in with it. These items are all authorized to you by CTA, MTOE, TDA, or JTA.

**Explanation of Columns in the AAL**

Column (1) National Stock Number, identifies the stock number of the item to be used for requisitioning purposes.

Column (2) Description, CAGEC, and Part Number, identifies the Federal Item Name (in all capital letters) followed by a minimum description when needed. The last line below the description is the CAGE (Commercial and Government Entity Code) (in parenthesis) and the part number.

Column (3), Usable On Code, when applicable, gives you a code if the item you need is not the same for different models of equipment.

Column (4), UM (unit of measure) indicates how the item is issued for the National Stock Number shown in column (1).

Column (5), Qty Recm, indicates the quantity recommended.

**ADDITIONAL AUTHORIZED LIST ITEMS**

There are no additional authorized items for the Cargo Bed Cover (CBC), Type III, 2 1/2 T Cargo Truck, LMTV, and LMTV Trailer.



**CARGO BED COVER (CBC), TYPE III, 2 1/2 T CARGO TRUCK, LMTV, AND LMTV TRAILER 0055 00  
EXPENDABLE AND DURABLES ITEMS LIST**

**INTRODUCTION**

**Scope**

This section lists expendable and durable items that you will need to operate and maintain the CBC. This list is for information only and is not authority to requisition the listed items. These items are authorized to you by CTA 50-970, Expendable/Durable Items (Except Medical, Class V Repair Parts, and Heraldic Items), or CTA 8-100, Army Medical Department Expendable/Durable Items.

**Explanations of Columns in the Expendable / Durable Items List**

Column (1) Item Number. This number is assigned to the entry in the list and is referenced in the narrative instructions to identify the item (e.g.,=Use lubricating oil (WP0055, Table 1, Item 1).

Column (2) Level. This column includes the lowest level of maintenance that requires the listed item.

- C** Operator or Crew
- O** Unit Maintenance
- F** Direct Support Maintenance
- H** General Support Maintenance
- D** Depot Maintenance

Column (3) National Stock Number. This is the NSN assigned to the item which you can use to requisition it.

Column (4) Item Name, Description, CAGEC, and Part Number. This column provides the other information you need to identify the item.

Column (5), U/M (unit of measure) indicates how the item is issued for the National Stock Number shown in column (1).

**EXPENDABLE AND DURABLE ITEMS LIST**

Table 1. Expendable and Durable Items List

(1) ITEM NUMBER	(2) LEVEL	(3) NATIONAL STOCK NUMBER	(4) ITEM NAME, DESCRIPTION, (CAGEC), PART NUMBER	(5) U/M
1	O, F	9150-00-145--0112	OIL, MACHINE, (58536), A-A-59113	CN
2	O, F		ANTI-SEIZE LUBRICANT, (39428), 1279K31	TB
3	O, F	6810-00-687-8429	SOLVENT, METHYLETHYLKETONE (81346), ASTM D-740	CN
4	O, F		ALUMINUM PLATE	EA
5	O, F	7510-00-015-0447	TAPE, MASKING (1 INCH WIDE), (2J209), 1-3M	RO
6	O, F	7920-00-205-1711	RAGS, WIPING, (58536), A-A-2522	BE
7	O, F		DETERGENT	GL
8	O, F	5350-00-161-9044	SANDPAPER, 100 GRIT, (58536), A-A-1201	PG
9	O, F	8040-01-035-7848	ADHESIVE, TWO PART EPOXY, (92528), FE-6026	KT

**TM 10-5411-233-13&P**

**CARGO BED COVER (CBC), TYPE III, 2 1/2 T CARGO TRUCK, LMTV, AND LMTV TRAILER 0055 00  
EXPENDABLE AND DURABLES ITEMS LIST**

Table 1. Expendable and Durable Items List - continued

(1) ITEM NUMBER	(2) LEVEL	(3) NATIONAL STOCK NUMBER	(4) ITEM NAME, DESCRIPTION, (CAGEC), PART NUMBER	(5) U/M	
10	O, F	5320-00-882-8388	CARTRIDGES, 1/10 GALLON, EMPTY, (39428), 7579A44	PK	
11	O, F		NOZZLE, 2 1/2 IN LONG WITH 1/8 IN ORIFICE, (39428), 7579A32	PK	
12	O, F		ALODINE, BRUSH, (96906), MIL-C-5541	QT	
13	O, F		RIVET,DOME HD (1/8 INCH)), (07707) AD43H	HD	
14	O, F		STICKS, MIXING	EA	
15	O, F		SHEET, ALUMINUM, .032 INCH X 12 INCH X 12 INCH (30003-H16, 5052-H34, OR 6061-T6 ALUMINUM ALLOY)	EA	
16	O, F		CORE, 1.00 INCH THICK X 12 INCHES X 12 INCHES (HEXCEL ACG HONEYCOMB, (04621), ACG-1/2-2.3P	EA	
17	O, F		CORE, 1.50 INCH THICK X 12 INCHES X 12 INCHES (HEXCEL ACG HONEYCOMB, (04621), ACG-1/2-2.3P	EA	
18	O, F		SEALANT, TYPE II, (96906), MIL-S-8802	TB	
19	O, F		GLOVES, WHITE, CLOTH	PK	
20	O, F		8040-00-201-8835	ADHESIVE, (01139), PSA529	QT
21	O, F		8040-00-097-6524	CATALYST, (01139), SRC18	KT
22	O,F			WOOD, 2 x 4 SECTION, 24 INCHES IN LENGTH	EA

**CARGO BED COVER (CBC), TYPE III, 2 1/2 T CARGO TRUCK, LMTV, AND LMTV TRAILER  
ALPHABETICAL INDEX**

**ALPHABETICAL INDEX**

**A**

Abbreviations and Acronyms .....	0001 00
Additional Authorization List (AAL) .....	0046 00
Army Maintenance System MAC .....	0025 00
Assembly And Preparation For Use.....	0005 00

**B**

Basic Issue Items (BI) List.....	0045 00
Bulk Material Repair Parts List.....	0041 00

**C**

Cleaning .....	0010 00
Common Tools And Equipment .....	0002 00
Components Of End Item (COEI) List.....	0045 00
Controls And Indicators.....	0004 00
Corrosion Prevention And Control (CPC) .....	0001 00

**D**

Decals And Instruction Plates .....	0005 00
Description and Use of Operator=s Controls and Indicators .....	0004 00
Destruction Of Army Materiel To Prevent Enemy Use .....	0001 00
Description Of System Components.....	0002 00
Direct Support Maintenance Procedures .....	0023 00

**E**

Environmental Limits on Equipment .....	0002 00
Equipment Characteristics, Capabilities And Features.....	0001 00
Equipment Data .....	0002 00
Equipment Improvements and Recommendations, Reporting (EIR).....	0001 00
Expendable and Durable Items List.....	0047 00
Explanation of Columns in the MAC .....	0025 00
Explanation of Columns in the Tools and Test Equipment Requirements .....	0025 00
Explanation of Columns in Remarks.....	0025 00

**F**

Field Manuals.....	0024 00
Forms .....	0024 00

**CARGO BED COVER (CBC), TYPE III, 2 1/2 T CARGO TRUCK, LMTV, AND LMTV TRAILER  
ALPHABETICAL INDEX**

**G**

General Information..... 0001 00

**H**

How to Locate Repair Parts ..... 0026 00  
How to Use this Manual ..... g

**I**

Introduction To Components Of End Item (COEI) and Basic Issue Items (BII) List ..... 0045 00  
Introduction To Maintenance Allocation Chart ..... 0025 00

**L**

List Of Abbreviations/Acronyms ..... 0001 00  
Location And Description Of Major Components..... 0002 00  
Lubrication Service Intervals ..... 0010 00

**M**

Maintenance Allocation Chart ..... 0025 00  
Maintenance Forms Records And Reports..... 0024 00  
Maintenance Functions ..... 0025 00  
Maintenance, Direct Support..... 0023 00  
Maintenance Procedures, Unit..... 0012 00  
Malfunction Symptom Index..... 0008 00  
Mandatory Replacement Parts ..... 0048 00

**N**

National Stock Number Index ..... 0042 00  
Nomenclature Cross-Reference List..... 0001 00

**O**

Operations under Usual Conditions ..... 0005 00  
Operation In Unusual Environment/Weather Conditions ..... 0006 00  
Operating Procedures ..... 0005 00  
Operator Services ..... 0010 00

**P**

Pamphlets ..... 0024 00  
Part Number Index ..... 0044 00

**CARGO BED COVER (CBC), TYPE III, 2 1/2 T CARGO TRUCK, LMTV, AND LMTV TRAILER  
ALPHABETICAL INDEX**

Preparation For Movement .....	0005 00
Preparing CBC and Associated Equipment For Storage .....	0005 00
Preventive Maintenance Checks And Services (PMCS) .....	0010 00

**Q**

Quality Deficiency Report .....	0024 00
---------------------------------	---------

**R**

References .....	0024 00
Remarks For CBC .....	0025 00
Repair Parts and Special Tools List .....	0026 00
Reporting Equipment Improvement Recommendations (EIRs) .....	0001 00
Reporting Errors and Recommending Improvements .....	0024 00

**S**

Safety, Care And Handling, Warnings, Cautions And Notes .....	0001 00
Service upon Receipt .....	0012 00
Siting Requirements .....	0012 00
Special Tools List .....	0043 00

**T**

Table of Contents .....	c
Technical Manuals .....	0024 00
Theory Of Operation .....	0003 00
Tools And Test Equipment Requirements .....	0025 00
Troubleshooting Procedures .....	0009 00

**U**

Unit Maintenance Procedures .....	0018 00
Unpacking .....	0018 00
Usable On Code .....	0026 00

**V**

**W**

Warnings .....	a
----------------	---





By Order of the Secretary of the Army:

Official:



JOEL B. HUDSON

*Administrative Assistant to the  
Secretary of the Army*

0220303

ERIC K. SHINSEKI  
*General, United States Army  
Chief of Staff*

DISTRIBUTION:

To be distributed in accordance with initial distribution IDN 256681, requirements for TM 10-5411-233-13&P.



## ***These are the instructions for sending an electronic 2028***

The following format must be used if submitting an electronic 2028. The subject line must be exactly the same and all fields must be included; however only the following fields are mandatory: 1, 3, 4, 5, 6, 7, 8, 9, 10, 13, 15, 16, 17, and 27.

From: "Whomever" <whomever@avma27.army.mil>

To: amssbriml@natick.army.mil

Subject: DA Form 2028

1. **From:** Joe Smith
2. **Unit:** home
3. **Address:** 4300 Park
4. **City:** Hometown
5. **St:** MO
6. **Zip:** 77777
7. **Date Sent:** 19-OCT-93
8. **Pub no:** 55-2840-229-23
9. **Pub Title:** TM
10. **Publication Date:** 04-JUL-85
11. **Change Number:** 7
12. **Submitter Rank:** MSG
13. **Submitter FName:** Joe
14. **Submitter MName:** T
15. **Submitter LName:** Smith
16. **Submitter Phone:** 123-123-1234
17. **Problem:** 1
18. **Page:** 2
19. **Paragraph:** 3
20. **Line:** 4
21. **NSN:** 5
22. **Reference:** 6
23. **Figure:** 7
24. **Table:** 8
25. **Item:** 9
26. **Total:** 123
27. **Text:**

This is the text for the problem below line 27.



<b>RECOMMENDED CHANGES TO PUBLICATIONS AND BLANK FORMS</b> For use of this form, see AR 25-30; the proponent agency is ODISC4.						Use Part II ( <i>reverse</i> ) for Repair Parts and Special Tool Lists (RPSTL) and Supply Catalogs/Supply Manuals (SC/SM).	<b>DATE</b> 21 October 2003
<b>TO:</b> ( <i>Forward to proponent of publication or form</i> ) ( <i>Include ZIP Code</i> ) COMMANDER U.S. ARMY TANK-AUTOMOTIVE AND ARMAMENT COMMAND ATTN: AMSTA-LC-CECT 15 KANSAS STREET NATICK, MA 01760-5052						<b>FROM:</b> ( <i>Activity and location</i> ) ( <i>Include ZIP Code</i> )  <i>PFC Jane Doe</i> <i>CO A 3<sup>rd</sup> Engineer BR</i> <i>Ft. Leonardwood, MO 63108</i>	
<b>PART I – ALL PUBLICATIONS (EXCEPT RPSTL AND SC/SM) AND BLANK FORMS</b>							
<b>PUBLICATION/FORM NUMBER</b>  TM 10-1670-296-23&P				<b>DATE</b>  30 October 2002	<b>TITLE</b>  Unit Manual for Ancillary Equipment for Low Velocity Air Drop Systems		
<b>ITEM NO.</b>	<b>PAGE NO.</b>	<b>PARA-GRAPH</b>	<b>LINE NO. *</b>	<b>FIGURE NO.</b>	<b>TABLE NO.</b>	<b>RECOMMENDED CHANGES AND REASON</b> <i>(Provide exact wording of recommended changes, if possible).</i>	
	0036 00-2				1	<i>In table 1, Sewing Machine Code Symbols, the second sewing machine code symbol should be MD ZZ not MD 22.</i>  <i>Change the manual to show Sewing Machine, Industrial: Zig-Zag; 308 stitch; medium-duty; NSN 3530-01-181-1421 as a MD ZZ code symbol.</i>	
<i>*Reference to line numbers within the paragraph or subparagraph.</i>							
<b>TYPED NAME, GRADE OR TITLE</b>  Jane Doe, PFC				<b>TELEPHONE EXCHANGE/AUTOVON, PLUS EXTENSION</b>  508-233-4141		<b>SIGNATURE</b>  Jane Doe <i>Jane Doe</i>	

<b>TO:</b> <i>(Forward direct to addressee listed in publication)</i> COMMANDER U.S. ARMY TANK-AUTOMOTIVE AND ARMAMENT COMMAND ATTN: AMSTA-LC-CECT 15 KANSAS STREET NATICK, MA 01760-5052	<b>FROM:</b> <i>(Activity and location) (Include ZIP Code)</i> <i>PFC Jane Doe</i> <i>CO A 3<sup>rd</sup> Engineer BR</i> <i>Ft. Leonardwood, MO 63108</i>	<b>DATE</b> 21 October 2003
--	---	--------------------------------

**PART II – REPAIR PARTS AND SPECIAL TOOL LISTS AND SUPPLY CATALOGS/SUPPLY MANUALS**

<b>PUBLICATION NUMBER</b> TM 10-1670-296-23&P	<b>DATE</b> 30 October 2002	<b>TITLE</b> Unit Manual for Ancillary Equipment for Low Velocity Air Drop Systems
--	--------------------------------	---

PAGE NO.	COLM NO.	LINE NO.	NATIONAL STOCK NUMBER	REFERENCE NO.	FIGURE NO.	ITEM NO.	TOTAL NO. OF MAJOR ITEMS SUPPORTED	RECOMMENDED ACTION
0066 00-1					4			<i>Callout 16 in figure 4 is pointed to a <u>D-Ring</u>. In the Repair Parts List key for figure 4, item 16 is called a <u>Snap Hook</u>. Please correct one or the other.</i>

SAMPLE

**PART III – REMARKS** *(Any general remarks or recommendations, or suggestions for improvement of publications and blank forms. Additional blank sheets may be used if more space is needed.)*

TYPED NAME, GRADE OR TITLE	TELEPHONE EXCHANGE/AUTOVON, PLUS EXTENSION	SIGNATURE
----------------------------	--	-----------

<p align="center"><b>RECOMMENDED CHANGES TO PUBLICATIONS AND BLANK FORMS</b></p> <p>For use of this form, see AR 25-30; the proponent agency is ODISC4.</p>						Use Part II ( <i>reverse</i> ) for Repair Parts and Special Tool Lists (RPSTL) and Supply Catalogs/Supply Manuals (SC/SM).	DATE
TO: ( <i>Forward to proponent of publication or form</i> ) ( <i>Include ZIP Code</i> ) COMMANDER U.S. ARMY TANK-AUTOMOTIVE AND ARMAMENT COMMAND ATTN: AMSTA-LC-CECT 15 KANSAS STREET NATICK, MA 01760-5052						FROM: ( <i>Activity and location</i> ) ( <i>Include ZIP Code</i> )	
<b>PART I - ALL PUBLICATIONS (EXCEPT RPSTL AND SC/SM) AND BLANK FORMS</b>							
PUBLICATION/FORM NUMBER TM 10-5411-233-13&P						DATE 30 September 2002	TITLE Operator's, Unit, and Direct Support Maintenance Manual, Including Repair Parts and Special Tools List (RPSTL), for Cargo Bed Cover (CBC), Type III
ITEM NO.	PAGE NO.	PARA-GRAPH	LINE NO. *	FIGURE NO.	TABLE NO.	RECOMMENDED CHANGES AND REASON <i>(Provide exact wording of recommended changes, if possible).</i>	
<i>*Reference to line numbers within the paragraph or subparagraph.</i>							
TYPED NAME, GRADE OR TITLE				TELEPHONE EXCHANGE/AUTOVON, PLUS EXTENSION		SIGNATURE	

TO: <i>(Forward direct to addressee listed in publication)</i> COMMANDER U.S. ARMY TANK-AUTOMOTIVE AND ARMAMENT COMMAND ATTN: AMSTA-LC-CECT 15 KANSAS STREET NATICK, MA 01760-5052	FROM: <i>(Activity and location) (Include ZIP Code)</i>	DATE
---	---	------

**PART II – REPAIR PARTS AND SPECIAL TOOL LISTS AND SUPPLY CATALOGS/SUPPLY MANUALS**

PUBLICATION NUMBER TM 10-5411-233-13&P	DATE 30 September 2002	TITLE Operator's, Unit, and Direct Support Maintenance Manual, Including Repair Parts and Special Tools List (RPSTL), for Cargo Bed Cover (CBC), Type III
---	---------------------------	--

PAGE NO.	COLM NO.	LINE NO.	NATIONAL STOCK NUMBER	REFERENCE NO.	FIGURE NO.	ITEM NO.	TOTAL NO. OF MAJOR ITEMS SUPPORTED	RECOMMENDED ACTION

**PART III – REMARKS** *(Any general remarks or recommendations, or suggestions for improvement of publications and blank forms. Additional blank sheets may be used if more space is needed.)*

TYPED NAME, GRADE OR TITLE	TELEPHONE EXCHANGE/AUTOVON, PLUS EXTENSION	SIGNATURE
----------------------------	--	-----------



<p align="center"><b>RECOMMENDED CHANGES TO PUBLICATIONS AND BLANK FORMS</b></p> <p>For use of this form, see AR 25-30; the proponent agency is ODISC4.</p>						Use Part II ( <i>reverse</i> ) for Repair Parts and Special Tool Lists (RPSTL) and Supply Catalogs/Supply Manuals (SC/SM).	DATE
TO: ( <i>Forward to proponent of publication or form</i> ) ( <i>Include ZIP Code</i> ) COMMANDER U.S. ARMY TANK-AUTOMOTIVE AND ARMAMENT COMMAND ATTN: AMSTA-LC-CECT 15 KANSAS STREET NATICK, MA 01760-5052						FROM: ( <i>Activity and location</i> ) ( <i>Include ZIP Code</i> )	
<b>PART I - ALL PUBLICATIONS (EXCEPT RPSTL AND SC/SM) AND BLANK FORMS</b>							
PUBLICATION/FORM NUMBER TM 10-5411-233-13&P				DATE 30 September 2002	TITLE Operator's, Unit, and Direct Support Maintenance Manual, Including Repair Parts and Special Tools List (RPSTL), for Cargo Bed Cover (CBC), Type III		
ITEM NO.	PAGE NO.	PARA-GRAPH	LINE NO. *	FIGURE NO.	TABLE NO.	RECOMMENDED CHANGES AND REASON <i>(Provide exact wording of recommended changes, if possible).</i>	
<i>*Reference to line numbers within the paragraph or subparagraph.</i>							
TYPED NAME, GRADE OR TITLE				TELEPHONE EXCHANGE/AUTOVON, PLUS EXTENSION		SIGNATURE	

TO: <i>(Forward direct to addressee listed in publication)</i> COMMANDER U.S. ARMY TANK-AUTOMOTIVE AND ARMAMENT COMMAND ATTN: AMSTA-LC-CECT 15 KANSAS STREET NATICK, MA 01760-5052	FROM: <i>(Activity and location) (Include ZIP Code)</i>	DATE
---	---	------

**PART II – REPAIR PARTS AND SPECIAL TOOL LISTS AND SUPPLY CATALOGS/SUPPLY MANUALS**

PUBLICATION NUMBER TM 10-5411-233-13&P	DATE 30 September 2002	TITLE Operator's, Unit, and Direct Support Maintenance Manual, Including Repair Parts and Special Tools List (RPSTL), for Cargo Bed Cover (CBC), Type III
---	---------------------------	--

PAGE NO.	COLM NO.	LINE NO.	NATIONAL STOCK NUMBER	REFERENCE NO.	FIGURE NO.	ITEM NO.	TOTAL NO. OF MAJOR ITEMS SUPPORTED	RECOMMENDED ACTION

**PART III – REMARKS** *(Any general remarks or recommendations, or suggestions for improvement of publications and blank forms. Additional blank sheets may be used if more space is needed.)*

TYPED NAME, GRADE OR TITLE	TELEPHONE EXCHANGE/AUTOVON, PLUS EXTENSION	SIGNATURE
----------------------------	--	-----------

## The Metric System and Equivalents

### *Linear Measure*

1 centimeter = 10 millimeters = .39 inch  
 1 decimeter = 10 centimeters = 3.94 inches  
 1 meter = 10 decimeters = 39.37 inches  
 1 dekameter = 10 meters = 32.8 feet  
 1 hectometer = 10 dekameters = 328.08 feet  
 1 kilometer = 10 hectometers = 3,280.8 feet

### *Weights*

1 centigram = 10 milligrams = .15 grain  
 1 decigram = 10 centigrams = 1.54 grains  
 1 gram = 10 decigrams = .035 ounce  
 1 dekagram = 10 grams = .35 ounce  
 1 hectogram = 10 dekagrams = 3.52 ounces  
 1 kilogram = 10 hectograms = 2.2 pounds  
 1 quintal = 100 kilograms = 220.46 pounds  
 1 metric ton = 10 quintals = 1.1 short tons

### *Liquid Measure*

1 centiliter = 10 milliliters = .34 fl. ounce  
 1 deciliter = 10 centiliters = 3.38 fl. ounces  
 1 liter = 10 deciliters = 33.81 fl. ounces  
 1 dekaliter = 10 liters = 2.64 gallons  
 1 hectoliter = 10 dekaliters = 26.42 gallons  
 1 kiloliter = 10 hectoliters = 264.18 gallons

### *Square Measure*

1 sq. centimeter = 100 sq. millimeters = .155 sq. inch  
 1 sq. decimeter = 100 sq. centimeters = 15.5 sq. inches  
 1 sq. meter (centare) = 100 sq. decimeters = 10.76 sq. feet  
 1 sq. dekameter (are) = 100 sq. meters = 1,076.4 sq. feet  
 1 sq. hectometer (hectare) = 100 sq. dekameters = 2.47 acres  
 1 sq. kilometer = 100 sq. hectometers = .386 sq. mile

### *Cubic Measure*

1 cu. centimeter = 1000 cu. millimeters = .06 cu. inch  
 1 cu. decimeter = 1000 cu. centimeters = 61.02 cu. inches  
 1 cu. meter = 1000 cu. decimeters = 35.31 feet

## Approximate Conversion Factors

<i>To change</i>	<i>To</i>	<i>Multiply by</i>	<i>To change</i>	<i>To</i>	<i>Multiply by</i>
inches	centimeters	2.540	ounce-inches	newton-meters	.007062
feet	meters	.305	centimeters	inches	.394
yards	meters	.914	meters	feet	3.280
miles	kilometers	1.609	meters	yards	1.094
square inches	square centimeters	6.451	kilometers	miles	.621
square feet	square meters	.093	square centimeters	square inches	.155
square yards	square meters	.836	square meters	square feet	10.764
square miles	square kilometers	2.590	square meters	square yards	1.196
acres	square hectometers	.405	square kilometers	square miles	.386
cubic feet	cubic meters	.028	square hectometers	acres	2.471
cubic yards	cubic meters	.765	cubic meters	cubic feet	35.315
fluid ounces	milliliters	29.573	cubic meters	cubic yards	1.308
pints	liters	.473	milliliters	fluid ounces	.034
quarts	liters	.946	liters	pints	2.113
gallons	liters	3.785	liters	quarts	1.057
ounces	grams	28.349	liters	gallons	.264
pounds	kilograms	.454	grams	ounces	.035
short tons	metric tons	.907	kilograms	pounds	2.205
pound-feet	newton-meters	1.356	metric tons	short tons	1.102
pound-inches	newton-meters	.11296			

## Temperature (Exact)

_F	Fahrenheit temperature	5/9 (after subtracting 32)	Celsius temperature	_C
----	---------------------------	-------------------------------	------------------------	----

**PIN: 080103-000**